

A GENERAL METHOD OF FEEDBACK AMPLIFIER ANALYSIS

Borivoje Nikolić

Department of Electrical and Computer Engineering
University of California
Davis, CA 95616, USA

Slavoljub Marjanović

Faculty of Electrical Engineering
University of Belgrade
Belgrade, Yugoslavia

ABSTRACT

A new method of feedback amplifier analysis is presented. The existing approaches to analysis and design of feedback amplifiers are either based on modeling of two-port amplifier and feedback networks or on calculating the return-ratio. These two approaches produce different results for the loop gain and return-ratio, and depending on circuit topology, can significantly differ in resulting closed loop gain. The new approach is based on the calculation of the return-ratio and the exact modeling of the amplifier without feedback. Resulting expressions for the loop gain and the return ratio are equivalent. The method is algorithmic and gives the exact result for the closed-loop gain. Its application is general, straightforward, allows simple approximations and is suitable for hand analysis as well as for the computer-aided symbolic or numeric analysis. The method is verified on typical examples of negative feedback amplifiers.

1. INTRODUCTION

In the design of feedback amplifiers it is very important to accurately model the amplifier behavior. The design of the amplifier with the negative feedback usually involves the preliminary hand analysis and paper design, which precedes building of the prototype. In the process of analysis by hand it is extremely important to separate the influence of circuit elements on the amplifier characteristics, such as overall gain, return ratio, frequency response, input and output impedance. It is also very helpful in the analysis to easily make necessary approximations in order to obtain the simple analytical expressions.

Analysis of the feedback circuits is usually complicated by the interaction of the amplifier feedback circuit. The theory of analysis and design of feedback circuits was presented in many papers and textbooks [1-15]. It is usually based on modeling the internal amplifier and feedback networks by two-ports. It was tried to separate the gain of the amplifier without feedback, a , reverse transmission (feedback) factor, f , and from this results to calculate the loop gain, af , and the closed-loop gain of the amplifier with feedback.

The other approach to feedback amplifier analysis [1,2] is based on determining the return-ratio, as it was originally defined by Bode [3], and relating it to the closed-loop amplifier gain, by using the asymptotic gain formula.

It was noted that two-port analysis of these networks led to different results for the loop gain and the return ratio. Even though the results for these two properties can be significantly different [4,5], they are usually considered to be the same in many textbooks [8,9].

The approach proposed in this paper exactly models the amplifier without feedback, calculates the return ratio and from these equations calculates the closed-loop gain. This allows additional degrees of freedom in the design of feedback systems, comparing to the asymptotic gain formula [1,2]. In addition, proper modeling of amplifier loading by the feedback circuit shows that in this approach the return ratio is equal to the loop gain.

The method presented here is general. This method is exact, but allows simple and straightforward approximations to simplify the results, so it is design oriented. Its application does not require the initial classification of the feedback amplifier topology. The analysis of every amplifier can be reduced to the analysis of the amplifier of the amplifier with the voltage (shunt) feedback, thus eliminating the need for the classification of the circuit topology.

The approach proposed in this paper is also based on the calculation of the return ratio. But, as opposed to the asymptotic gain formula, the calculation of the overall gain is based on the modeling of the amplifier with feedback. The amplifier without feedback is separated from the network with feedback network loading included.

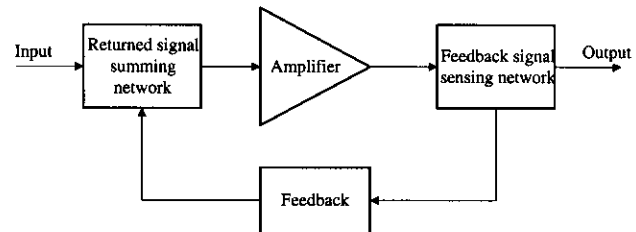

Figure 1. Ideal block diagram of the feedback system

2. BACKGROUND

The general amplifier with negative feedback is represented by the block diagram shown on Fig. 1.

The returned signal summing network and feedback signal sensing network usually can be seen just as a parallel or serial connection of the amplifier and feedback blocks. Traditionally they determine the classification of the feedback as a series or shunt, resulting in the four possible combinations for the amplifier topologies, based on the connection of the amplifier, feedback network, signal source and the load: shunt-shunt, series-shunt, series-series, shunt-series.

In the following analysis we will assume that the amplifier network is strictly unilateral, while the feedback network is bilateral.

Return ratio

The return ratio for a selected controlled source is determined by: 1) determining the direction of the signal flow in the circuit, 2) setting all independent sources to zero, 3) breaking the connection between the source and the rest of the circuit, 4) driving the circuit at the break with an independent voltage (or current) signal source, with the other end of the break closed by the equivalent impedance "seen" at the point of break. 5) the return ratio is then found by finding the ratio of the signal measured at the equivalent impedance to the input signal. To be exact, this approach requires the controlled source to be unilateral. The return ratio would be determined differently if the forward amplifier has significant reverse transmission factor [14,15].

However, the loop gain, defined as product of a and f , as explained above, in many cases differs from the return ratio [4,5].

3. ANALYSIS METHOD

The feedback amplifier can be modeled by the following block diagram [5]:

$$\begin{aligned} V_o &= AV_i + BX_b \\ X_a &= CV_i + DX_b \end{aligned} \quad (1)$$

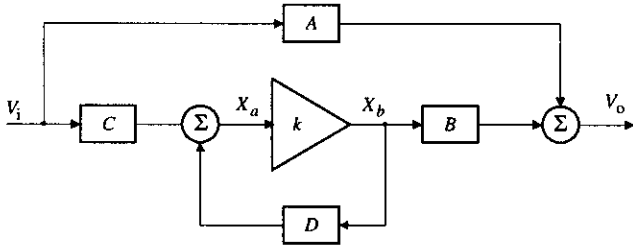

Figure 2. Feedback amplifier block diagram

By solving this system, the gain of the amplifier can be found:

$$G_f = \frac{V_o}{V_i} = \frac{k(BC - AD) + A}{1 - kD} \quad (2)$$

In [1,2] this gain has been interpreted as the asymptotic gain formula:

$$G_f = \frac{KT}{1+T} + \frac{G_0}{1+T} \quad (3)$$

The term KT is here given a different interpretation that adds the new value to the analysis. The formula can be written as:

$$G_f = \frac{G_{ekv}}{1+T} + \frac{G_0}{1+T} \quad (4)$$

where G_{ekv} is the gain of the equivalent amplifier without feedback:

$$G_{ekv} = \left. \frac{X_a}{V_i} \right|_{V_o=0} \cdot \frac{X_b}{X_a} \cdot \left. \frac{V_o}{X_b} \right|_{V_i=0} \quad (5)$$

$$\left. \frac{X_a}{V_i} \right|_{V_o=0} = C - \frac{AD}{B}; \quad \frac{X_b}{X_a} = k; \quad \left. \frac{V_o}{X_b} \right|_{V_i=0} = B \quad (6)$$

This means that the equivalent amplifier is formed by breaking the feedback loop in the way that input circuit of the amplifier is formed by shorting the output and output circuit is formed by switching off the input source. The amplifier loading by the feedback network is included. This approach gives the exact result, as opposed to the method [8], which proposes shorting out the inputs of the amplifier, thus resulting in approximate result.

By application of this equivalence the return ratio is equivalent to the product of G_{ekv} and feedback factor.

In addition to this approach, the calculation of $1/f$ can be done, as shown by [1,2]. The asymptotic gain of the amplifier, K , which corresponds to the case $T \rightarrow \infty$, can be found from the equations (1,2). Then the formula (4) can be viewed as:

$$G_f = K \frac{T}{1+T} + \frac{G_0}{1+T} \quad (7)$$

where the factor K is equal to

$$K = A - \frac{BC}{D} \quad (8)$$

The asymptotic gain corresponds to the case when the gain of the forward amplifier is infinite, and the overall gain is determined by the passive network, i.e. $K = 1/f$. It can be verified that $T = G_{ekv} / K$.

4. EXAMPLES OF APPLICATION

4.1 The inverting amplifier

The inverting amplifier is an example of the feedback amplifier with shunt-shunt connection, as shown on Fig.3.a. The forward amplifier is modeled as voltage controlled voltage source with finite input and output resistance, as shown on Fig.3.b.

The equivalent amplifier without feedback is shown on Fig.3.c. Its input network is formed by short connecting the amplifier outputs, which gives only the resistor R_f while the output network is obtained by switching of the signal source, forming the series connection of R_f and R_s .

The return ratio of the amplifier is equal to its loop gain:

$$T = a \frac{R_s \parallel R_{in}}{R_{out} + R_f + R_s \parallel R_{in}} \quad (9)$$

The gain of the amplifier without feedback is found from Fig. 3.c.

$$G_{ekv} = \frac{R_f \parallel R_{in}}{R_s + R_f \parallel R_{in}} (-a) \frac{R_f + R_s \parallel R_{in}}{R_{out} + R_f + R_s \parallel R_{in}} \quad (10)$$

The direct transmission term is obtained by setting $a = 0$ in the Fig. 3.b:

$$G_0 = \frac{R_{out}}{R_s} \frac{R_s \parallel R_{in}}{R_s \parallel R_{in} + R_f + R_{out}} \quad (11)$$

Combining of these terms in the gain formula gives the exact gain, that can be verified by the use of Kirchoff's laws.

$$G_f = \frac{-(aR_f - R_{out})R_{in}}{(a+1)R_{in}R_s + (R_f + R_{out})(R_{in} + R_s)} \quad (12)$$

It also should be noted that $f = 1/K = -R_s/R_f$ multiplied by G_{ekv} gives the exact expression for the return-ratio.

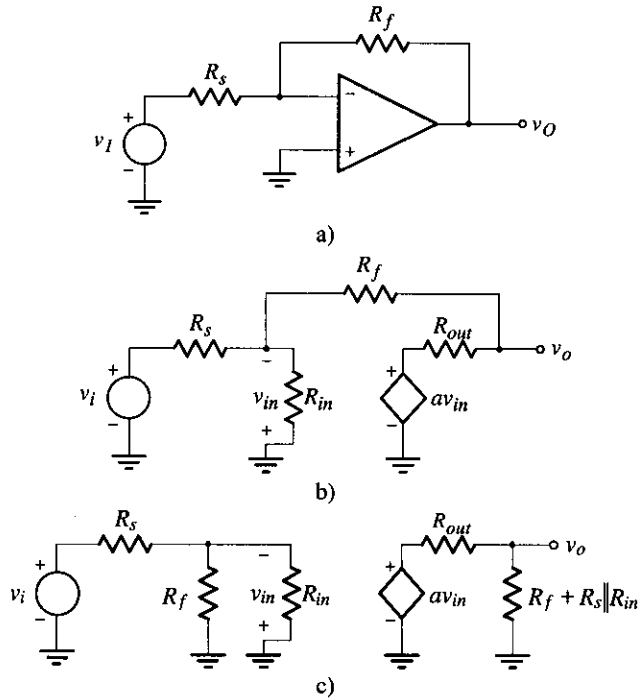

Figure 3. Inverting amplifier: a) schematic, b) equivalent circuit with finite input and output resistances of the opamp, c) equivalent amplifier model.

4.2. Emitter follower

The emitter follower is an example of the amplifier with series shunt feedback. The output voltage is directly from the output node returned in series to the input, resulting in unity-gain feedback.

The return ratio and the equivalent amplifier gain are equal to:

$$T = g_m (r_\pi \parallel R_E) \quad (13)$$

$$G_{ekv} = g_m (r_\pi \parallel R_E) \quad (14)$$

The direct transmission term is obtained by setting $g_m = 0$:

$$G_0 = \frac{R_E}{r_\pi + R_E} \quad (15)$$

The overall amplifier gain is exactly the same as obtained by Kirchoff's laws.

$$G_f = \frac{(1 + \beta_0)R_E}{r_\pi + (1 + \beta_0)R_E} \quad (16)$$

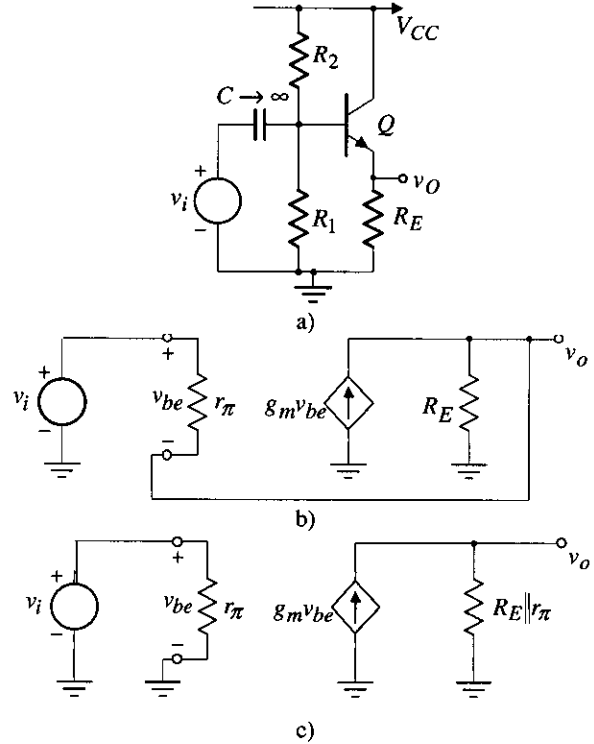

Figure 4. Emitter follower: a) schematic, b) small-signal model with transistor replaced with its hybrid- π equivalent, drawn to illustrate unity gain feedback, c) equivalent amplifier without feedback.

4.3. Common emitter with emitter degeneration

Common emitter amplifier with emitter degeneration is a feedback amplifier with series-series connection, as shown in Fig. 5. Output current is sensed by the emitter resistor and fed back in series to the input.

The return ratio is the same as in the case of emitter follower:

$$T = g_m (r_\pi \parallel R_E) \quad (17)$$

The gain of the amplifier can be derived from the emitter follower case, by notifying that signal X_b from Fig. 2 is equivalent to the emitter voltage. Then the output voltage can be found by replacing the gain of the block B with the transfer function from the emitter to the output:

$$B = -\frac{\beta_0 R_C}{\beta_0 + 1 R_E} \quad (18)$$

This example shows how the current (series) feedback can be reduced to voltage (shunt) feedback. This generalizes the analysis to solving only voltage feedback.

However, the circuit can also be solved traditionally, by assigning X_b to emitter current i_e . The equivalent amplifier gain, from Fig. 5.c:

$$G_{ekv} = \frac{r_\pi}{r_\pi + R_E} (-g_m R_C) \quad (19)$$

There is no transmission of the signal from the input to the output with $g_m = 0$, and $G_0 = 0$.

$$G_f = \frac{-\beta_0 R_C}{r_\pi + (1 + \beta_0) R_E} \quad (20)$$

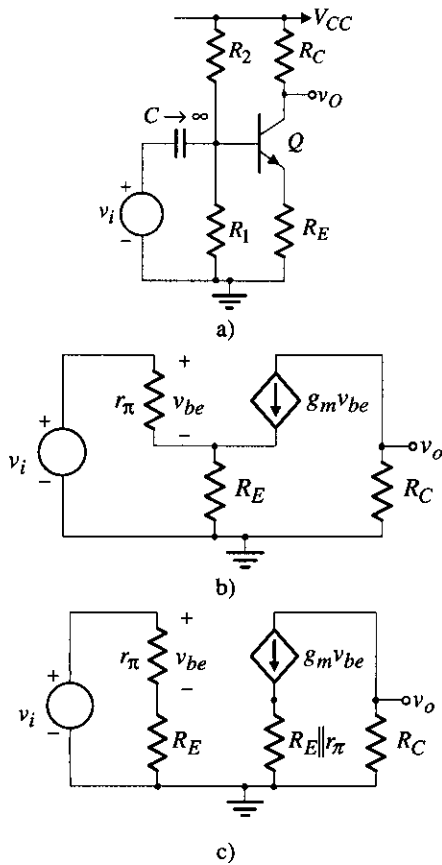

Figure 5. Common emitter with emitter degeneration: a) schematic, b) small-signal model, c) equivalent amplifier without feedback.

5. CONCLUSION

The method of analyzing amplifiers with negative feedback is presented in this paper. It is based on calculation of the return ratio of the feedback amplifier and exact modeling of the amplifier without feedback. As opposed to other methods, this approach is characterized by the equivalence between the return ratio and loop gain.

The importance of the method is that amplifier without feedback and the feedback network can be designed and analyzed

independently. This gives the additional information about the feedback amplifier and new designable parameters. It allows approximations to simplify the design. The method is illustrated by hand analysis of common feedback circuits, but can be implemented in numeric or symbolic computer-aided design programs.

6. REFERENCES

- [1] S. Rosenstark, "A Simplified Method of Feedback Amplifier Analysis" *IEEE Trans. on Education*, vol. E-17, No. 4, pp. 192 - 198, nov. 1974.
- [2] S. Rosenstark, *Feedback Amplifier Principles*. New York, NY: MacMillan, 1986.
- [3] H.W. Bode, *Network Analysis and Feedback Amplifier Design*. New York, NY: Van Nostrand, 1945.
- [4] P.J. Hurst, "Exact Simulation of Feedback Circuit Parameters", *IEEE Trans. on CAS*, vol 38, no 11, pp. 1382 - 1389, Nov. 1991.
- [5] P.J. Hurst, "A Comparison of Two Approaches to Feedback Circuit Analysis," *IEEE Trans. on Education*," vol. 35, no. 3, pp. 253-261, Aug. 1992.
- [6] F. Waldhauer, *Feedback*. New York, NY: Wiley, 1982.
- [7] S.S. Hakim, *Feedback Circuit Analysis*, New York, NY: Wiley, 1966.
- [8] P.R. Gray, R.G. Meyer, *Analysis and Design of Analog Integrated Circuits*, 3rd ed. New York, NY: Wiley, 1993.
- [9] J. Millman, A. Grabel, *Microelectronics*, 2nd ed. New York, NY: McGraw-Hill, 1988.
- [10] C. Belove, D.L.Schilling, "Feedback Made Easy for the Undergraduate", *IEEE Trans. on Education*, vol E-12, no.2, pp. 97 - 103, June 1969.
- [11] A.M. Davis, "A General Method for Analyzing Feedback Amplifiers", *IEEE Trans. on Education*, vol E-24, no.4, pp. 291 - 293, November 1981.
- [12] K.S. Yeung, "An Alternative Approach for Analyzing Feedback Amplifiers", *IEEE Trans. on Education*, vol E-25, no.4, pp. 132 - 136, November 1982.
- [13] S. Ben-Yaakov, "A Unified Approach to Teaching Feedback in Electronic Circuits Courses", *IEEE Trans. on Education*, vol 34, no.4, pp. 310 - 316, Nov. 1991.
- [14] R.D. Middlebrook, "Measurement of Loop Gain in Feedback Systems," *Int. J. on Electronics*, vol. 38, no. 4, pp. 485-512, Apr. 1975.
- [15] S. Rosenstark, "Loop Gain Measurement in Feedback Amplifiers," *Int. J. on Electronics*, vol. 57, no.3, pp 415-421, Mar.1984.