Design and Analysis of Micro-Solar Power Systems for Wireless Sensor Networks

Jaein Jeong
UC Berkeley, Computer Science

with

Xiaofan Jiang and David Culler

Solar Energy Harvesting for WSN

- Energy harvesting is needed for large-scale long-term deployment.
- Several designs made for different requirements, but little analysis is done for an ultimate design.



Our Contributions

- Model for micro-solar power system.
- Empirical and mathematical analysis on two leading designs (Heliomote and Trio).
- Propose a design guideline for micro-solar power systems.

Organization

- System Architecture
- Model for Each Component
 - Load: Sensor Node
 - External Environment
 - Solar Collector
 - Energy Storage
- Comparative Study
 - Solar-Collector Operation
 - Energy flow and Energy efficiency
- Conclusion

System Architecture

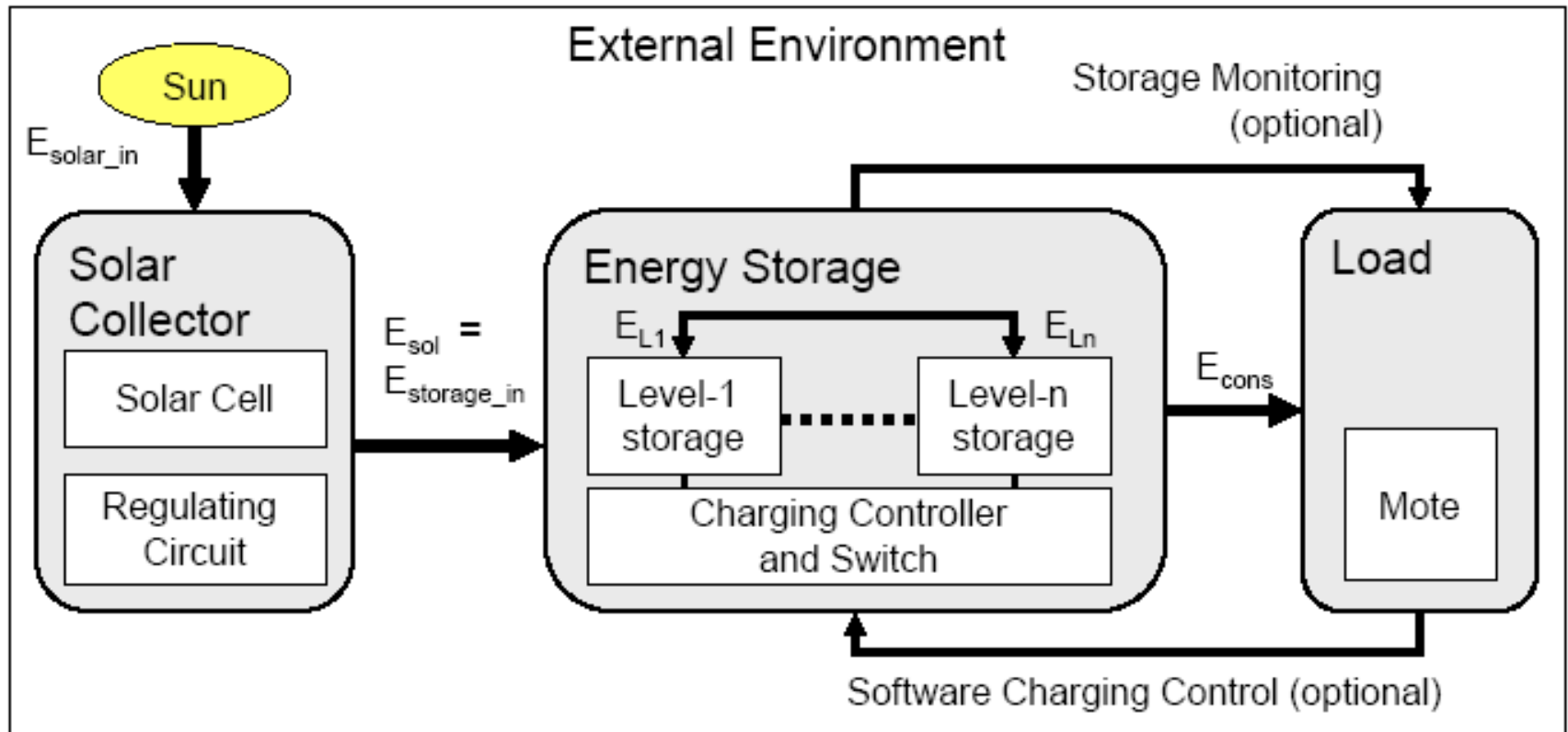

- Evaluation Metrics

- $Eff_{solar} = P_{on} / P_{maxP}$

- $Eff_{system} = (E_{L1} + \dots + E_{Ln} + E_{cons}) / E_{sol}$

Load (Sensor Node): Estimating Node Consumption

- Energy consumption with radio comm:
 - $I_{est} = R * I_{awake} + (1-R) * I_{sleep}$

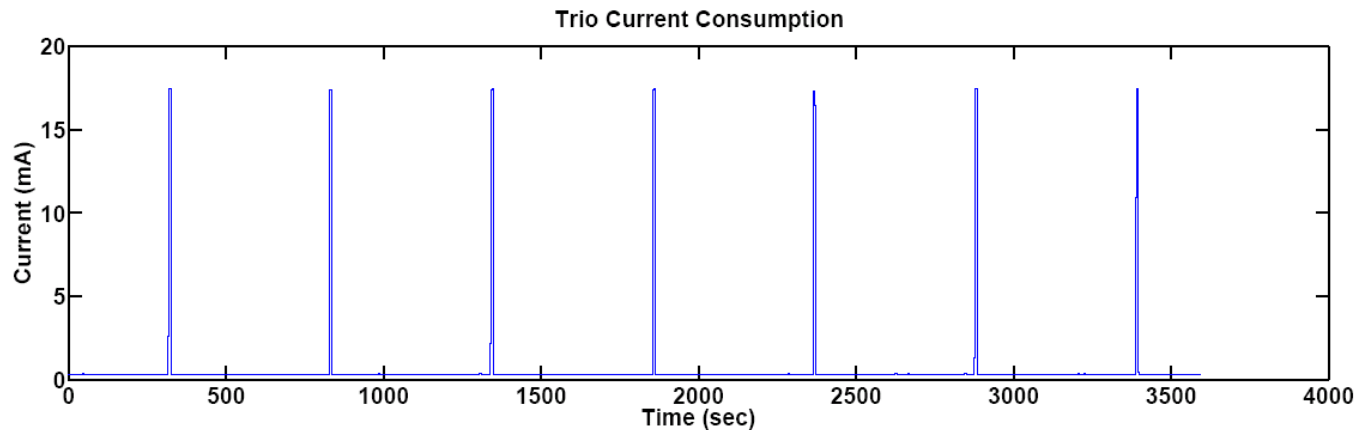

	1.56%	6.25%	12.5%	25%	50%
I_{avg} (mA)	0.5276	1.327	2.4082	4.5685	8.8537
I_{sleep} (mA)	0.2638	0.2646	0.2764	0.2745	0.3192
I_{awake} (mA)	17.4138	17.3417	17.3546	17.3055	17.3618
I_{est} (mA)	0.5363	1.3376	2.4053	4.5408	8.8119
Deviation $\frac{I_{avg} - I_{est}}{I_{est}}$	-1.62%	-0.79%	0.12%	0.61%	0.47%

External Environment: Estimating Solar Radiation

- Statistical Model

	Jan	Feb	Mar	Apr	May	Jun	
E_{month}	67	83	132	170	208	215	
PSH	2.16	2.96	4.26	5.67	6.71	7.17	
	Jul	Aug	Sep	Oct	Nov	Dec	Year
E_{month}	228	202	161	121	75	61	1718
PSH	7.35	6.52	5.37	3.90	2.50	1.97	4.71

$$E_{solar_in} = \frac{E_{month}}{\#days}$$

$$PSH = \frac{E_{solar_in}}{1kW/m^2}$$

$$E_{sol} = PSH \cdot P_{solar}$$

- Mathematical Model

Solar-cell current measurement for Trio node and cosine of solar inclination estimation in Berkeley, CA on 10/10/2006

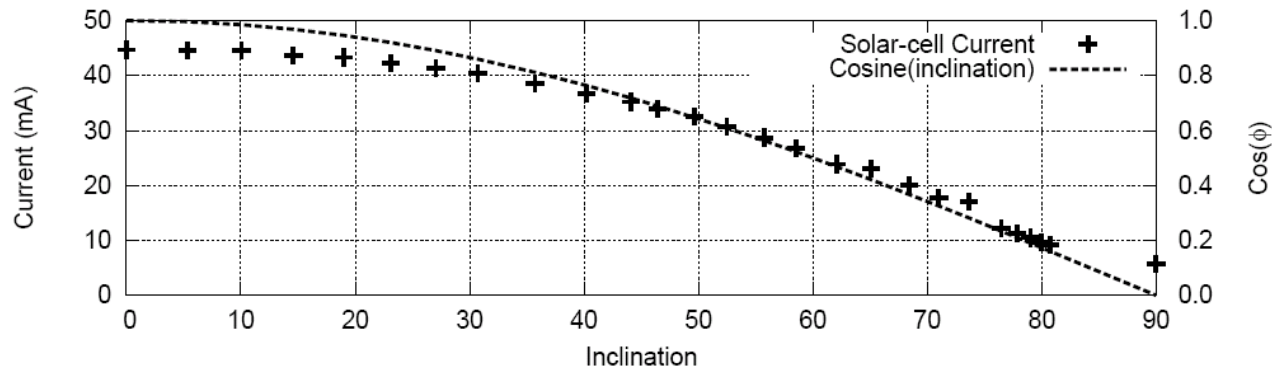

Solar Collector: Solar-cell Characteristics

- Solar-cell I-V curve

- Regulator

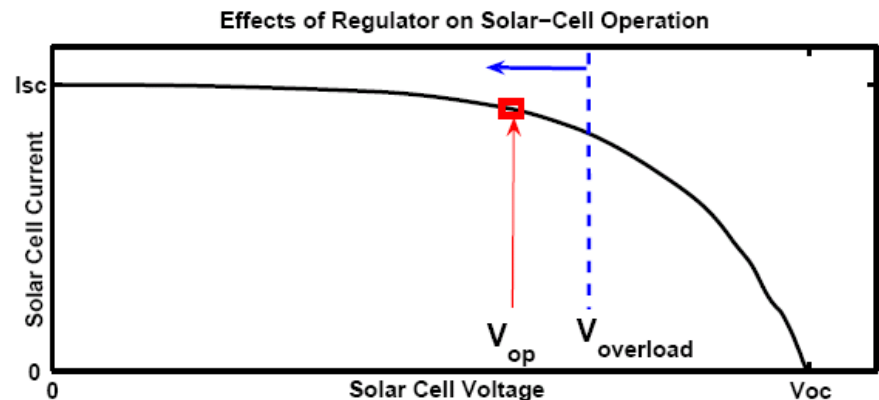
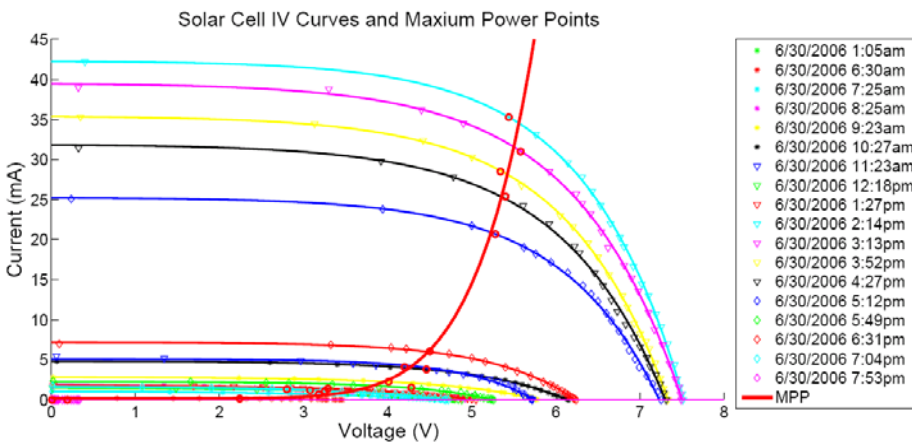
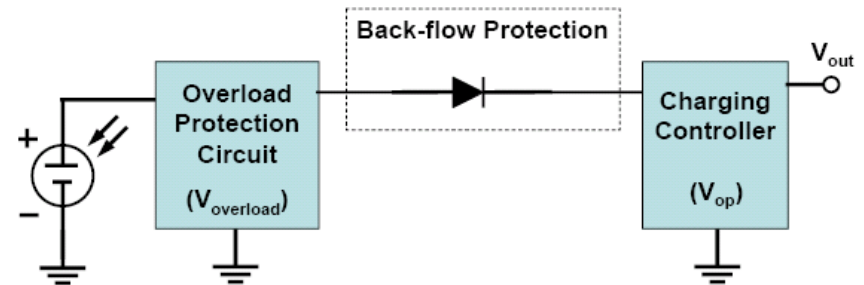
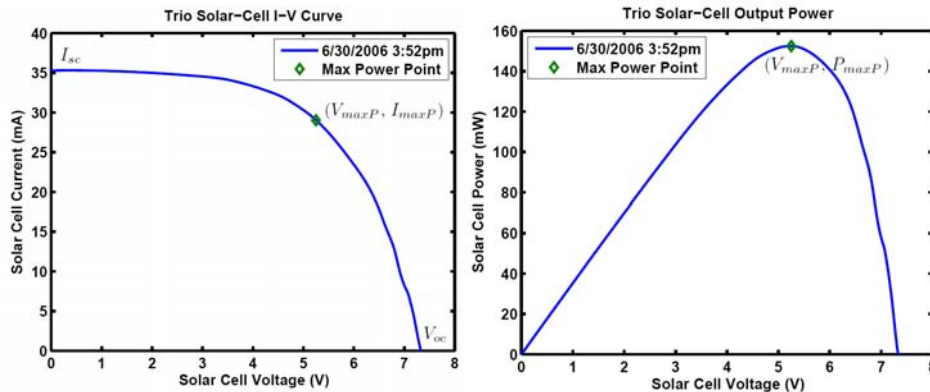

Energy Storage

- Requirements:
 - Lifetime, Capacity, Current draw, Size/Weight
- Types of storage:
 - NiMH: capacity and cost
 - Li⁺: energy density and capacity
 - Supercap: lifetime
- Storage configuration:
 - Combination of battery and supercap provides good lifetime as well as capacity.
- Charging mechanisms:
 - HW vs. SW, Complexity vs. Efficiency

Comparative Study: Solar-Collector Operation

- Compare P_{on} with P_{maxP}
 - a. solar-cell operating point
 - b. maximum possible value

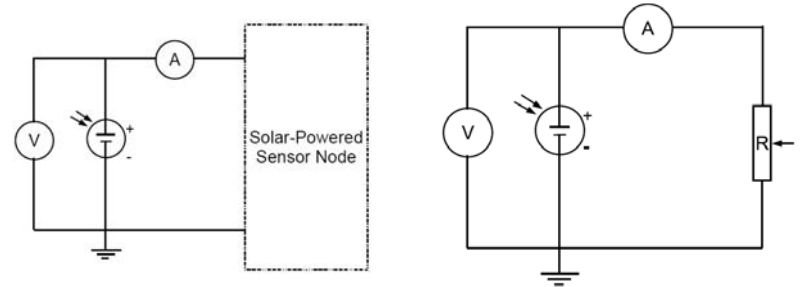

- Trio

$$\begin{aligned}
 - P_{on} - P_{maxP} \\
 = 4.83\text{mW} \\
 (5.3\%)
 \end{aligned}$$

Comparison of solar cell power of Trio mote with the solar cell characteristic (10/8/2006)

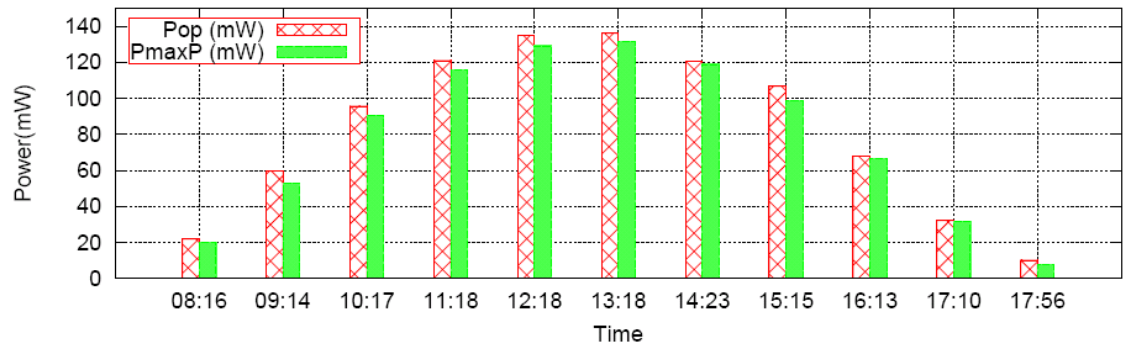

- Heliomote

$$\begin{aligned}
 - P_{on} - P_{maxP} \\
 = -16.75\text{mW} \\
 (-23.2\%)
 \end{aligned}$$

Comparison of solar cell power of Heliomote mote with the solar cell characteristic (10/8/2006)

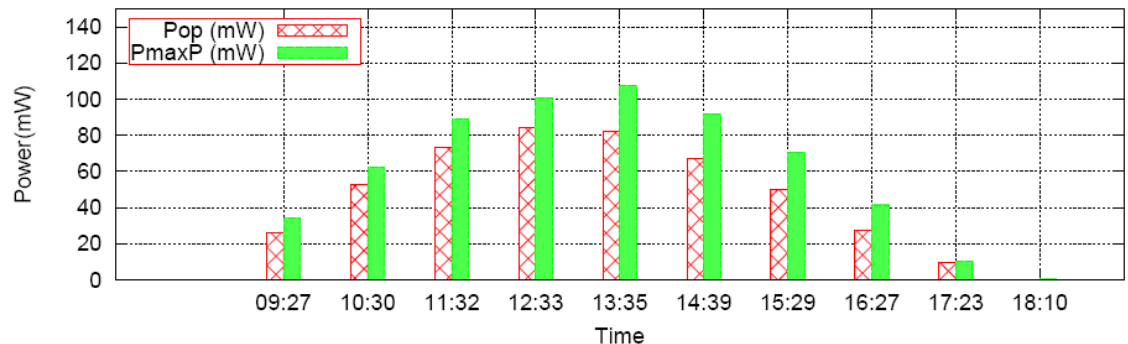

Solar-Collector Operation: Trio

Trio Solar Cell IV Curves and Maximum Power Points

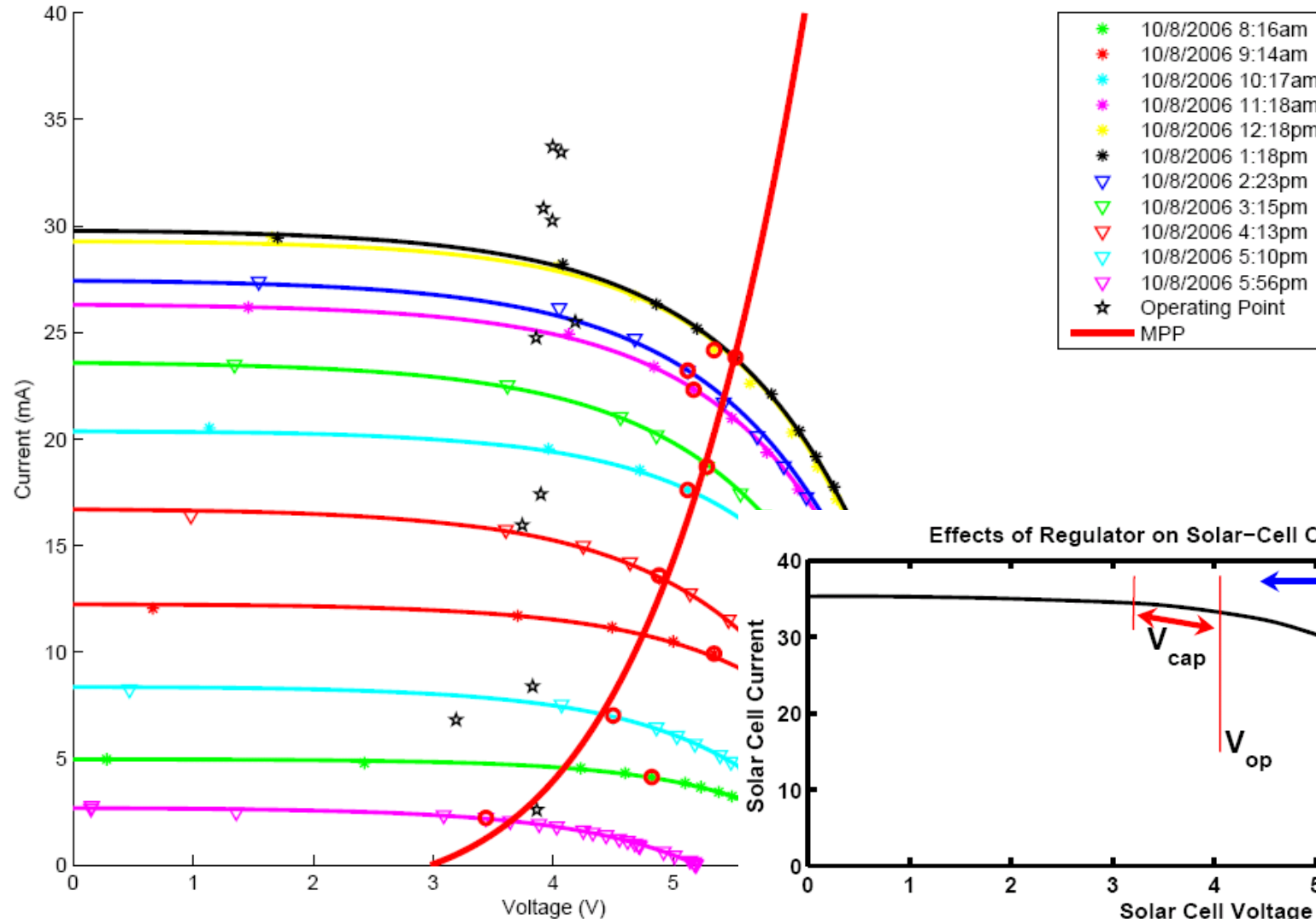

Solar-Collector Operation: Heliomote

Solar Cell IV Curves and Maximum Power Points

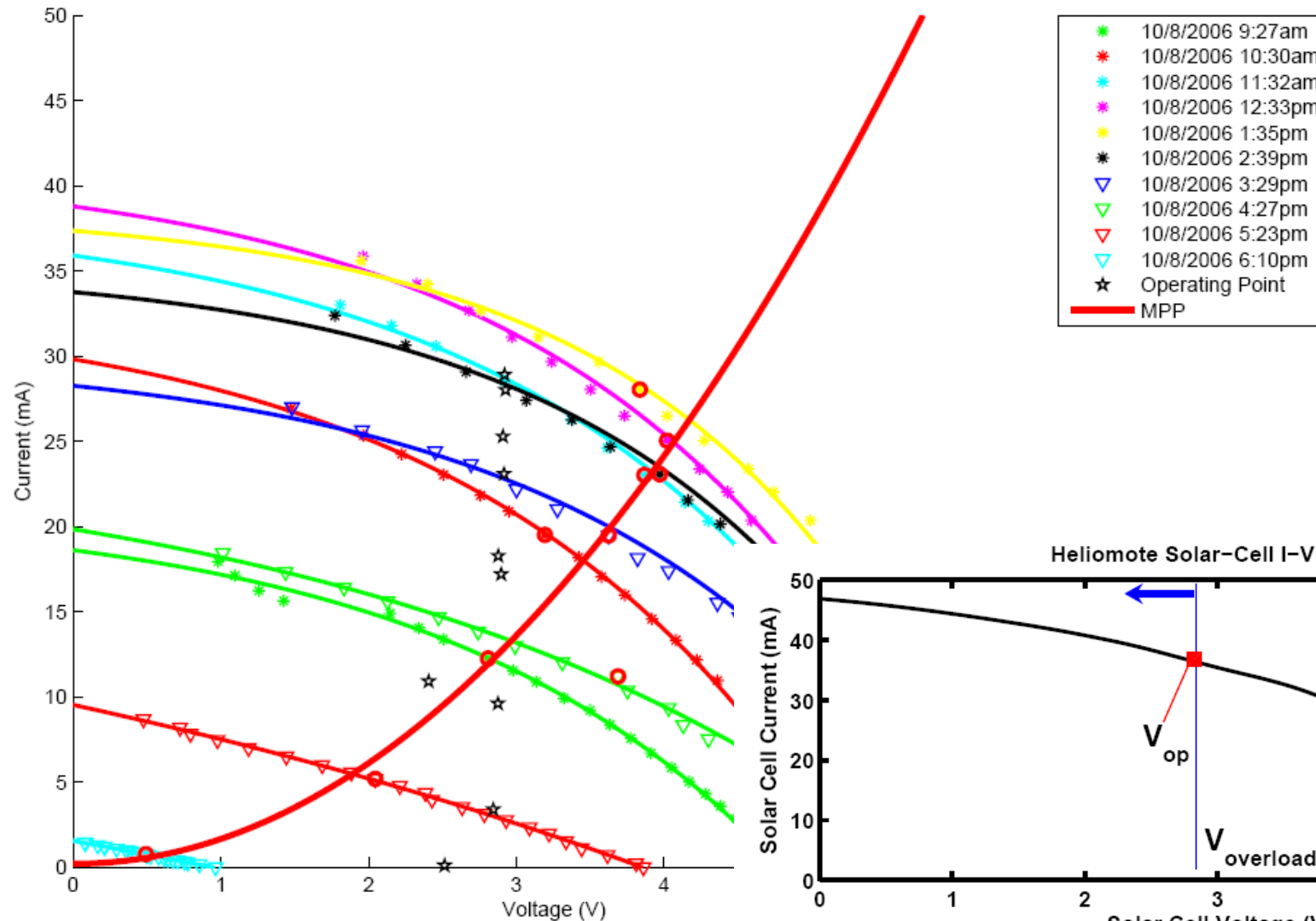

Heliomote Solar-Cell I-V Curve

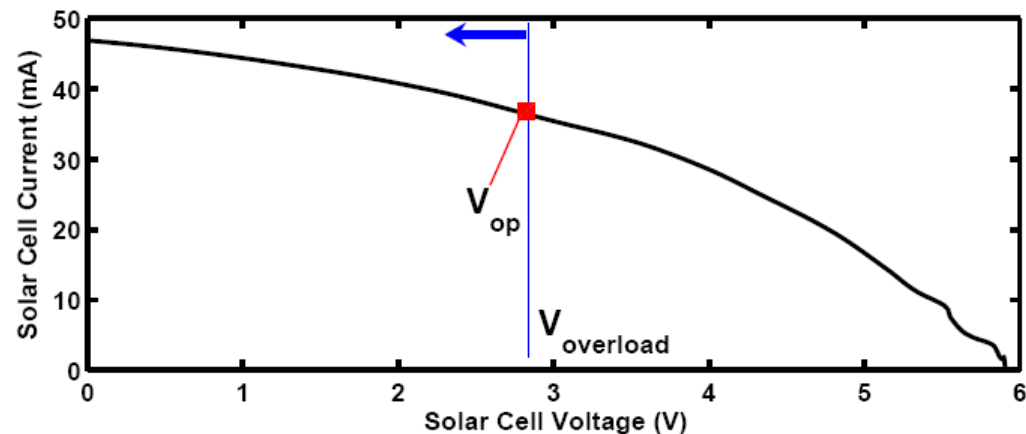

Comparative Study: Energy flow and efficiency

- Compare mote consumption (E_{cons}) and stored energy (E_{bat} and E_{cap}) with solar energy income (E_{sol}).
- Trio: up to 33.4%, Heliomote: up to 14.6%

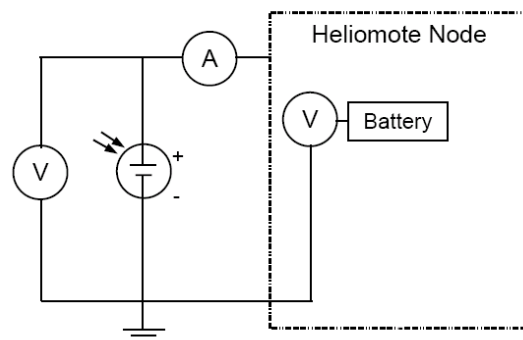
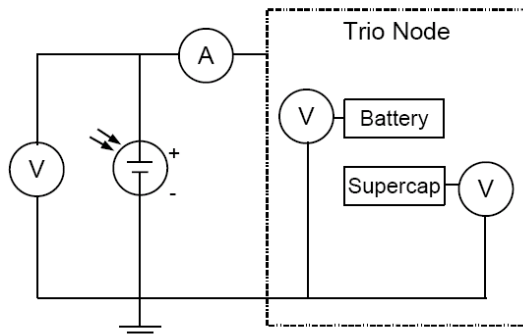

Trio			
Date	10/9	10/11	10/12
ΔE_{sol}	3031.3J	2885.5J	2870.8J
ΔE_{cap}	-0.05J	-0.04J	0.16J
ΔE_{bat}	791.2J	342.1J	348.8J
ΔE_{cons}	221.0J	220.3J	221.0J
$\Delta E_{cap} + \Delta E_{bat} + \Delta E_{cons}$	1012.1J	562.4J	569.6J
$\frac{\Delta E_{cap} + \Delta E_{bat} + \Delta E_{cons}}{\Delta E_{sol}}$	33.4%	19.5%	19.8%
Heliomote			
Date	10/14	10/16	10/18
ΔE_{sol}	1237.6J	1449.9J	1641.4J
ΔE_{cap}	-	-	-
ΔE_{bat}	27.0J	107.3J	10.1J
ΔE_{cons}	103.4J	104.5J	103.0J
$\Delta E_{cap} + \Delta E_{bat} + \Delta E_{cons}$	130.4J	211.8J	113.1J
$\frac{\Delta E_{cap} + \Delta E_{bat} + \Delta E_{cons}}{\Delta E_{sol}}$	10.5%	14.6%	6.9%

Energy flow and efficiency (Heliomote)

- Energy loss due to regulator

- Solar energy income: 08:00 to 17:00.
- Clipped after 12:00.
- Two-third loss in daily energy income.

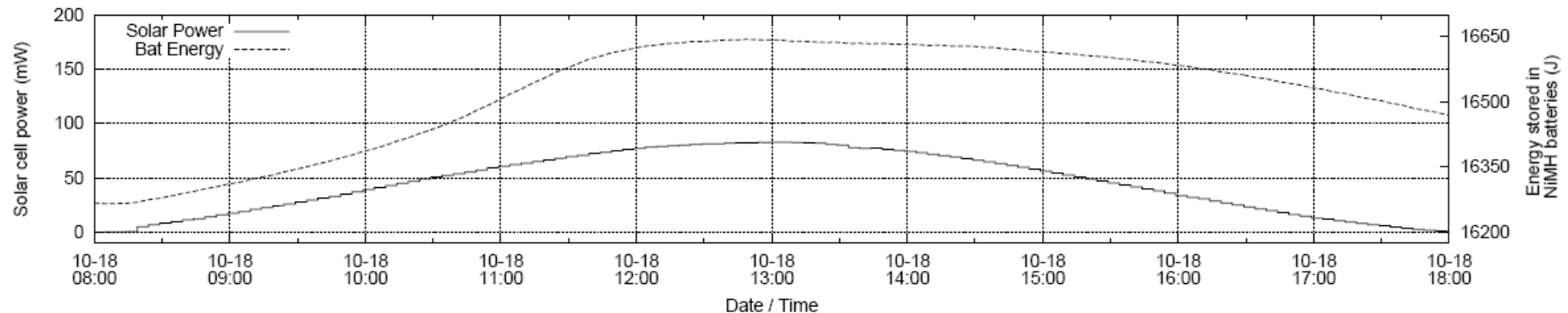
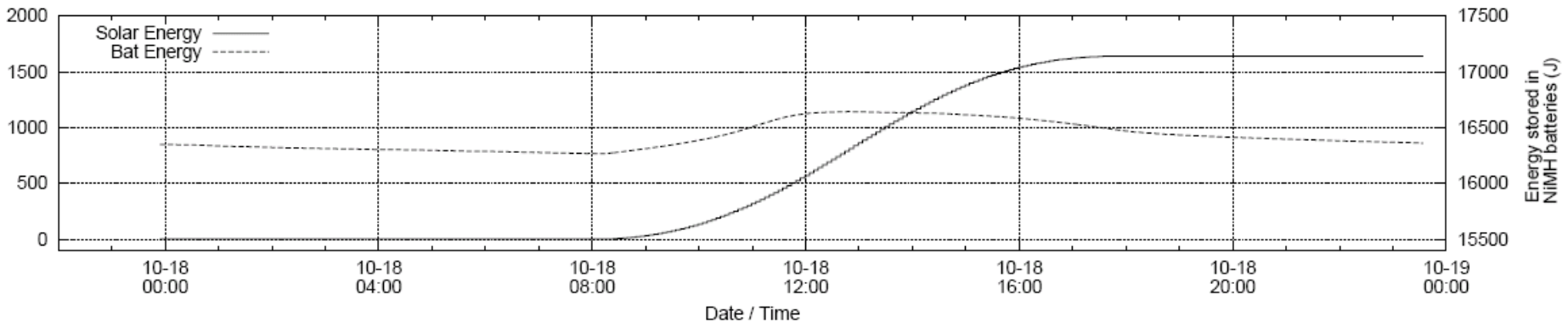

Insights from analysis

- Sensor node:
 - Dynamic duty-cycling for year-round operation.
 - Photo resistor or Coulomb meter for estimating season.
- Environment:
 - Setting inclination is needed for higher solar radiation.
- Solar collector:
 - Operating point for usable output is narrow.
 - Buffering solar-cell with supercap with correct charging and regulator parameters provides close match to maximum output power.
- Energy storage:
 - Lifetime is primary objective.
 - Multi-level storage improves lifetime.