

Automatic Summarization (and other stuff)

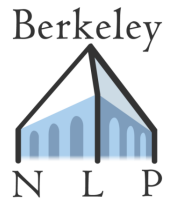

Taylor Berg-Kirkpatrick
CS 288 UC Berkeley



Summarization

Summarization

EDITION: INTERNATIONAL | U.S. | MEXICO | ARABIC
Sign up | US

Home Video World U.S. Africa Asia Europe Latin America Middle East Business World Sport Entertainment Tech Travel

iReport

Lindsay Lohan rejects plea deal

By Alan Duke, CNN
March 24, 2011 — Updated 09:57 GMT (17:57 HKT)

Lindsay Lohan turns down a plea deal that could have resulted in more jail time.

CNN HEROES

EVERYDAY PEOPLE CHANGING THE WORLD

NOMINATE YOUR CNN HERO NOW

Most Popular »
Today's five most popular stories

- Profile: Silvio Berlusconi, Italy's embattled leader
- Women get more Winter Games entries; IOC to draw up gender rules
- Ashley Judd reveals sexual abuse, family pain in memoir
- Facing death, CNN sports legend embraces life
- Quattara forces enter Gbagbo's Ivory Coast stronghold

More

STORY HIGHLIGHTS

- NEW: Lohan lawyer: "She has a strong defense"
- NEW: She tells the prosecutor Wednesday she is rejecting a plea deal
- NEW: A preliminary hearing is set for April 22
- Lohan is charged with stealing a \$2,500 necklace from Kamofie & Company

Los Angeles (CNN) — Lindsay Lohan wants a jury to decide if she's guilty of stealing a necklace from a Venice, California jewelry store, her lawyer said Wednesday.

Her lawyer informed the Los Angeles District Attorney's office Wednesday afternoon that the actress was rejecting a plea deal.

"She has a strong defense and we are confident that a jury will listen to the evidence fairly and acquit her," Shawn Chapman Holley said.

A judge gave Lohan until Wednesday to decide if she would accept a plea deal that would send her to jail for a felony grand theft charge.

"Ms. Lohan has maintained her innocence from the moment this case was filed and she has never wavered," Holley said. "Though many advised her to follow the safe route by taking 'the deal,' the truth is, Ms. Lohan is innocent."

A preliminary hearing is now scheduled for April 22 for a judge to hear evidence to decide if the theft case should go to trial.

The same judge will also decide if Lohan violated her probation for a 2007 drunk driving conviction by being charged with the felony.

The actress is accused of walking out of Kamofie and Company with a \$2,500 necklace around her neck on January 22.

RELATED TOPICS

Lindsay Lohan
Celebrity News

The well-publicized case took a twist this month when it was revealed that a representative of the jewelry store that accused Lohan of theft talked to a book agent about a possible book deal.

BACKSTORY | **MON - FRI**
Los Angeles 2pm
Miami 5pm

Hosted by **Michael Holmes** | **GET STARTED >>**

Powered By Groupon | **Featured Deal | San Francisco**

\$10 for French Fare at the Passion Cafe

Ends on 2011-04-09
\$10 for \$20 Worth of French Fare and Drinks at the Passion Cafe

Highlights
Traditional French fare
Well-appointed wine list
Rooftop dining area

Multidocument Summarization



3NEWS.CO.BZ NEWS
MADELINE SAMRIS AZEEM LINDA GEORGIE JO

Pickering murder accused warned he would kill... awards

Full Story | Share video

Lindsay Lohan pleads not guilty to theft

0 comments | Post Comment

THU, 10 FEB 2011 12:02 PM

Lindsay Lohan pleaded not guilty Wednesday to felony grand theft of a US\$2,500 necklace — a case that could return the troubled starlet to jail rather than the big screen.

She entered the plea through her attorney Shawn Chapman Holley after a judge scolded her about following the law.

"Look around this room," Superior Court Judge Keith Schwartz told Lohan. "Everybody else has to follow the law. There are different from anyone else. So please, don't push your luck."

Schwartz set bail at US\$40,000. He said it appeared Lohan had needed her probation as a 2007 runaway during case and warned that if she violated the law while free on bail he would have her arrested and held.

Lohan spoke little during the hearing except to acknowledge her name and that she understood the charge and the possible consequences.

The *Mean Girls* star was met by a swarm of photographers...

Get a quote now. Save it, then use it online later.



WA Today LIFE & STYLE

CHOOSE QUALITY & ENJOY
GENUINE AUSSIE HOSPITALITY
COMPLIMENTARY BREAD & BUTTER
More than 450 in-store
The largest discount

Beauty | Weddings | Fashion | People | Home & Style | Life | Health | Woodstock | Movies | Culture

You are here: Home > Life & Style > People > Article

Lindsay Lohan charged with theft

February 10, 2011

Join the conversation
View the only journal leading the news. Tell your friends.

Top Life & Style articles

1. Teaching the next crop how to handle
2. Breaking the knowledge
3. True romance
4. Women seek for solutions under the 40-skin
5. Victoria Beckham loses her shine

More Life & Style articles

Story Tools

- Share on Facebook
- Email this story
- Print this story

WA Today Jobs

Associated Property Man...
\$40,000 - \$50,000
East Perth, WA 6004
Administer Duties

Lindsay Lohan pleads not guilty to felony grand theft of a \$2,500 necklace. The US judge said it appeared Lohan needed her probation and gave her a stern warning. Bail was set at \$40,000.

US actress Lindsay Lohan has pleaded not guilty to felony grand theft of a \$2,500 necklace — the most serious charge yet filed against the troubled starlet who has wrestled with drug and alcohol abuse for years.

"You're in a different situation now that a felony has been filed," Superior Court Judge Keith Schwartz scolded Lohan after she entered the plea through her lawyer on Wednesday.



THE DAILY CALLER Login | Register

Home | POLICY | US | ENTERTAINMENT | CRIME | WORLD | SPORTS | BUSINESS | TECH | LIFE

By Adam | Published: 9:11 PM (EST) 2/11 | Updated: 10:02 AM (EST) 2/11

Judge tells Lohan she's no star in his courtroom

LOS ANGELES (AP) — Lindsay Lohan walked into a courtroom to face a felony grand theft charge looking like a million dollars, only to be told by a judge she was no different than anyone else.

Lohan's arraignment on a charge that she stole a \$2,500 necklace from an upscale jeweler wasn't the first time a judge threatened to throw the troubled starlet in jail. But it was the first time a judge wields enough power to keep her locked up for a long time.

"You're in a different situation now that a felony has been filed," Los Angeles Superior Court Judge Keith Schwartz said after the actress pleaded not guilty Wednesday.

"Everybody else has to follow the law," Schwartz said, noting that he was giving the actress a fairer version of a lecture he'd delivered to her attorney behind closed doors and away from the dozens of assembled reporters.

"You're no different than anyone else. So please, don't push your luck."

Teasing the limits — in the courtroom rather than the big screen — has been Lohan's calling card in the case early. Her attorney, Shawn Chapman Holley, indicated Wednesday in which Lohan could opt to end the case early. Her attorney, Shawn Chapman Holley, indicated Wednesday that the actress was interested in an early disposition program if the terms are right.

Sentence Extraction

Lindsay Lohan pleaded not guilty Wednesday to felony grand theft of a 2,500 necklace, a case that could return the troubled starlet to jail rather than the big screen.



Sentence Extraction



Lindsay Lohan pleaded not guilty Wednesday to felony grand theft of a 2,500 necklace, a case that could return the troubled starlet to jail rather than the big screen. Saying it appeared that Lohan had violated her probation in a 2007 drunken driving case the judge set bail at \$40,000 and warned that if Lohan was accused of breaking the law while free he would have her held without bail.



Sentence Extraction



Lindsay Lohan pleaded not guilty Wednesday to felony grand theft of a 2,500 necklace, a case that could return the troubled starlet to jail rather than the big screen. Saying it appeared that Lohan had violated her probation in a 2007 drunken driving case the judge set bail at \$40,000 and warned that if Lohan was accused of breaking the law while free he would have her held without bail. The Mean Girls star is due back in court on Feb. 23 an important hearing in which Lohan could opt to end the case early.

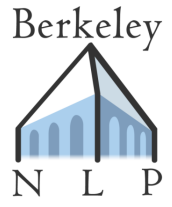

Maximum Marginal Relevance

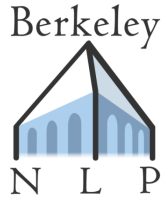

Maximum Marginal Relevance

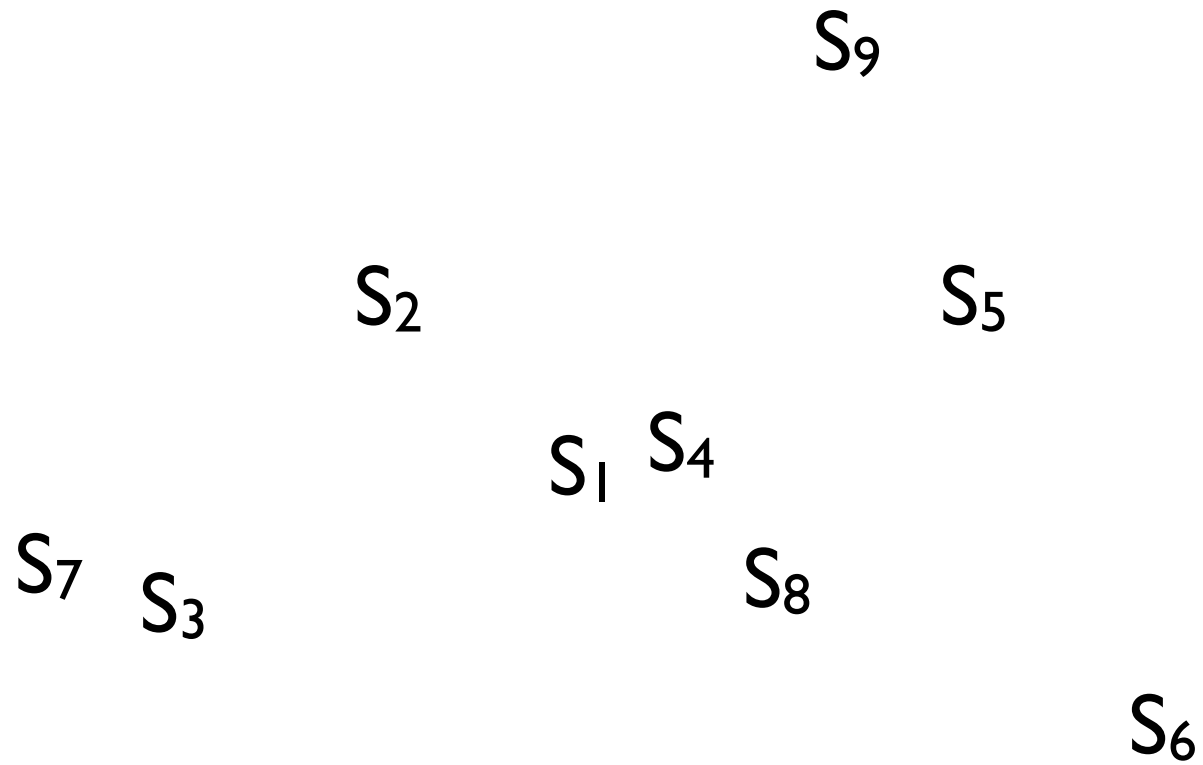

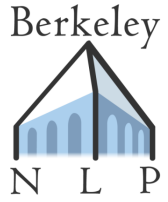

Maximum Marginal Relevance

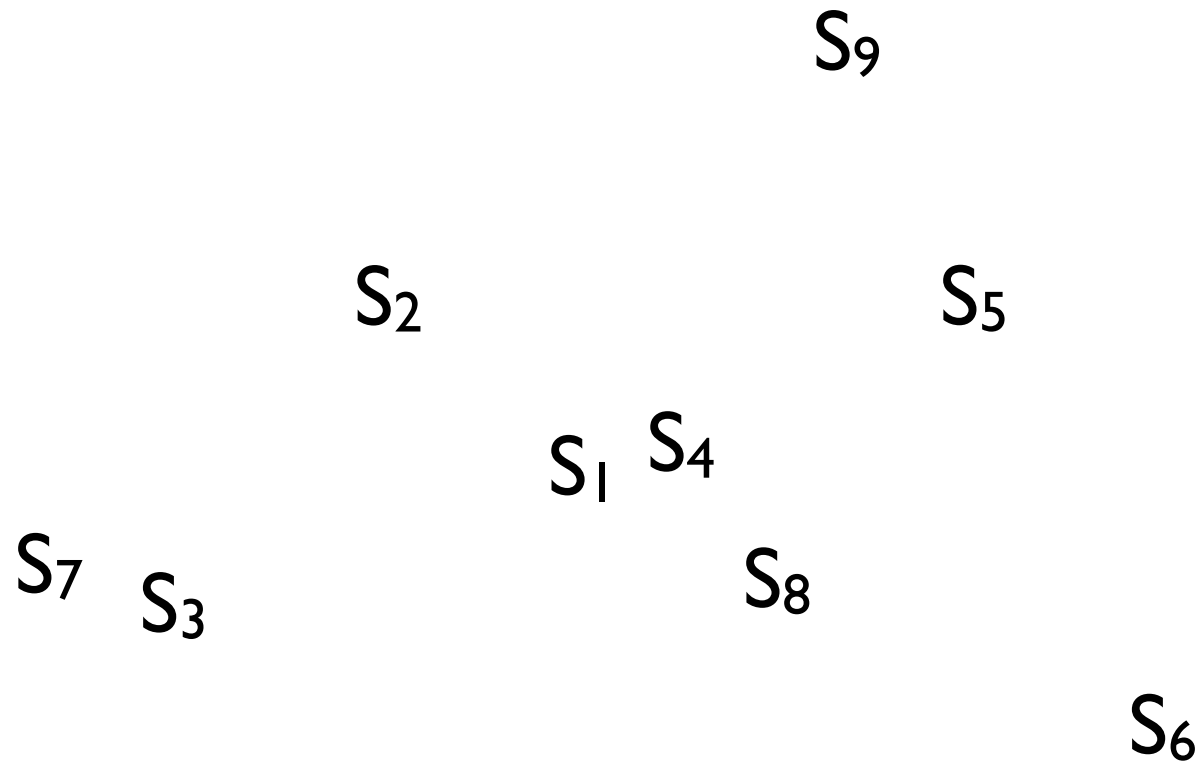

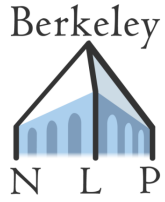

Maximum Marginal Relevance

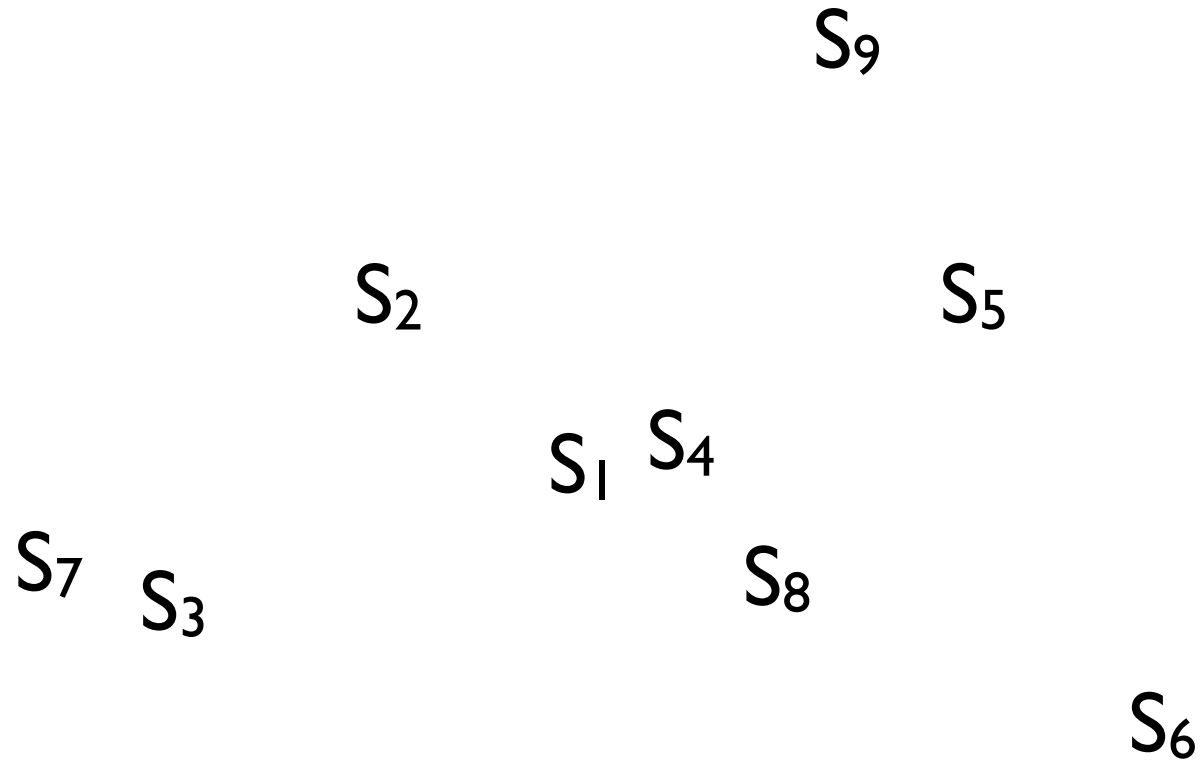

S_1 : She traveled to France on Friday.

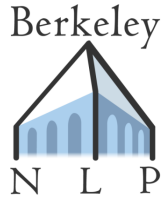

Maximum Marginal Relevance

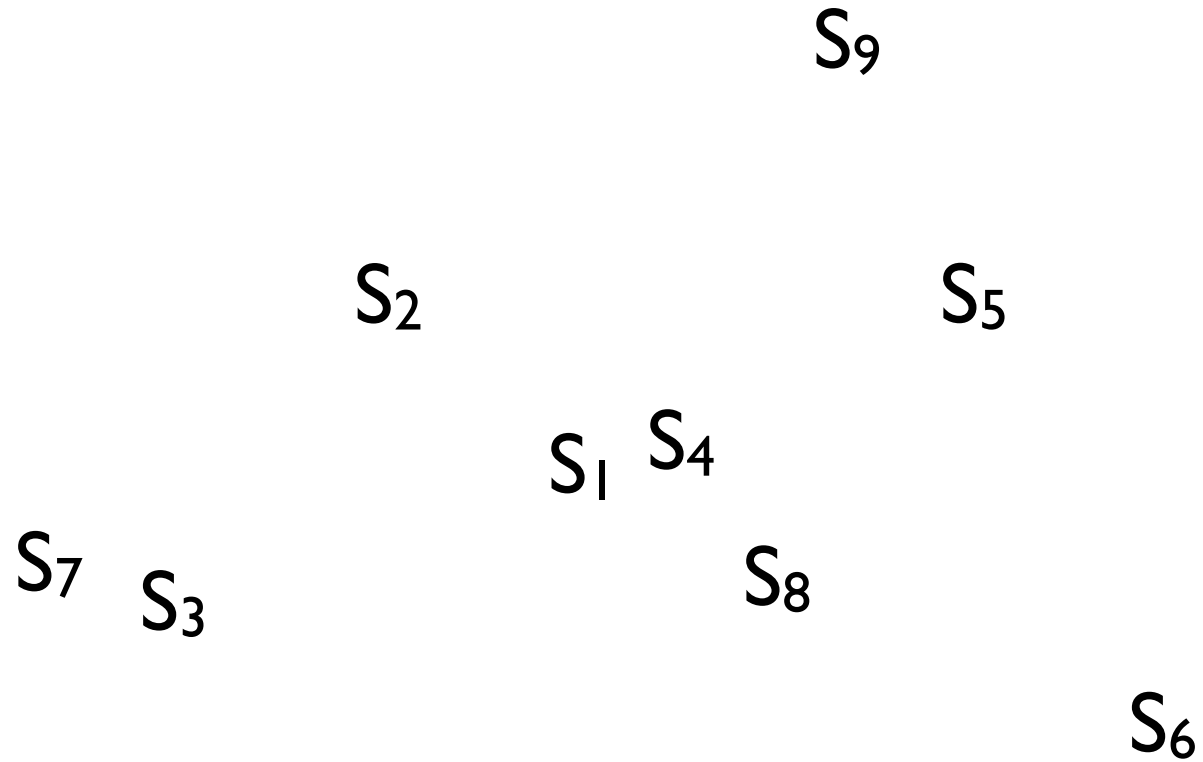

S_1 : She traveled to France on Friday.

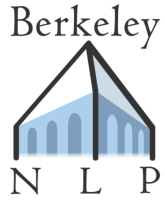

Maximum Marginal Relevance

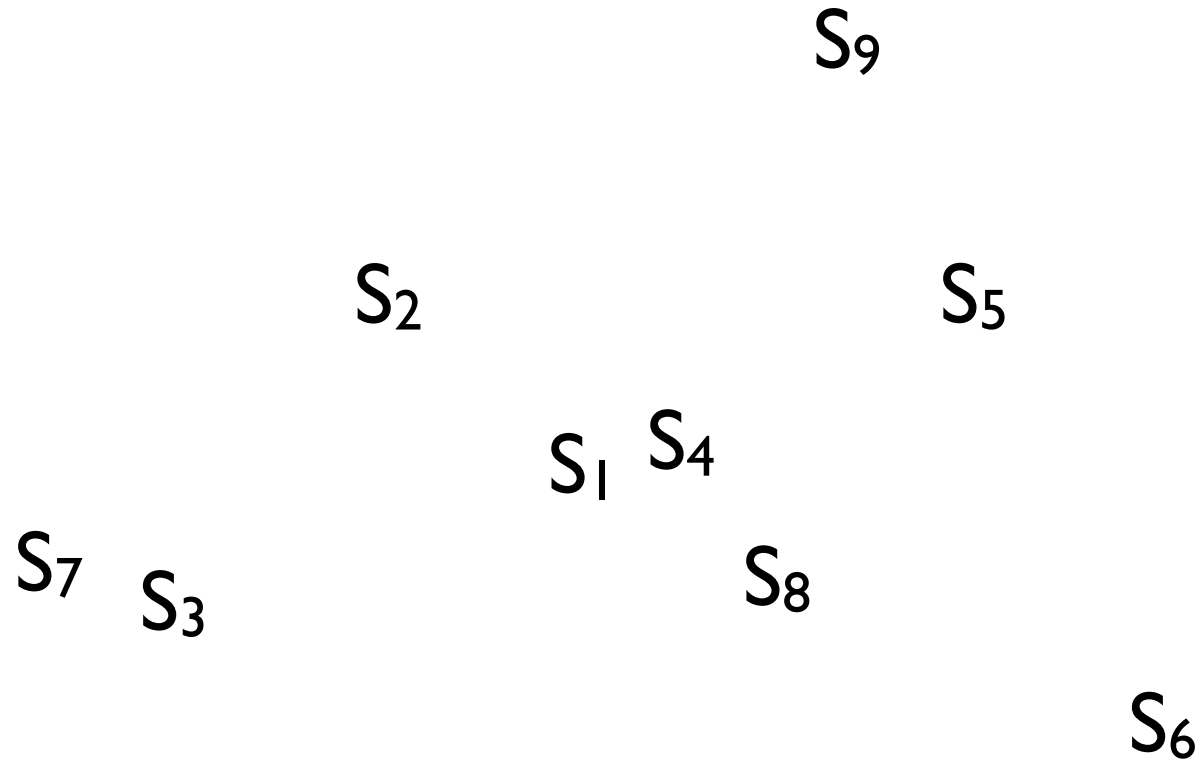

S₁: She traveled to France on Friday.

S₄: On Friday, She took a trip to France.

Maximum Marginal Relevance

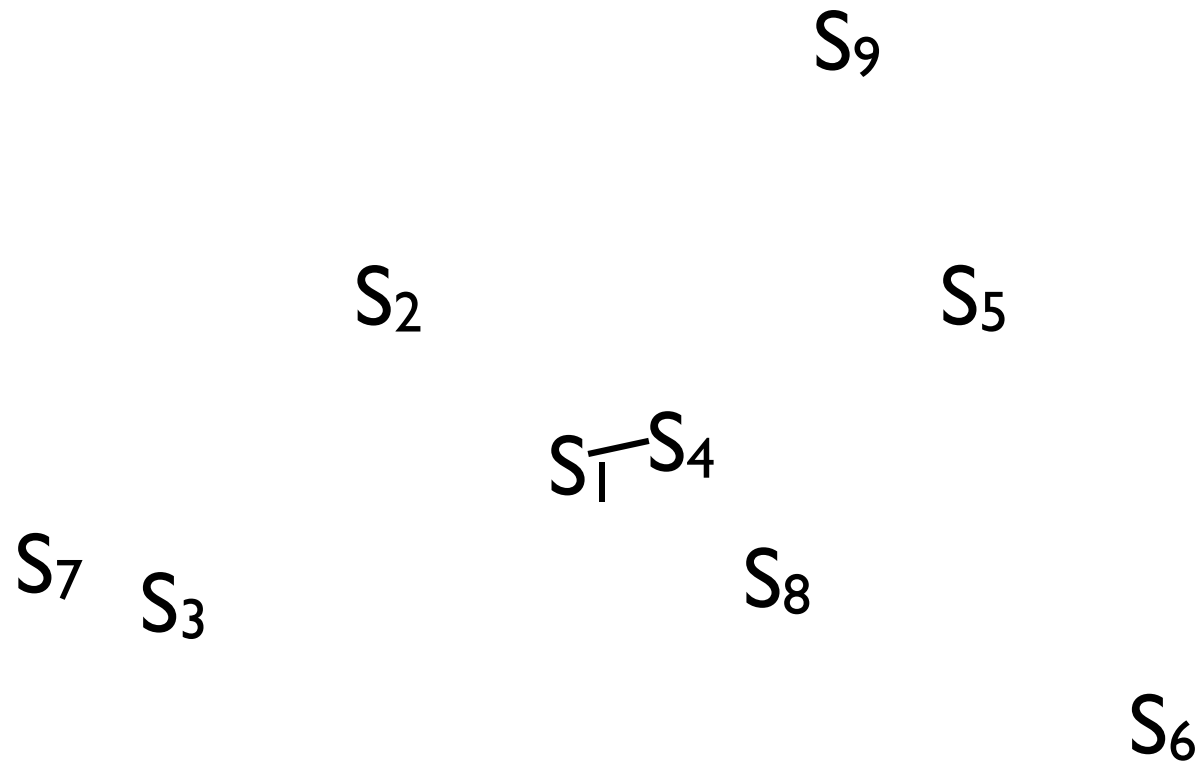

S₁: She traveled to France on Friday.

S₄: On Friday, She took a trip to France.

Maximum Marginal Relevance

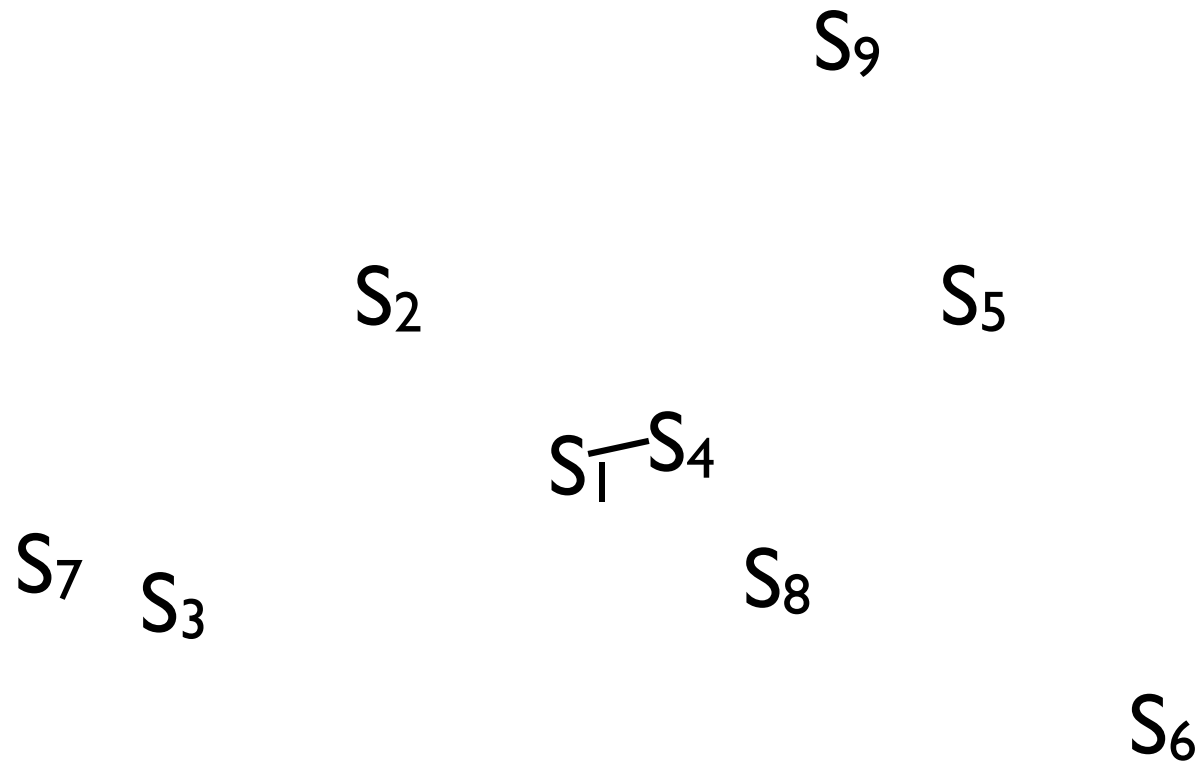

S₁: She traveled to France on Friday.

S₄: On Friday, She took a trip to France.

S₈: She plans to stay for two weeks.

Maximum Marginal Relevance

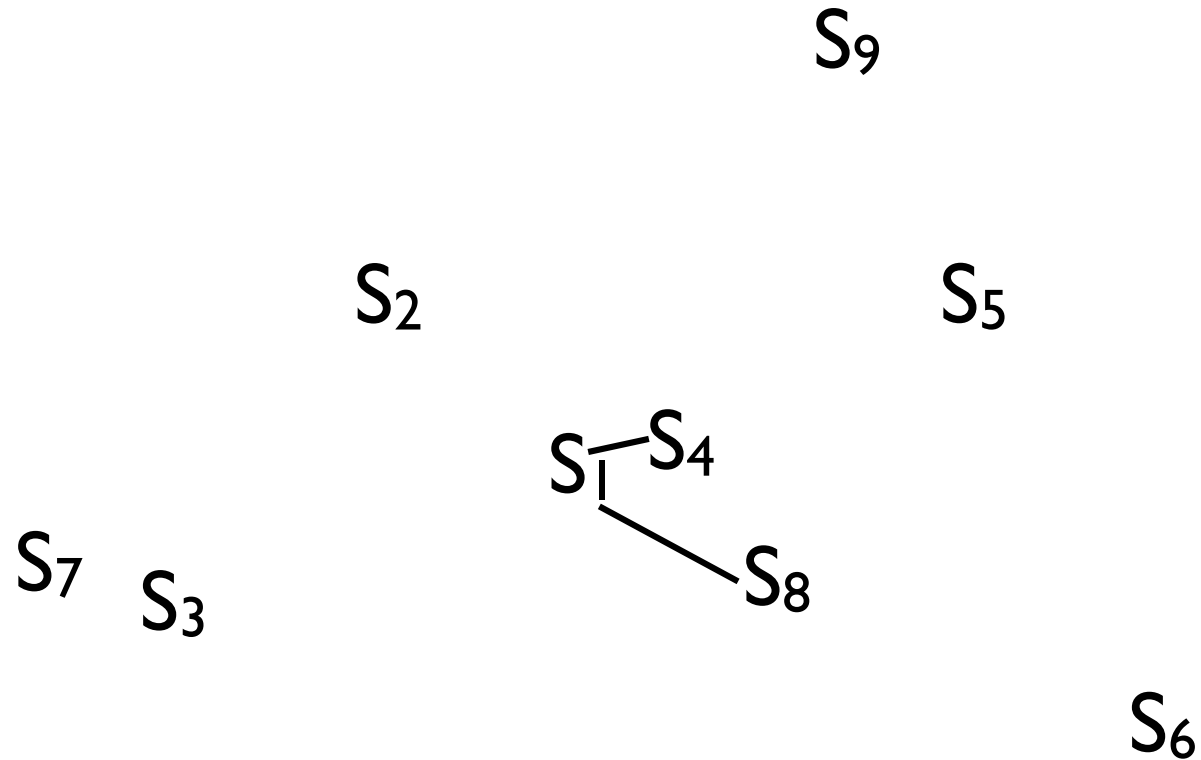

S₁: She traveled to France on Friday.

S₄: On Friday, She took a trip to France.

S₈: She plans to stay for two weeks.

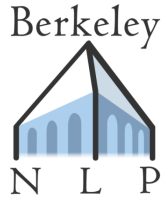

Maximum Marginal Relevance

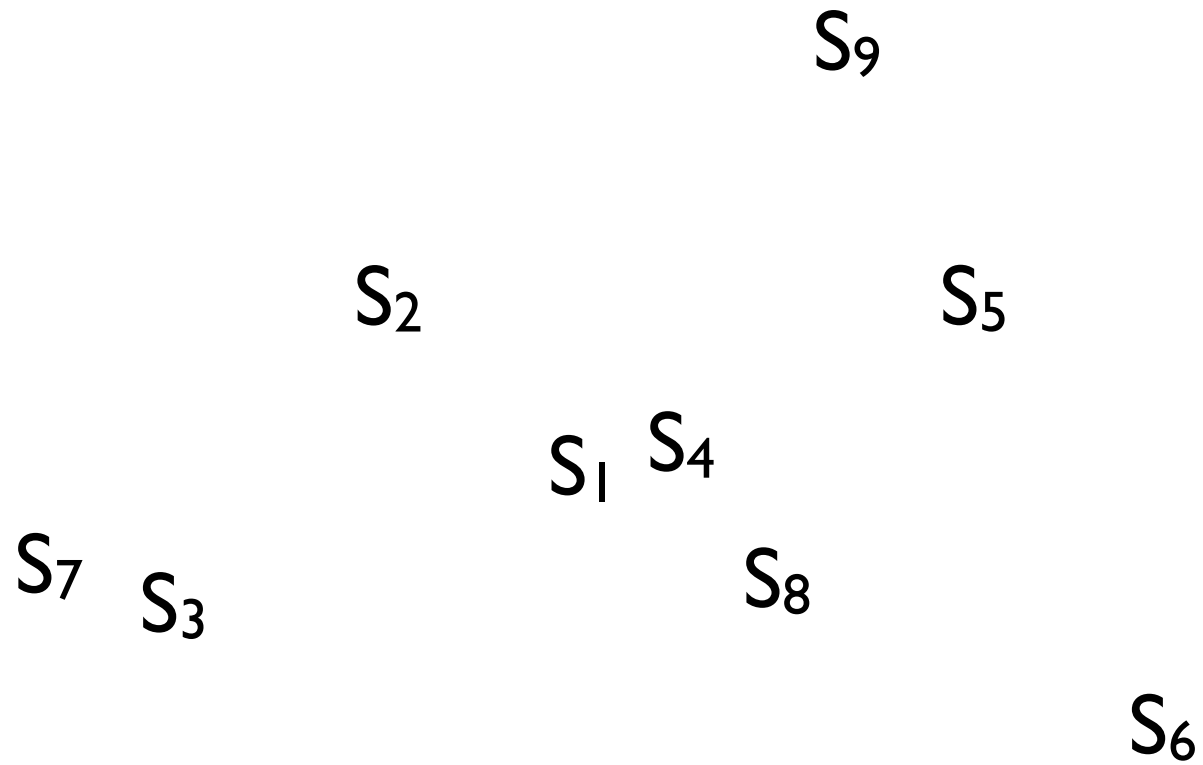

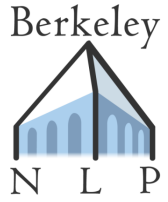

Maximum Marginal Relevance

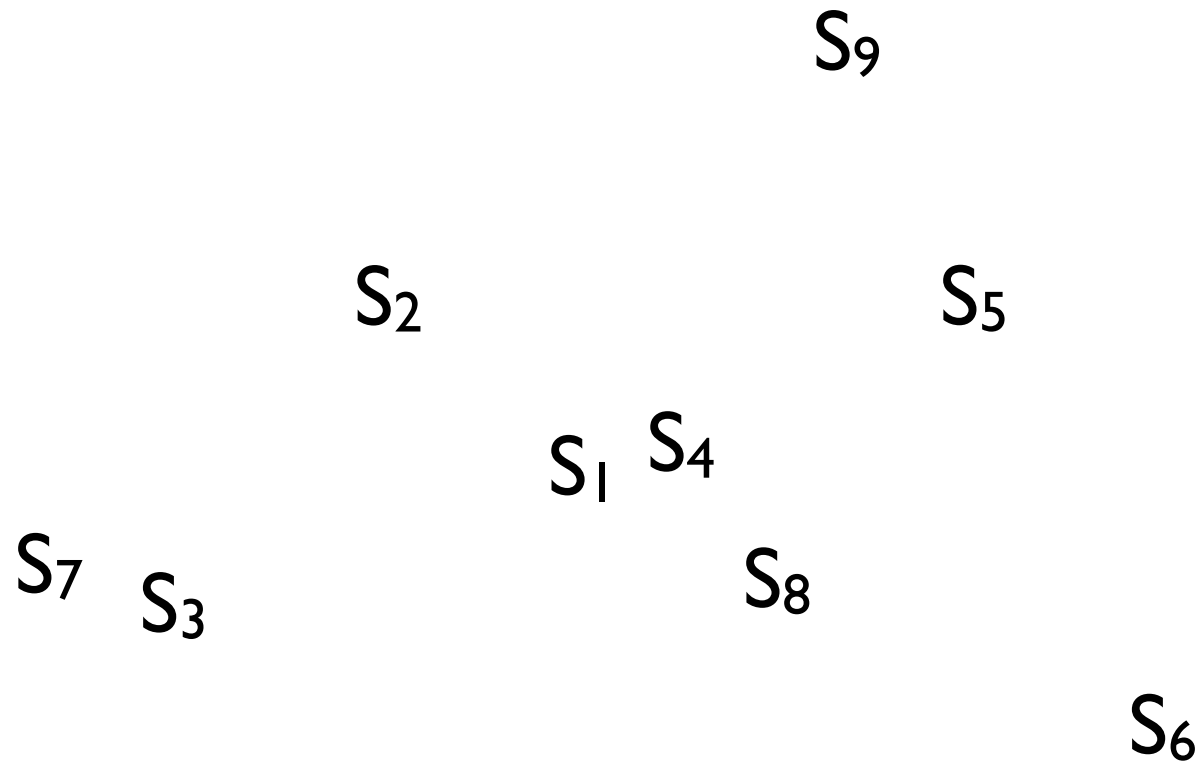

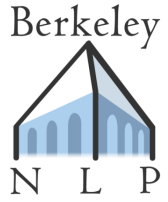

Maximum Marginal Relevance

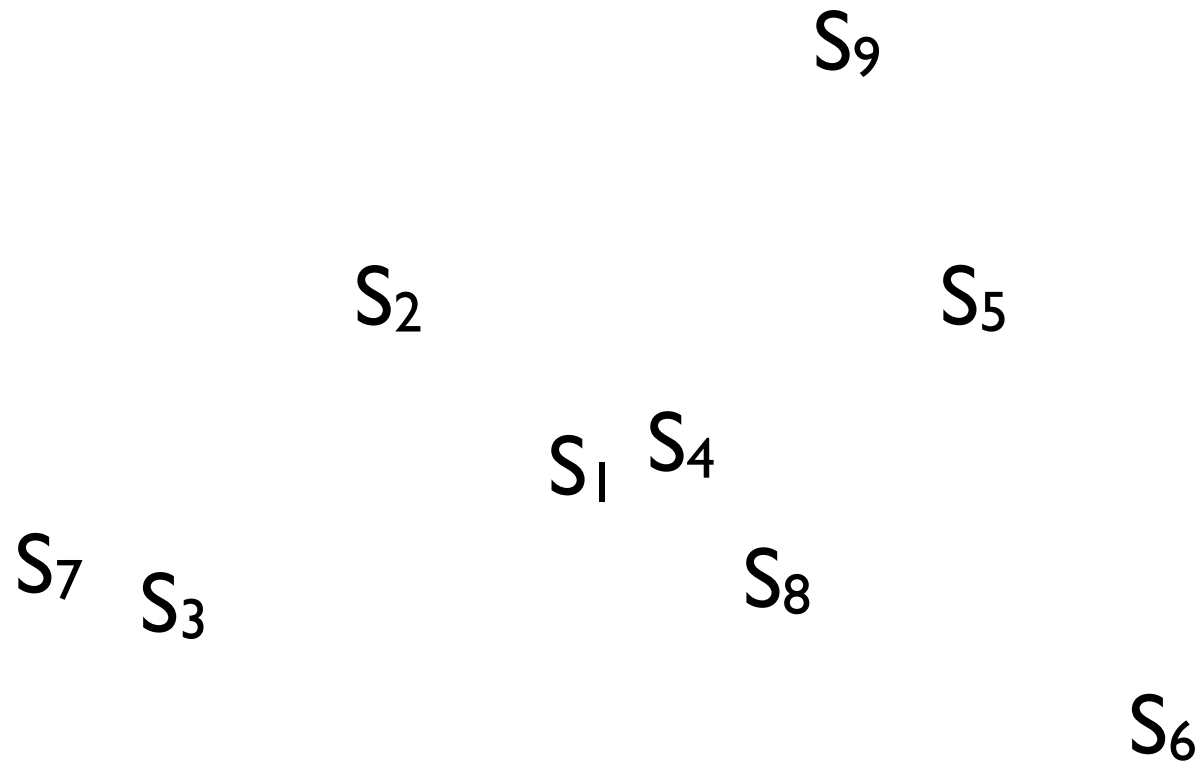

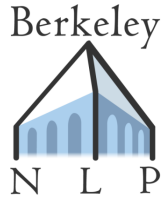

Maximum Marginal Relevance

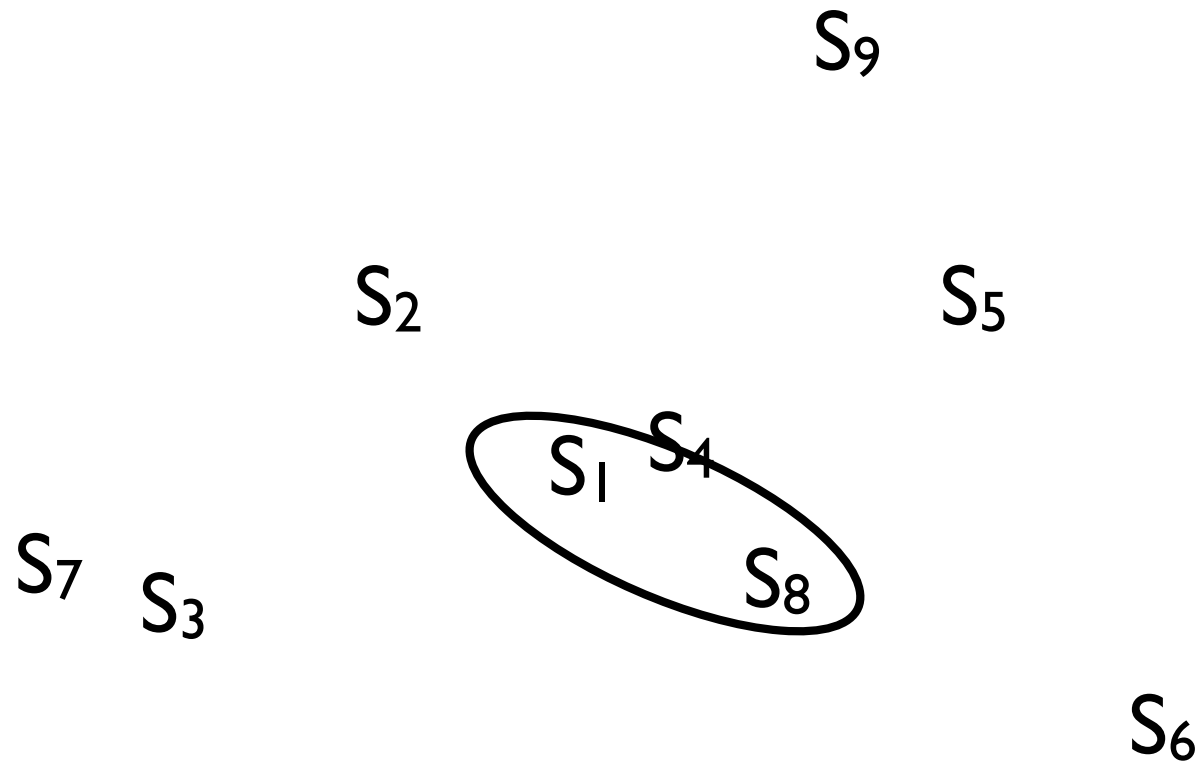

Maximum Marginal Relevance

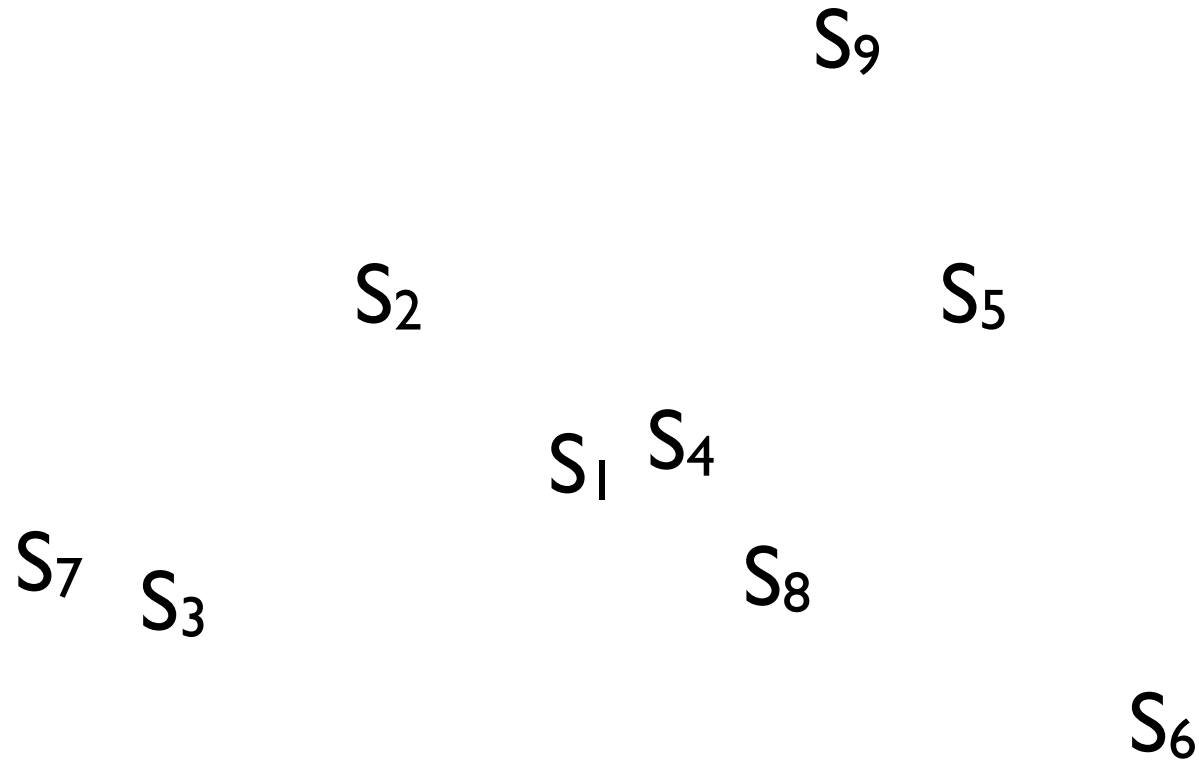

$$\operatorname{argmax}_{i \in D \setminus S} \left[\lambda \cdot \operatorname{sim}(S_i, D) - (1 - \lambda) \cdot \max_j (\operatorname{sim}(S_i, S_j)) \right]$$

Maximum Marginal Relevance

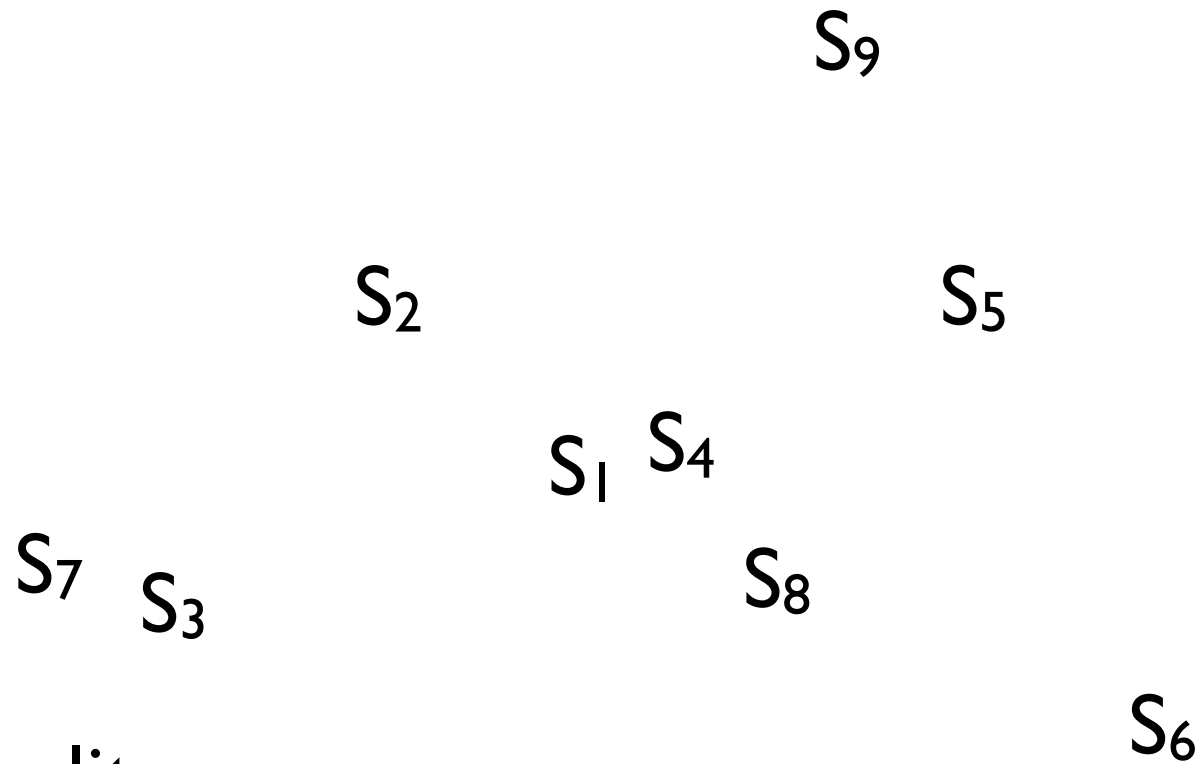

$$\operatorname{argmax}_{i \in D \setminus S} \left[\lambda \cdot \operatorname{sim}(S_i, D) - (1 - \lambda) \cdot \max_j (\operatorname{sim}(S_i, S_j)) \right]$$

Maximum Marginal Relevance

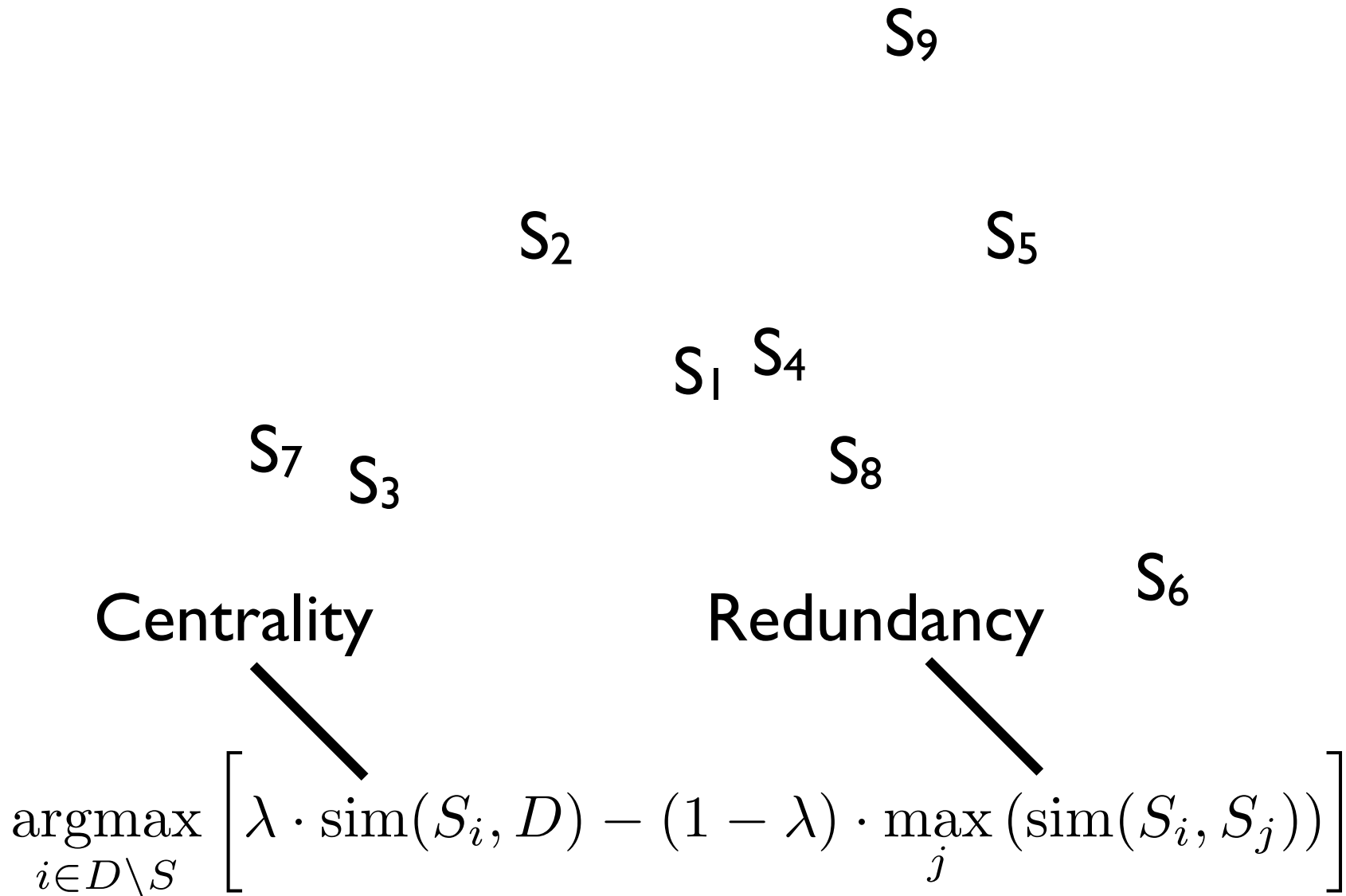

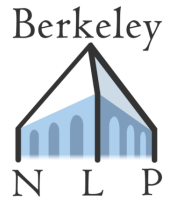

Max Coverage

She stopped in France. In France she remained.

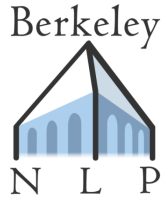

Max Coverage

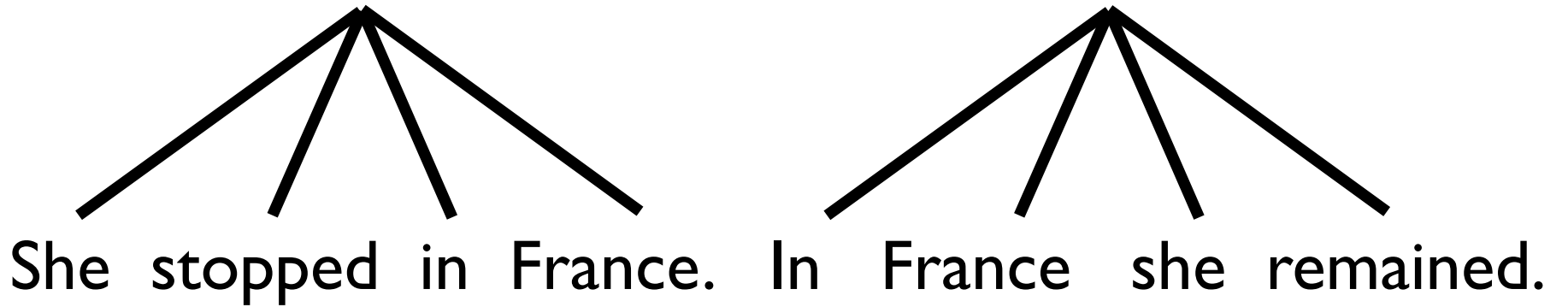

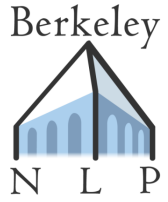

Max Coverage

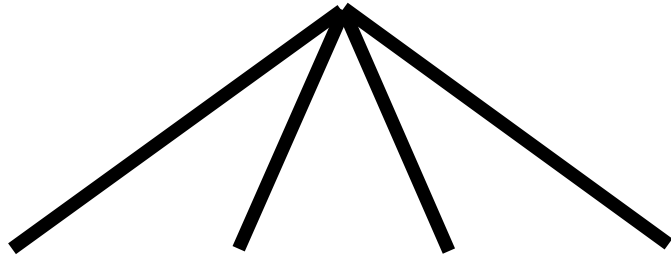

She stopped in France.

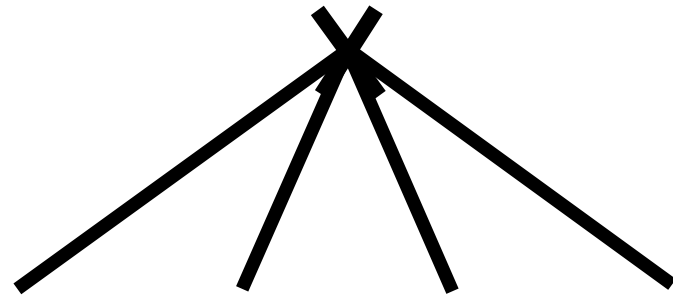

~~In France she remained.~~

Max Coverage

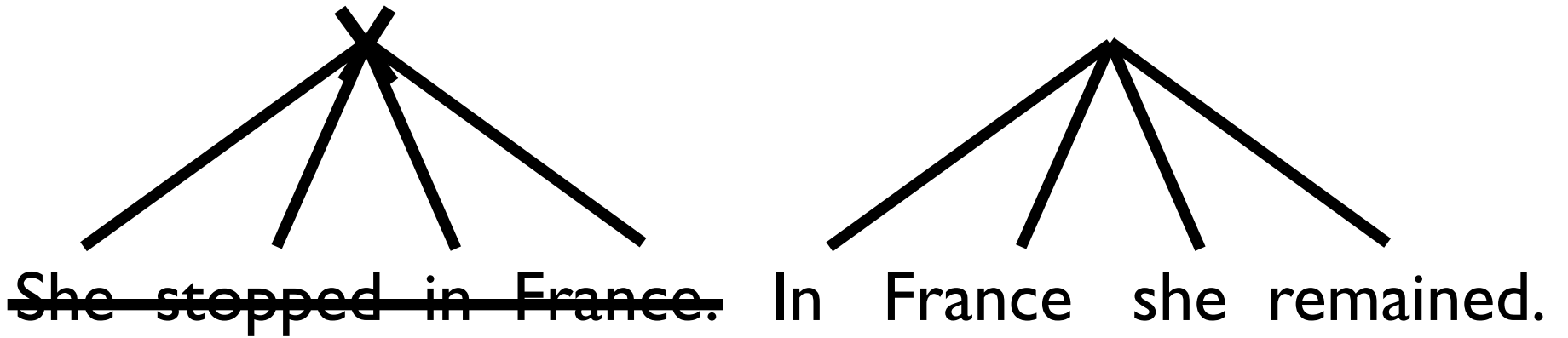

Max Coverage

A summary is a set of cuts: S

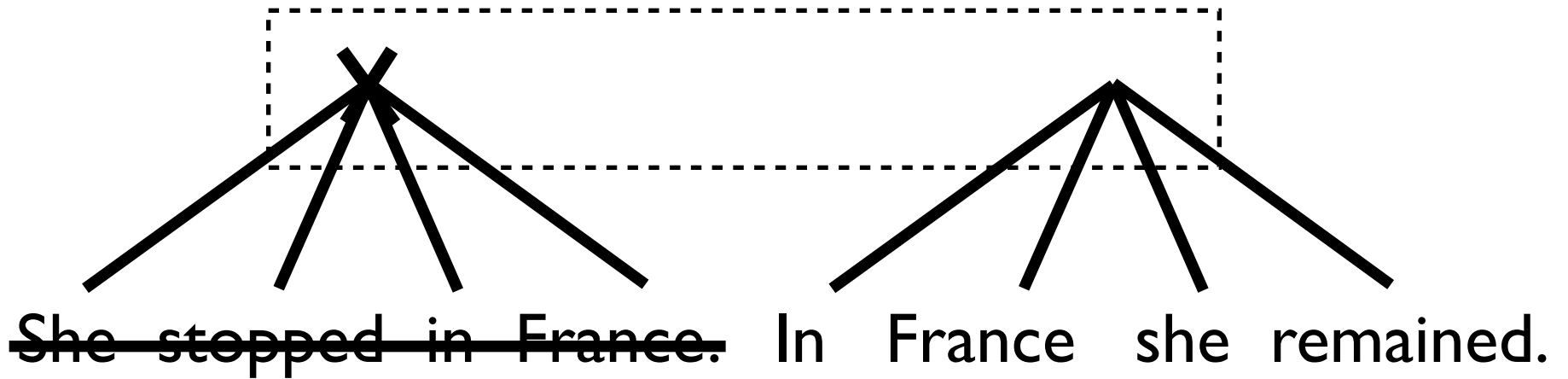

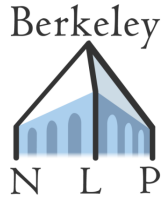

Max Coverage

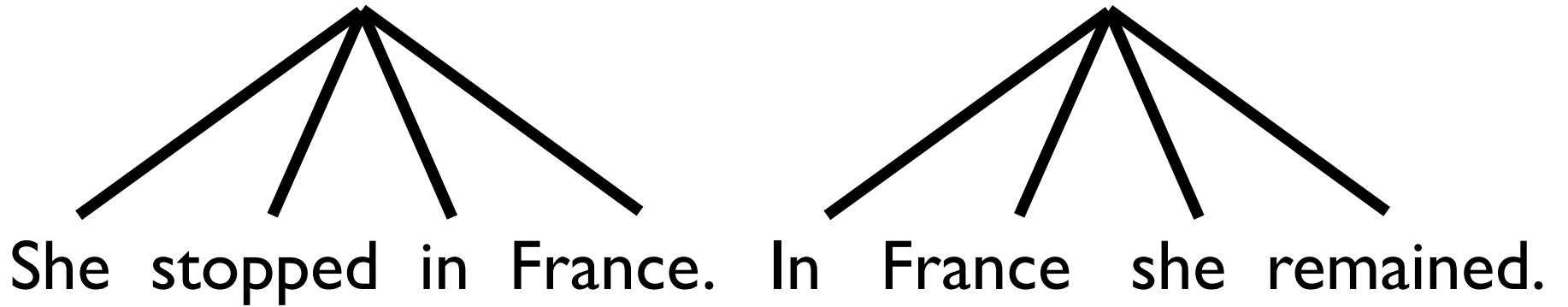

Max Coverage

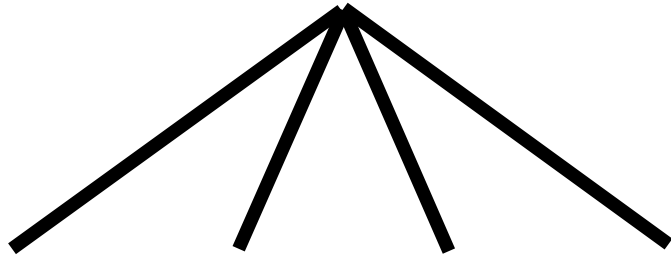

She stopped in France.

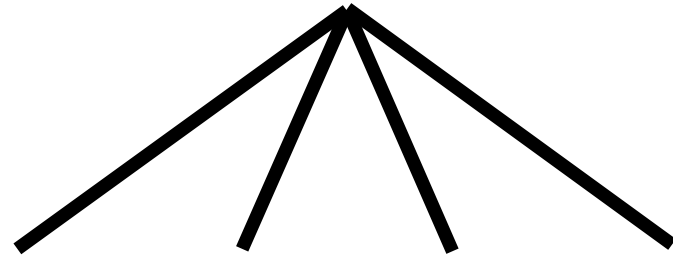

In France she remained.

(she, stopped) ✓
(stopped, in) ✓

(in, france) ✓
(france, she) ✓

(she, remained) ✓

Max Coverage

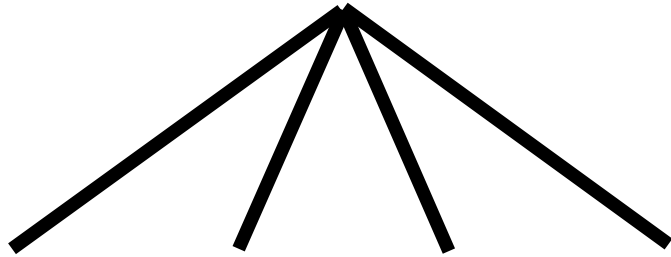

She stopped in France.

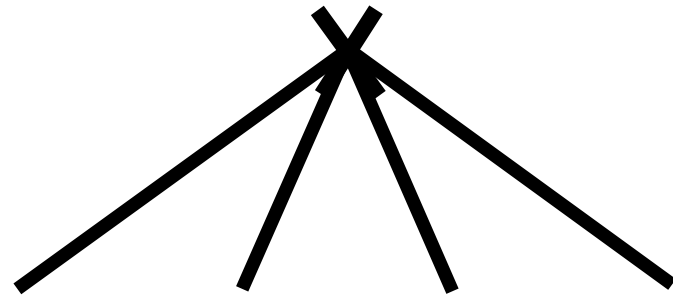

~~In France she remained.~~

(she, stopped) ✓
(stopped, in) ✓

(in, france) ✓
(france, she)

(she, remained)

Max Coverage

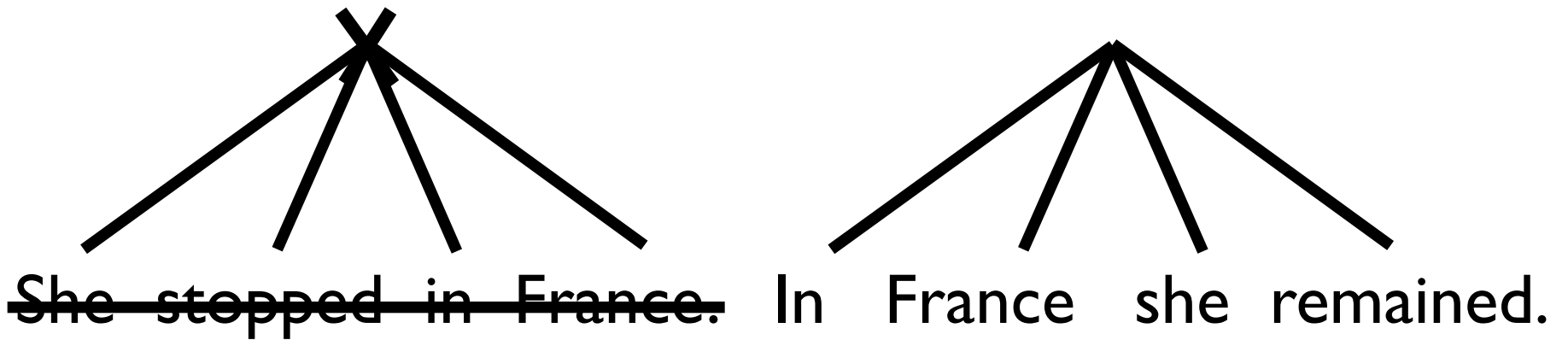

(she, stopped)
(stopped, in)

(in, france) ✓
(france, she) ✓

(she, remained) ✓

Max Coverage

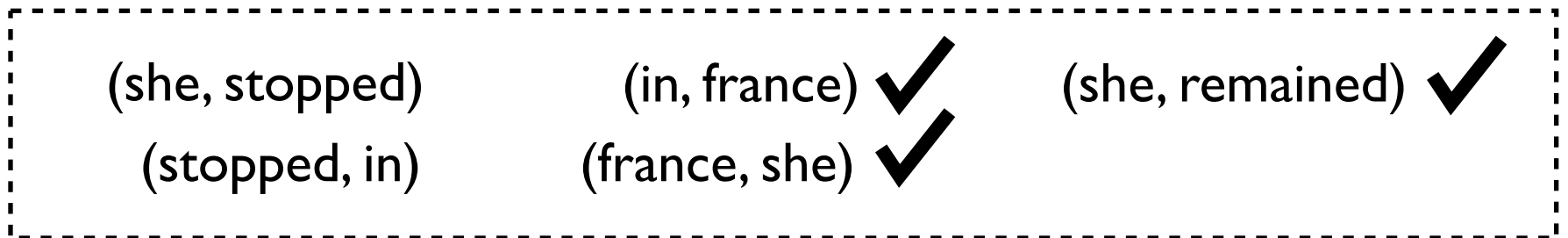
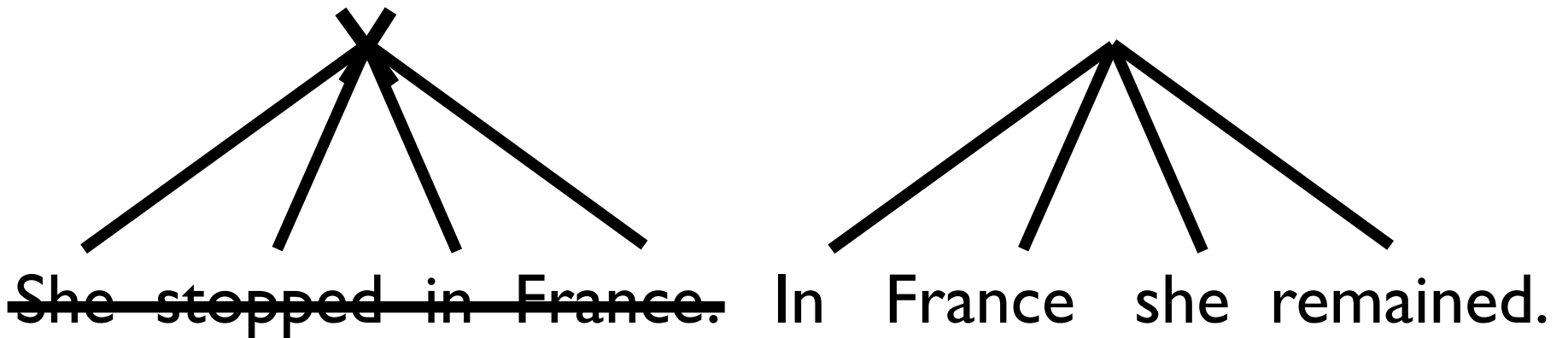

Set of bigrams covered by summary: $B(s)$

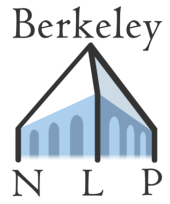

Max Coverage

$$\max_s \text{coverage}(s)$$

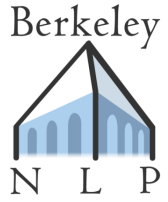

Max Coverage

$$\max_s \text{ coverage}(s)$$

$$s.t. \text{ length}(s) \leq L_{max}$$

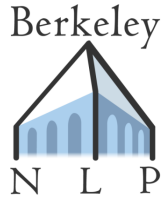

Max Coverage

$$\max_s \sum_{b \in B(s)} \text{value}(b)$$

$$s.t. \text{ length}(s) \leq L_{max}$$

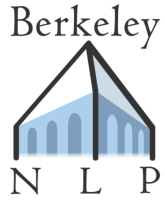

Max Coverage

$$\max_s \sum_{b \in B(s)} \text{value}(b)$$

$$s.t. \text{ length}(s) \leq L_{max}$$

$$\text{value}(b) = \text{freq}(b)$$

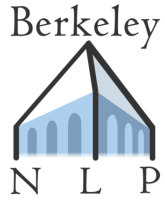

Max Coverage

$$\max_s \sum_{b \in B(s)} \text{value}(b)$$

$$s.t. \text{ length}(s) \leq L_{max}$$

$$\text{value}(b) = \text{freq}(b)$$

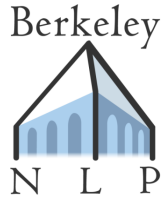

$$\max_s \sum_{b \in B(s)} \text{value}(b)$$

$$s.t. \text{ length}(s) \leq L_{max}$$

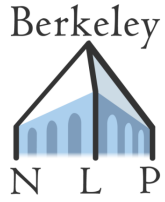

ILP for Decoding

$$\max_s \sum_{b \in B(s)} \text{value}(b)$$

$$s.t. \text{ length}(s) \leq L_{max}$$

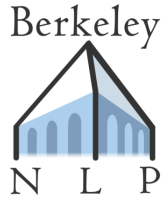

ILP for Decoding

$$\max_{s, z} \sum_b z_b \cdot \text{value}(b)$$

$$s.t. \quad \text{length}(s) \leq L_{max}$$

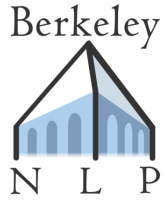

ILP for Decoding

$$\max_{s, z} \sum_b z_b \cdot \text{value}(b)$$

$$s.t. \quad \text{length}(s) \leq L_{max}$$

bigrams in s are covered

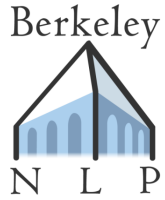

ILP for Decoding

$$\max_{s, z} \sum_b z_b \cdot \text{value}(b)$$

$$s.t. \quad \text{length}(s) \leq L_{max}$$

bigrams in s are covered

only bigrams in s are covered

ILP for Decoding

$$\max_{s, z} \sum_b z_b \cdot \text{value}(b)$$

$$s.t. \sum_n l_n s_n \leq L_{\max}$$

$$\forall_{n, b} \quad s_n Q_{nb} \leq z_b$$

$$\forall_b \quad \sum_n s_n Q_{nb} \geq z_b$$

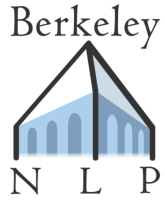

Linear Model for Extraction

$$\max_s \sum_{b \in B(s)} \text{value}(b)$$

$$s.t. \quad \text{length}(s) \leq L_{max}$$

$$\text{value}(b) = \text{freq}(b)$$

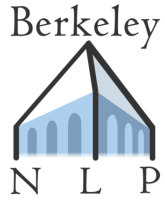

Linear Model for Extraction

$$\max_s \sum_{b \in B(s)} \text{value}(b)$$

$$s.t. \quad \text{length}(s) \leq L_{max}$$

Parameterize using features:

$$\text{value}(b) = w^\top f(b)$$

Sentence Extraction



Lindsay Lohan pleaded not guilty Wednesday to felony grand theft of a 2,500 necklace, a case that could return the troubled starlet to jail rather than the big screen. Saying it appeared that Lohan had violated her probation in a 2007 drunken driving case the judge set bail at \$40,000 and warned that if Lohan was accused of breaking the law while free he would have her held without bail. The Mean Girls star is due back in court on Feb. 23 an important hearing in which Lohan could opt to end the case early.

Extraction and Compression

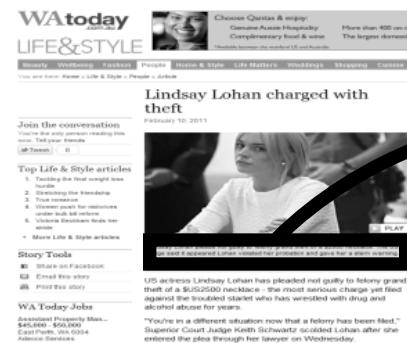

Lindsay Lohan pleaded not guilty ~~Wednesday~~ to felony grand theft of a 2,500 necklace, ~~a case that could return the troubled starlet to jail rather than the big screen.~~ Saying it appeared that Lohan had violated her probation in a 2007 drunken driving case the judge set bail at \$40,000 ~~and warned that if Lohan was accused of breaking the law while free he would have her held without bail.~~ The Mean Girls star is due back in court on Feb. 23 ~~an important hearing in which Lohan could opt to end the case early.~~

Extraction and Compression



Lindsay Lohan pleaded not guilty ~~Wednesday~~ to felony grand theft of a 2,500 necklace, ~~a case that could return the troubled starlet to jail rather than the big screen.~~ Saying it appeared that Lohan had violated her probation in a 2007 drunken driving case the judge set bail at \$40,000 ~~and warned that if Lohan was accused of breaking the law while free he would have her held without bail.~~ The Mean Girls star is due back in court on Feb. 23 ~~an important hearing in which Lohan could opt to end the case early.~~

[Martins and Smith 2009]
[Woodsend and Lapata 2010]

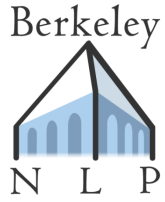

Extraction and Compression

She stopped in France. ~~In France~~ she remained.

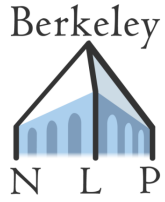

Joint Extractive / Compressive Model

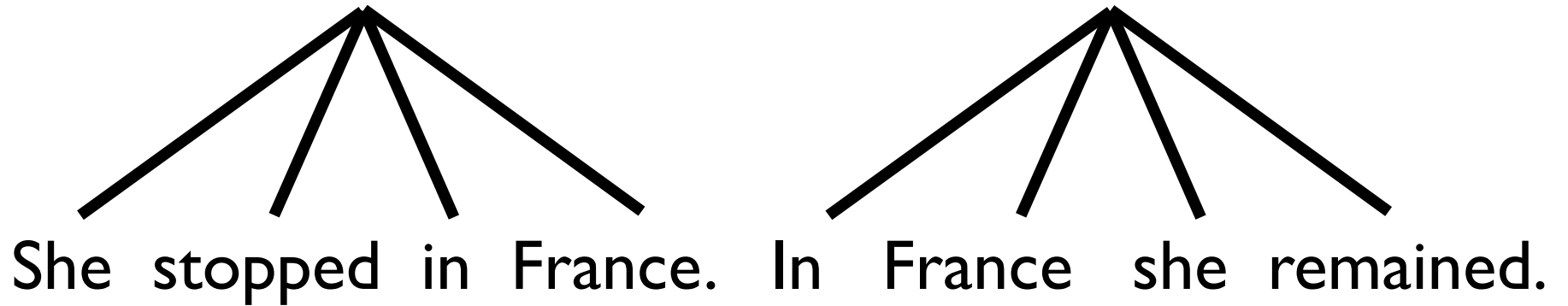

Joint Extractive / Compressive Model

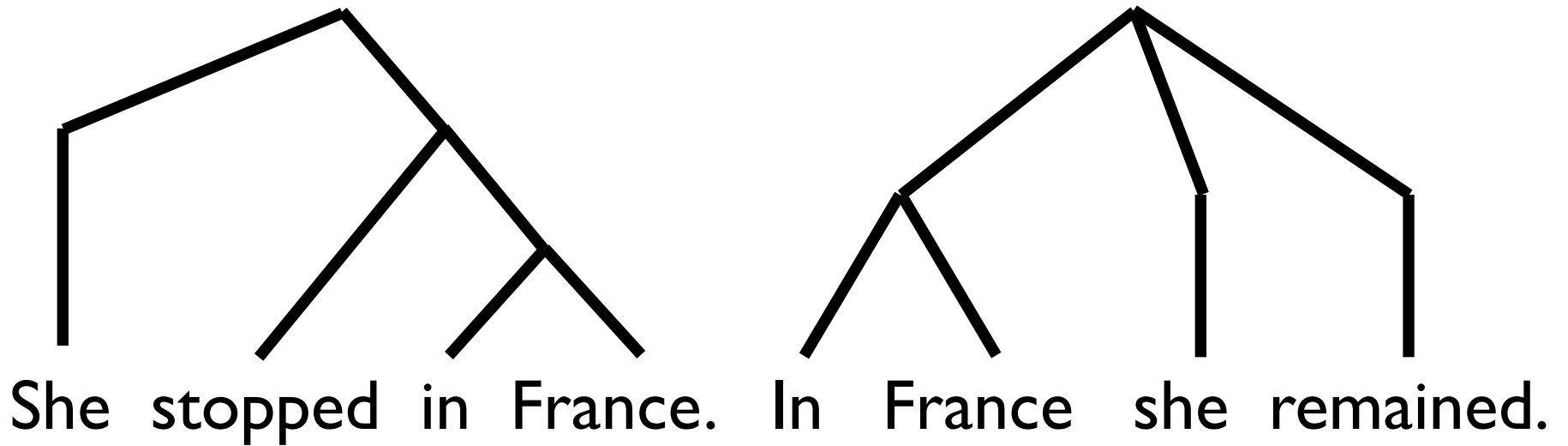

Joint Extractive / Compressive Model

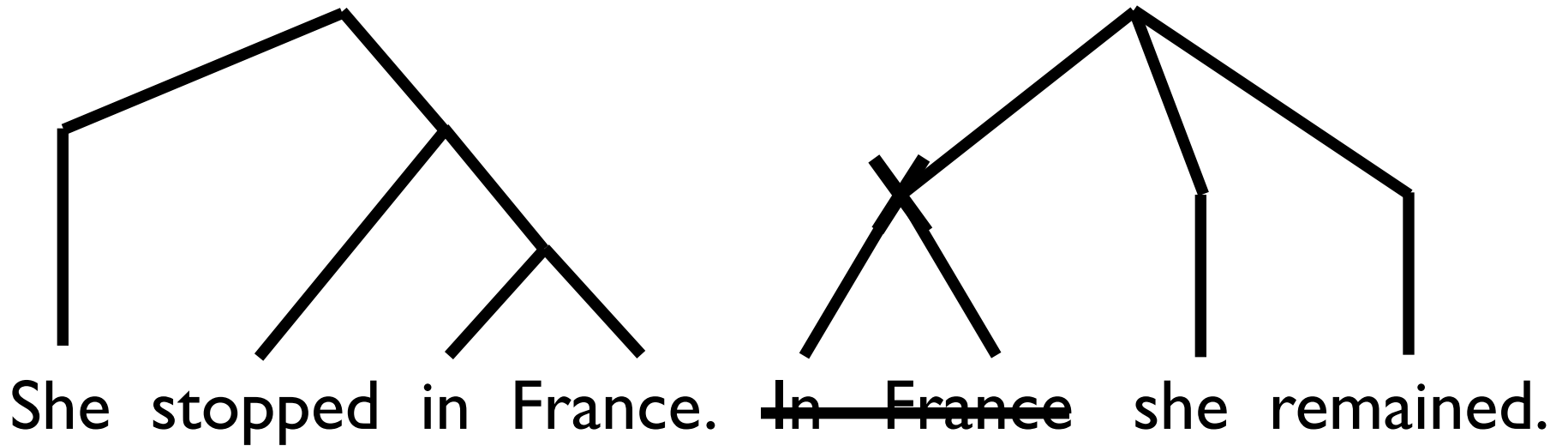

Joint Extractive / Compressive Model

S

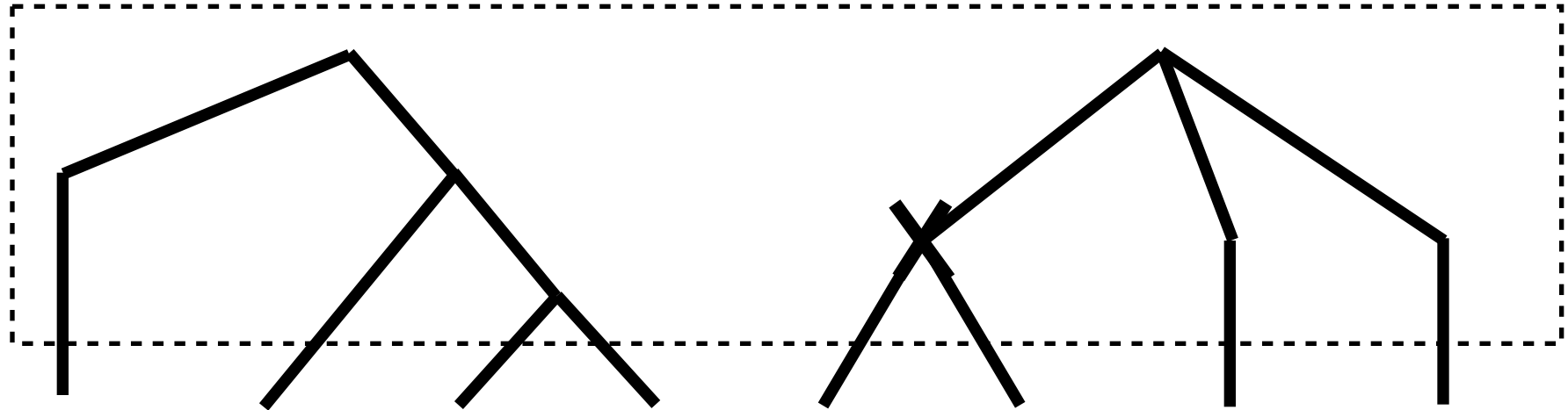

She stopped in France. ~~In France~~ she remained.

Joint Extractive / Compressive Model

S

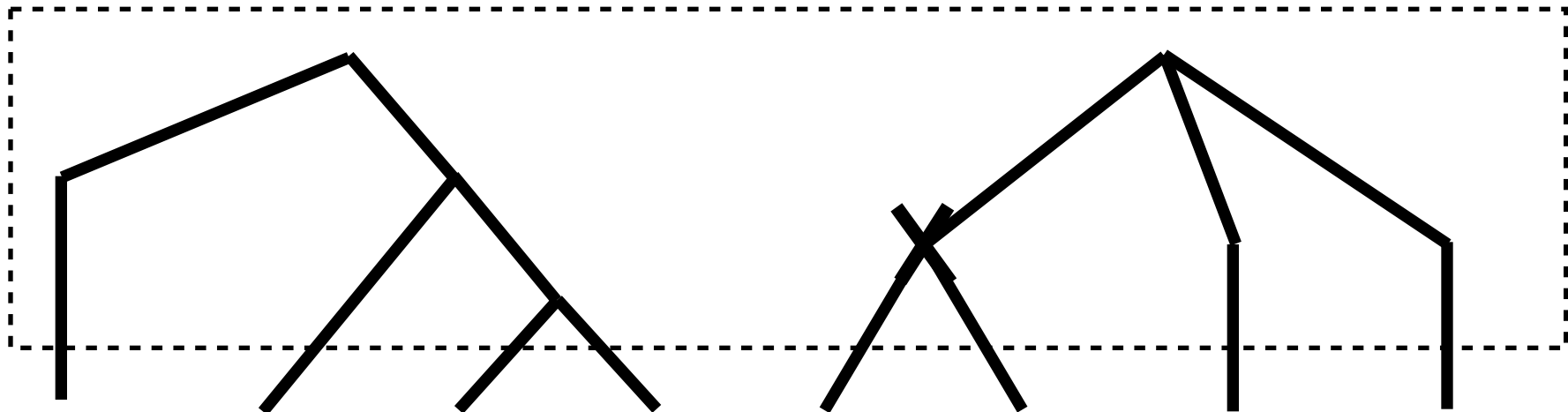

She stopped in France. ~~In France~~ she remained.

(she, stopped) ✓
(stopped, in) ✓

(in, france) ✓
(france, she) ✓

(she, remained) ✓

Joint Extractive / Compressive Model

S

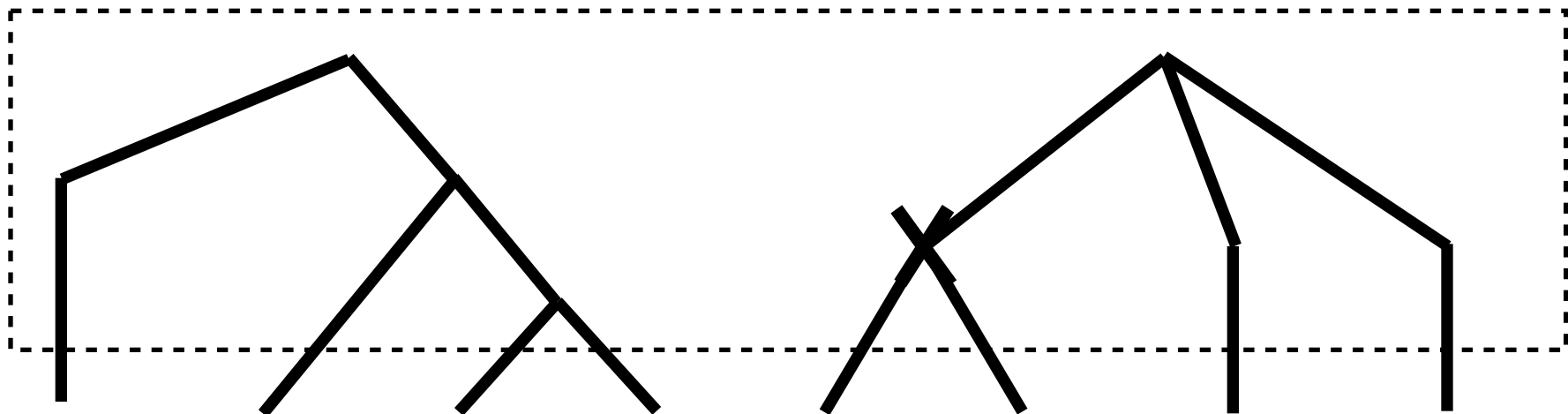

She stopped in France. ~~In France~~ she remained.

(she, stopped) ✓
(stopped, in) ✓

(in, france) ✓
(france, she) ✓

(she, remained) ✓

$B(s)$

Joint Extractive / Compressive Model

S

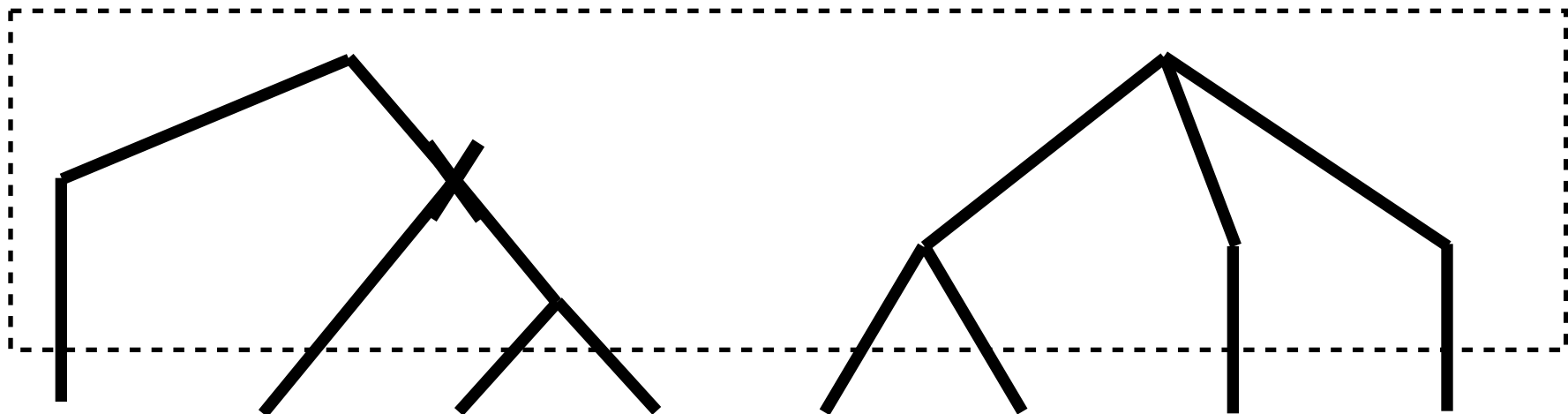

She ~~stopped in France.~~ In France she remained.

(she, stopped)

(stopped, in)

(in, france) ✓

(france, she) ✓

(she, remained) ✓

B(s)

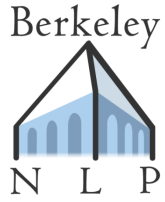

Joint Extractive / Compressive Model

$$\max_s \left[\sum_{b \in B(s)} \text{value}(b) \right]$$

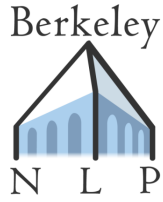

Joint Extractive / Compressive Model

$$\max_s \left[\sum_{b \in B(s)} \text{value}(b) + \sum_{c \in s} \text{value}(c) \right]$$



Joint Extractive / Compressive Model

$$\max_s \left[\sum_{b \in B(s)} \text{value}(b) + \sum_{c \in s} \text{value}(c) \right]$$

Parameterize using features:

$$\text{value}(b) = w^\top f(b)$$

$$\text{value}(c) = w^\top f(c)$$

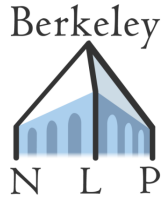

Learning

Linear prediction:

$$\text{score}(s) = w^\top f(s)$$

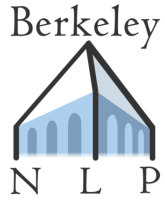

Learning

Linear prediction:

$$\text{score}(s) = w^\top f(s)$$

Feature function factors:

$$f(s) = \sum_{b \in B(s)} f(b) + \sum_{c \in s} f(c)$$

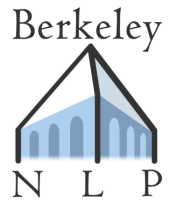

Features

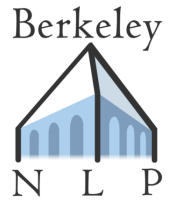

Features

Bigram Features $f(b)$

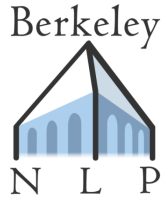

Features

Bigram Features $f(b)$

Cut Features $f(c)$



Features

Bigram Features $f(b)$

Cut Features $f(c)$

COUNT: Bucketed document counts

STOP: Stop word indicators

POSITION: First document position indicators

CONJ: All two- and three-way conjunctions of above

BIAS: Always one



Features

Bigram Features $f(b)$

COUNT:	Bucketed document counts
STOP:	Stop word indicators
POSITION:	First document position indicators
CONJ:	All two- and three-way conjunctions of above
BIAS:	Always one

Cut Features $f(c)$

COORD:	Coordinated phrase, four versions: NP, VP, S, SBAR
S-ADJUNCT:	Adjunct to matrix verb, four versions: CC, PP, ADVP, SBAR
REL-C:	Relative clause indicator
ATTR-C:	Attribution clause indicator
ATTR-PP:	PP attribution indicator
TEMP-PP:	Temporal PP indicator
TEMP-NP	Temporal NP indicator
BIAS:	Always one

Obtaining Training Data



Lindsay Lohan pleaded not guilty ~~Wednesday~~ to felony grand theft of a 2,500 necklace, ~~a case that could return the troubled starlet to jail rather than the big screen.~~ Saying it appeared that Lohan had violated her probation in a 2007 drunken driving case the judge set bail at \$40,000 ~~and warned that if Lohan was accused of breaking the law while free he would have her held without bail.~~ The Mean Girls star is due back in court on Feb. 23 ~~an important hearing in which Lohan could opt to end the case early.~~

Obtaining Training Data

TAC 2009: 44 Document Collections

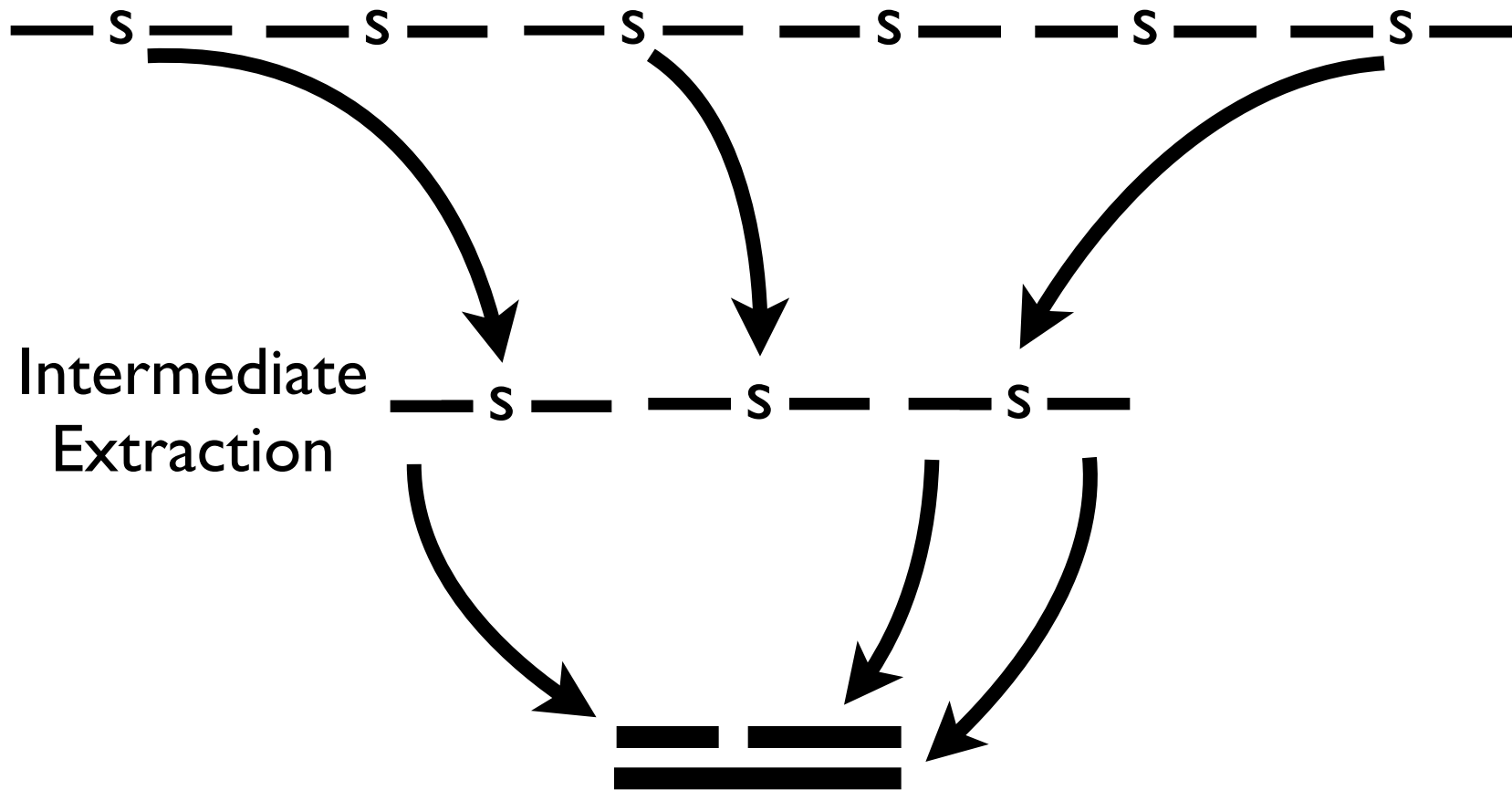

Obtaining Training Data

TAC 2009: 44 Document Collections

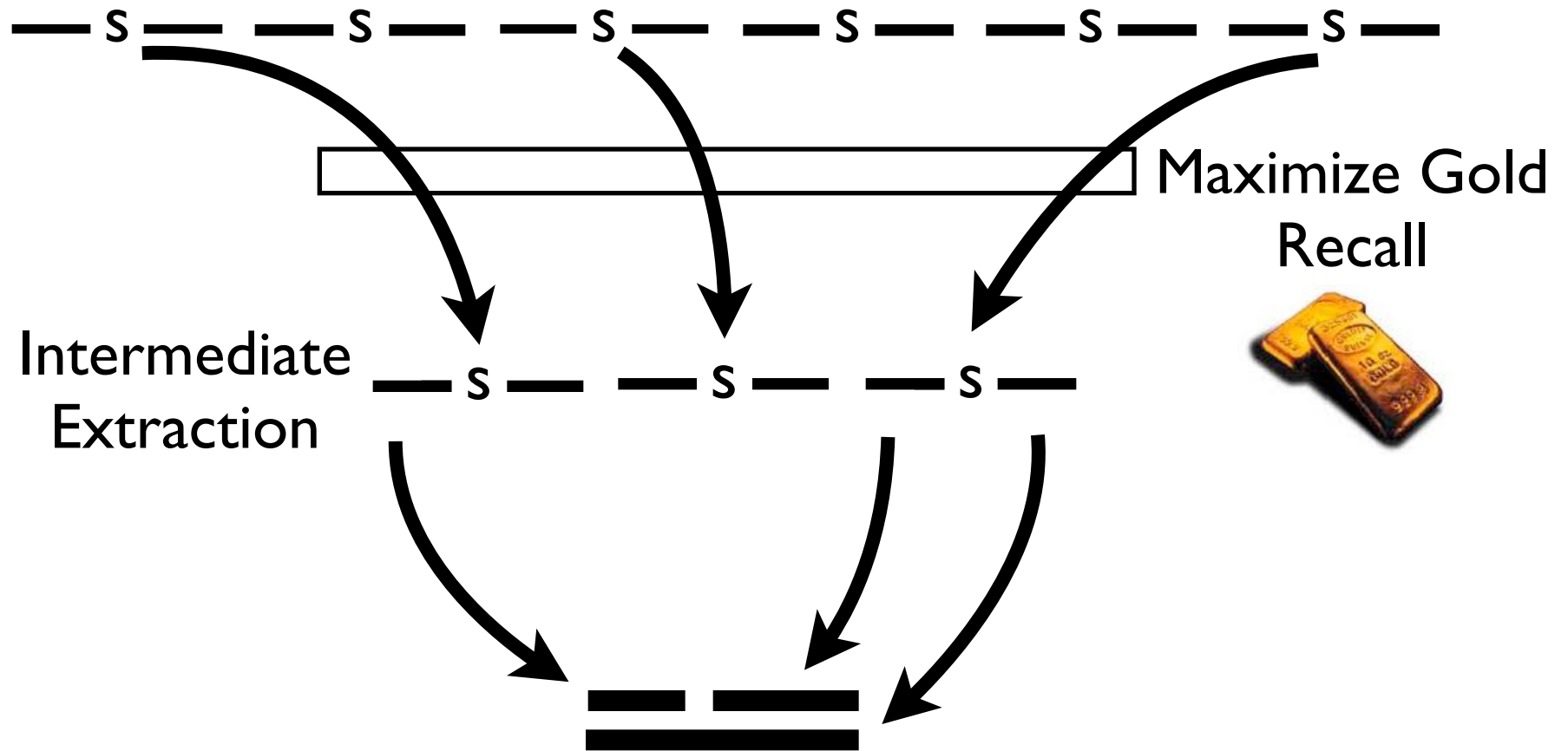

Obtaining Training Data

TAC 2009: 44 Document Collections

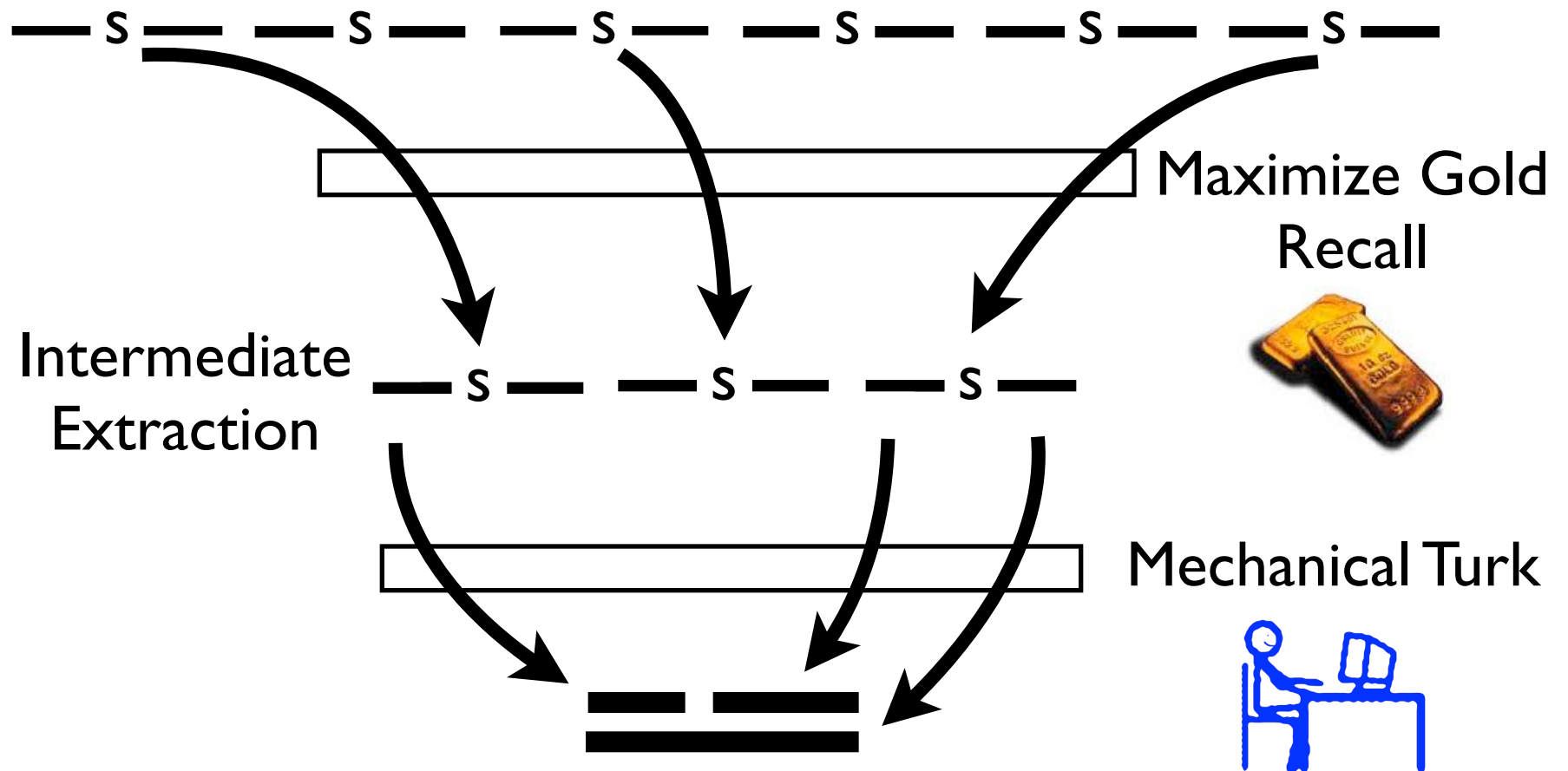

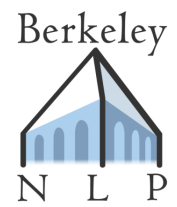

Learning

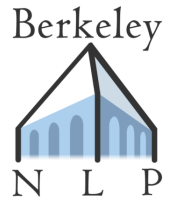

Learning

Structured SVM Training:



Learning

Structured SVM Training:

$$\min_w \quad \|w\|_2^2$$

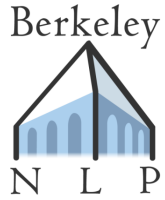

Learning

Structured SVM Training:

$$\min_w \quad \|w\|_2^2$$

s.t. for all possible guess summaries:

score of gold exceeds score of guess by loss

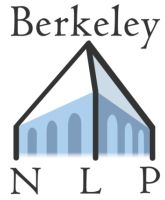

Learning

Structured SVM Training:

$$\min_w \quad \|w\|_2^2$$

s.t. for all possible guess summaries:

$$w^\top f(S^*) - w^\top f(S) \geq \text{loss}(S^*, S)$$

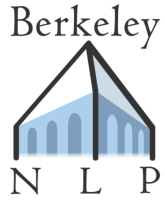

Learning

Structured SVM Training:

$$\min_w \quad \|w\|_2^2$$

s.t. for all possible guess summaries:

$$w^\top f(S^*) - w^\top f(S) \geq \text{loss}(S^*, S) - \xi$$

Learning

Structured SVM Training:

$$\min_w \left[\|w\|_2^2 + \xi \right]$$

s.t. for all possible guess summaries:

$$w^\top f(S^*) - w^\top f(S) \geq \text{loss}(S^*, S) - \xi$$

Learning

Structured SVM Training:

$$\min_w \left[\|w\|_2^2 + \xi \right]$$

s.t. for all possible guess summaries:

$$w^\top f(S^*) - w^\top f(S) \geq \boxed{\text{loss}(S^*, S)} - \xi$$

End-to-end summarization
 quality

Learning

Structured SVM Training:

$$\min_w \left[\|w\|_2^2 + \xi \right]$$

s.t. for all possible guess summaries:

$$w^\top f(S^*) - w^\top f(S) \geq \text{loss}(S^*, S) - \xi$$

Exponentially many constraints!

Learning

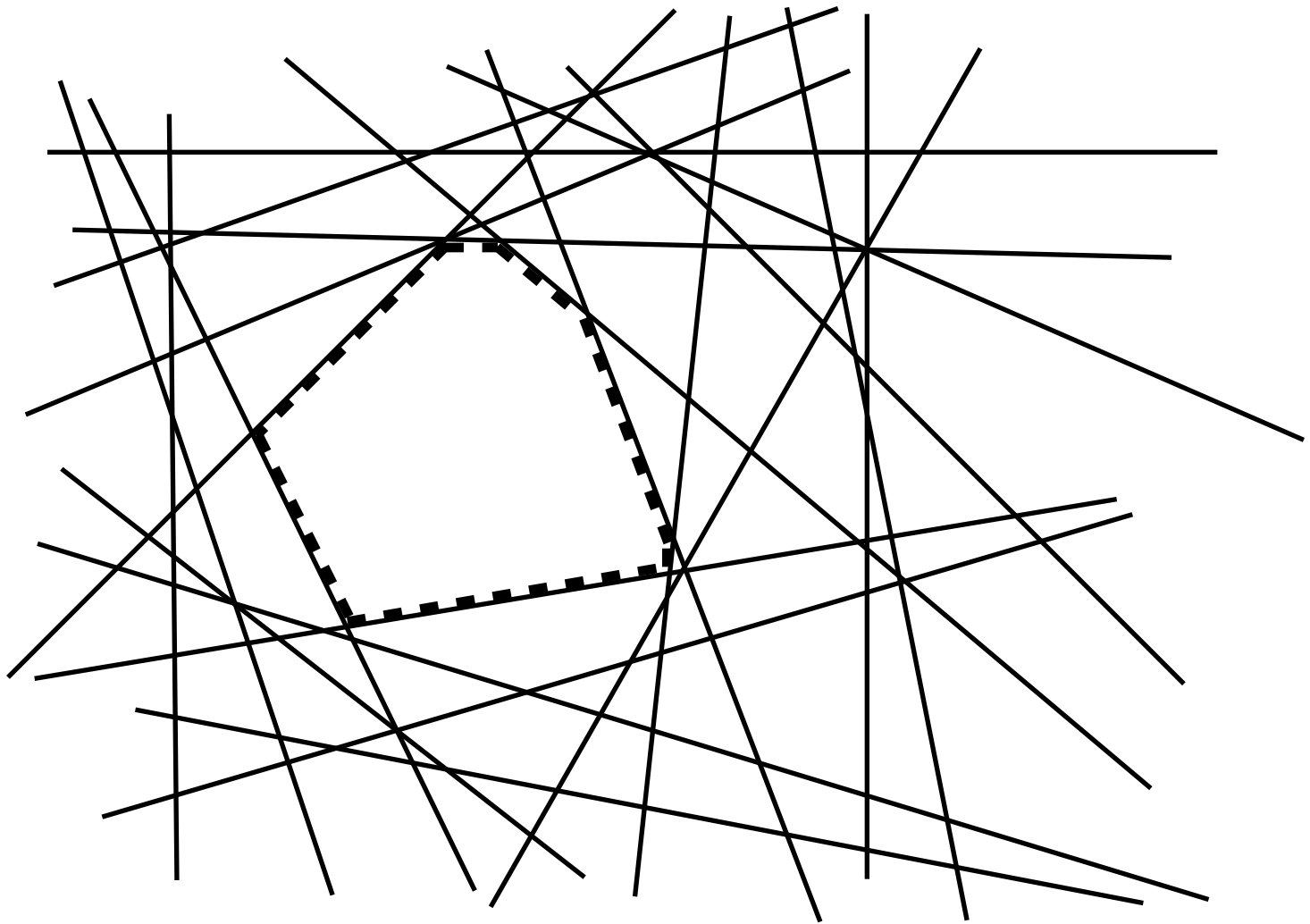

Learning

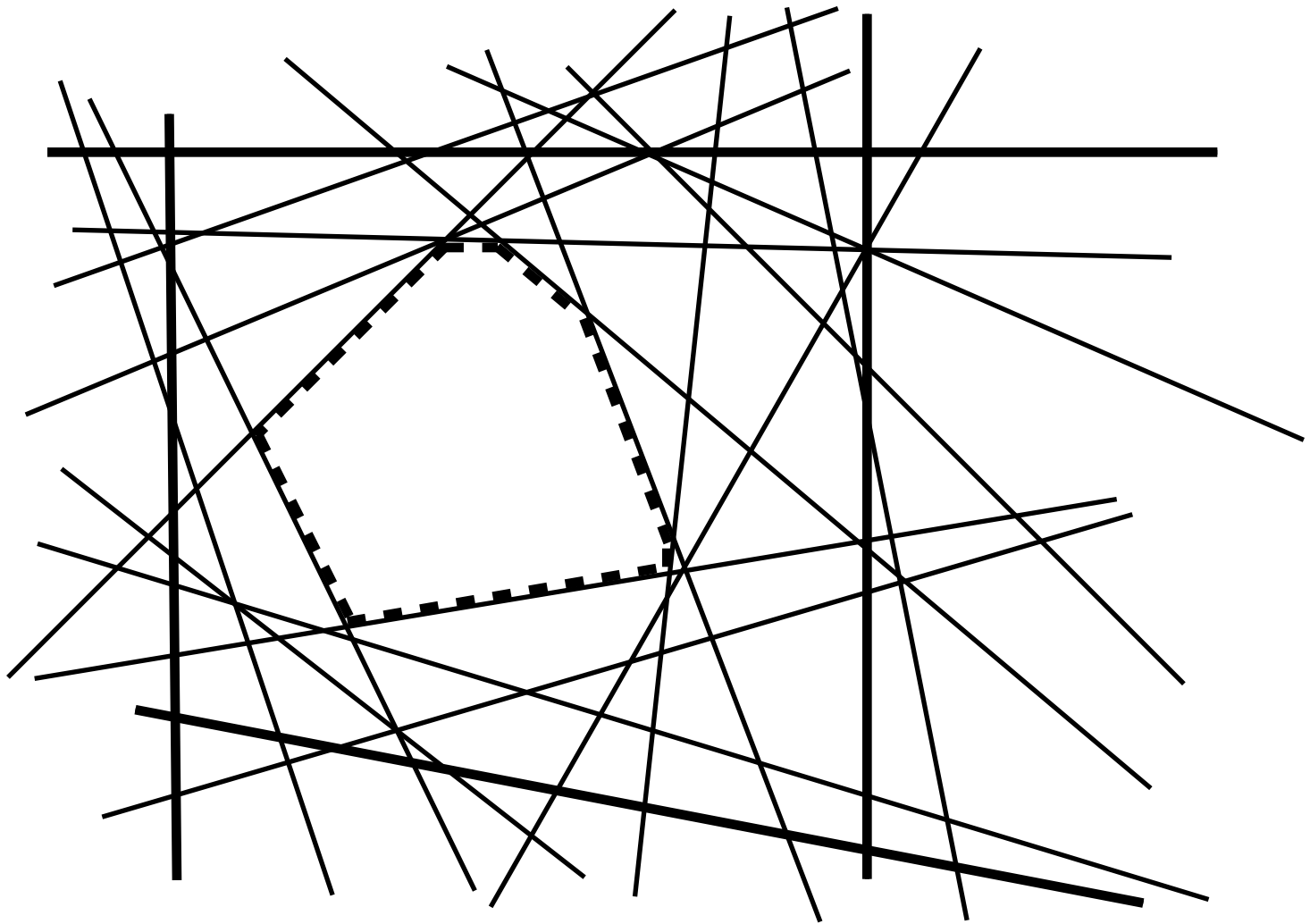

Learning

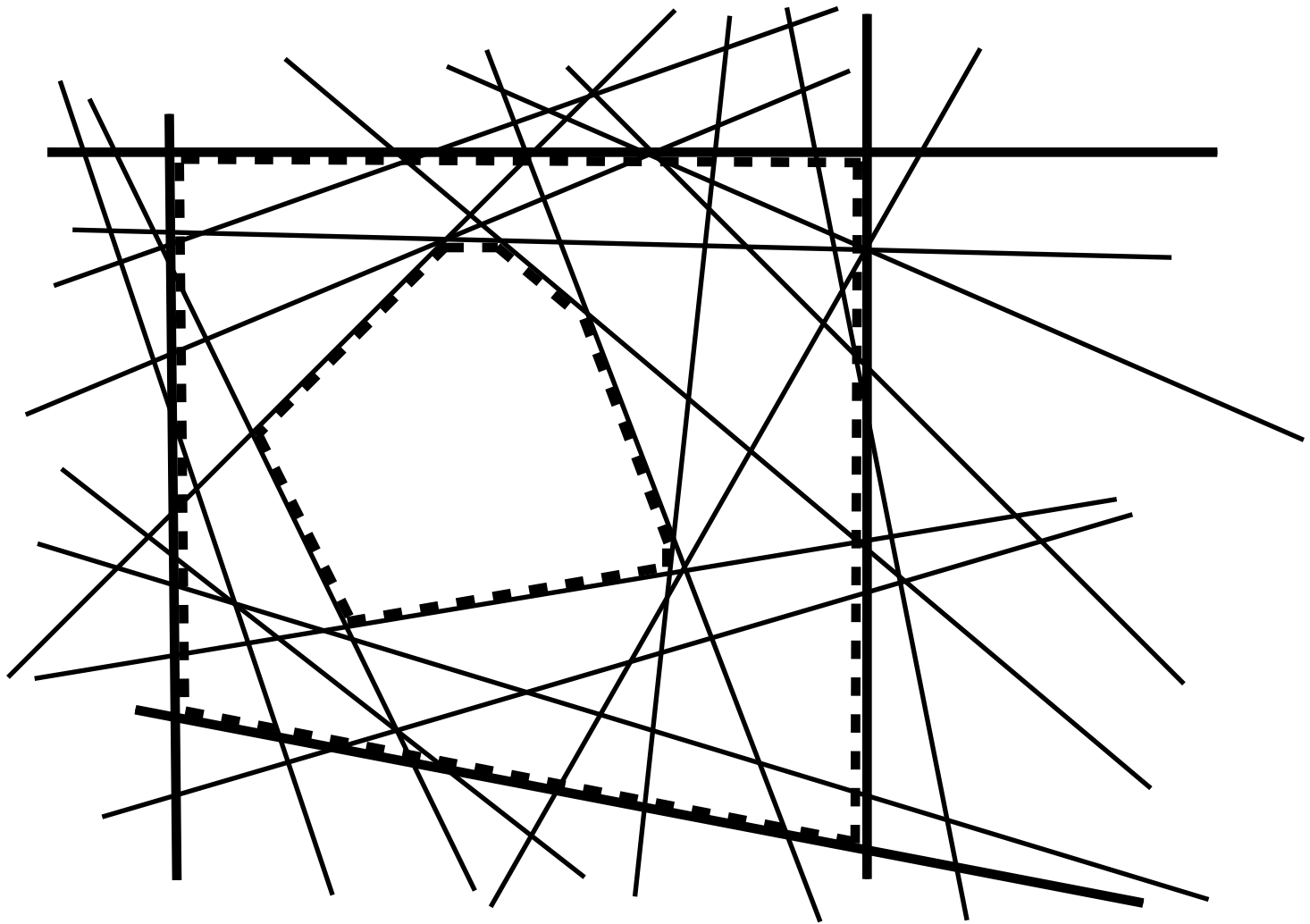

Learning

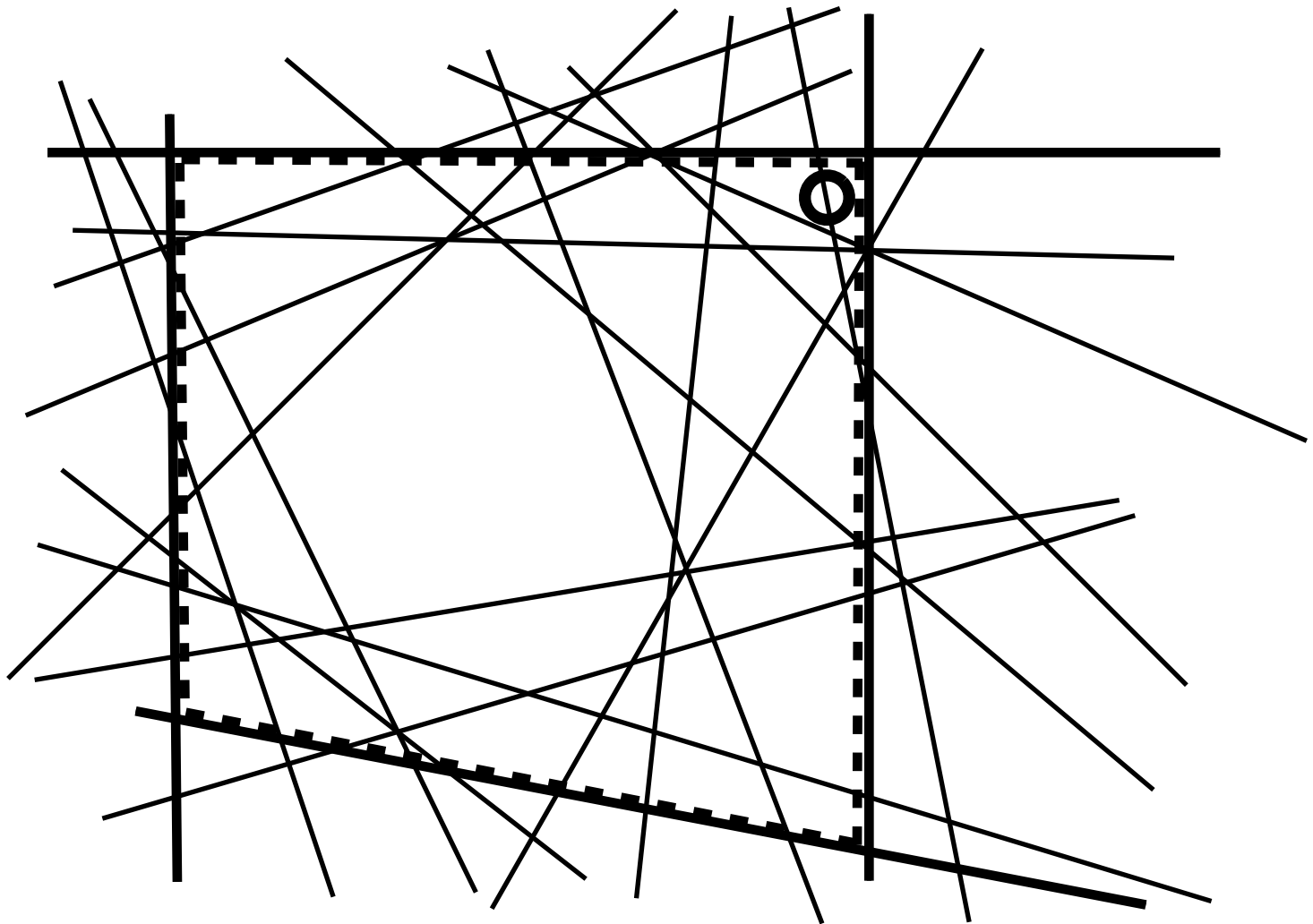

Learning

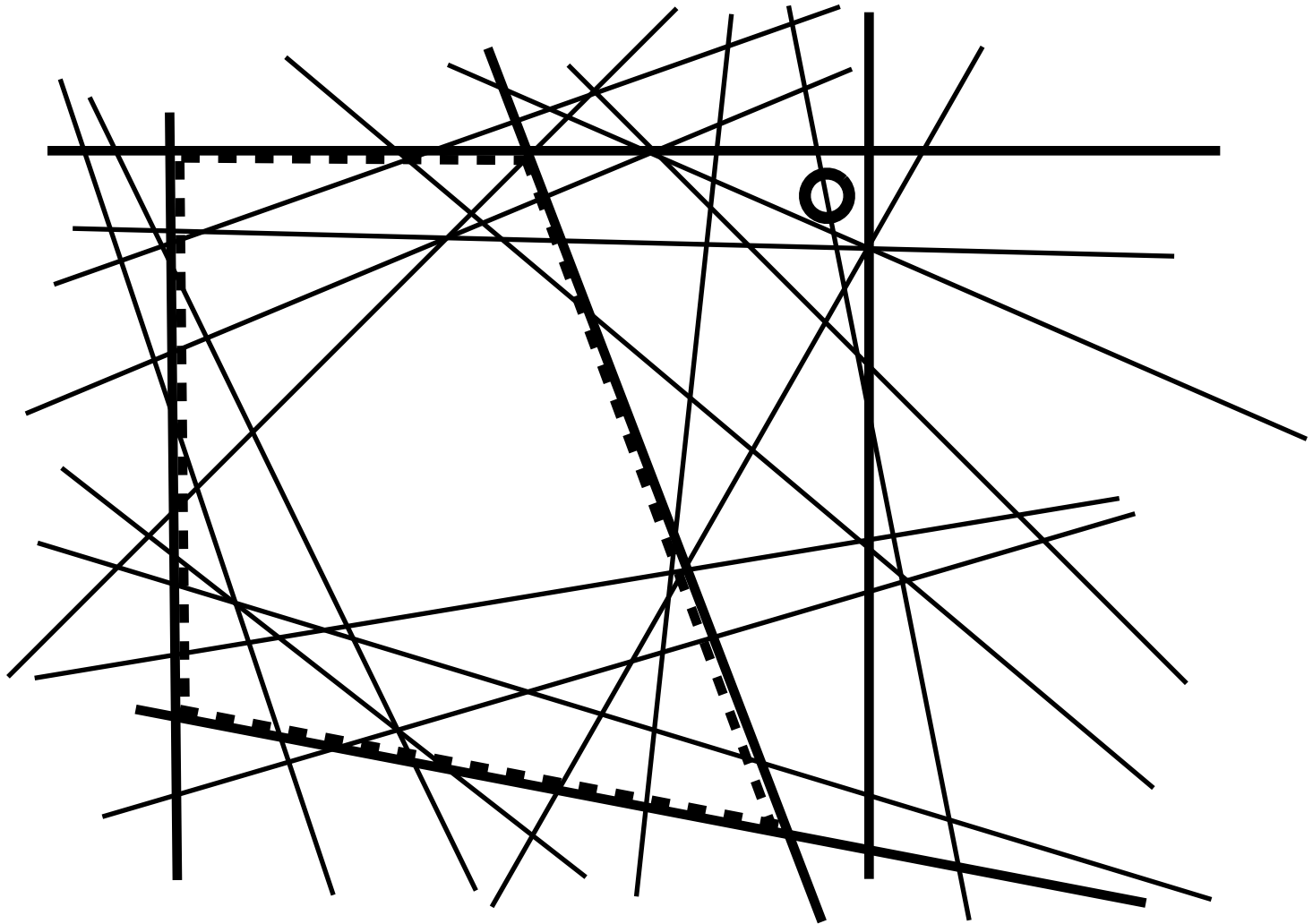

Learning

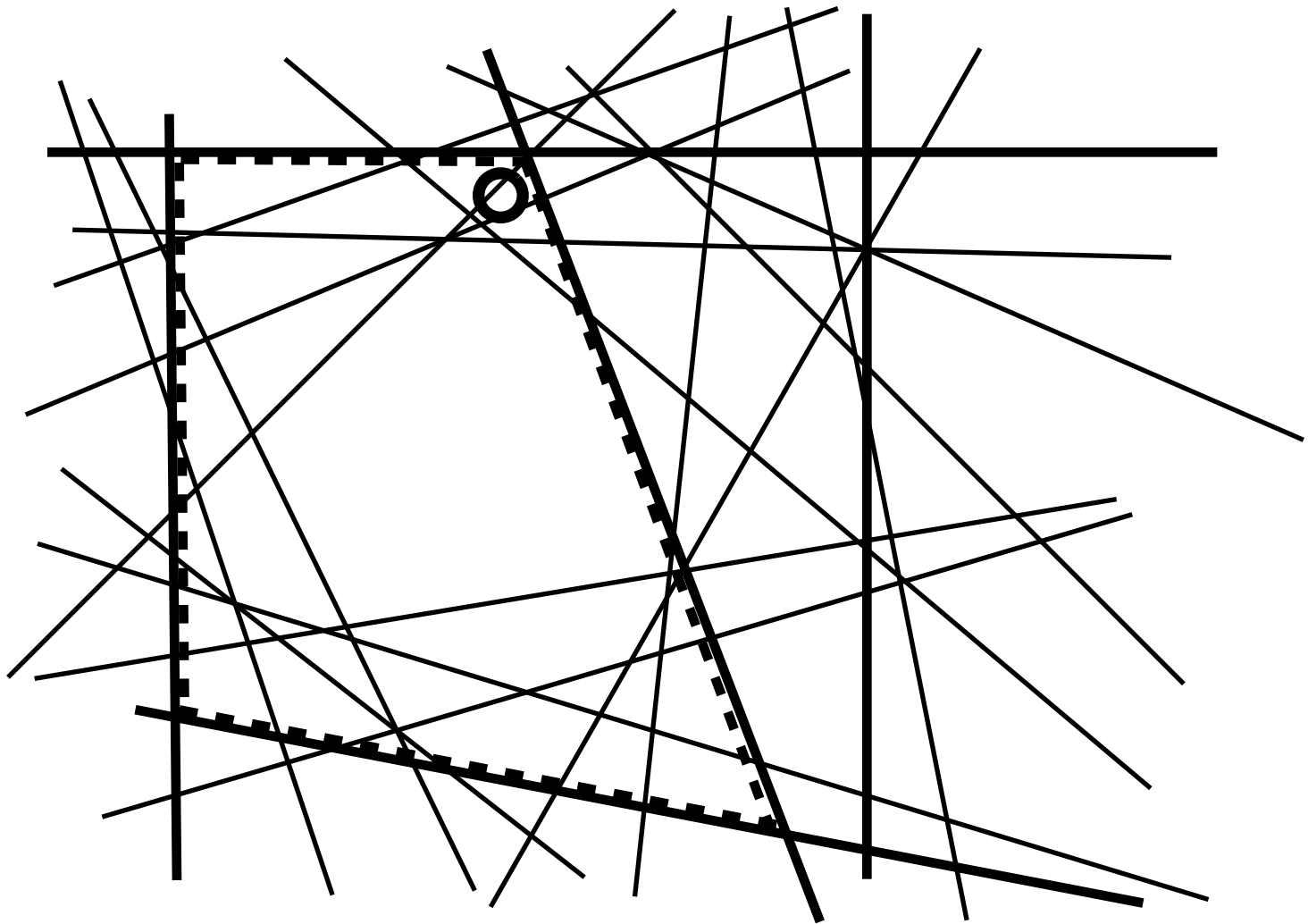

Learning

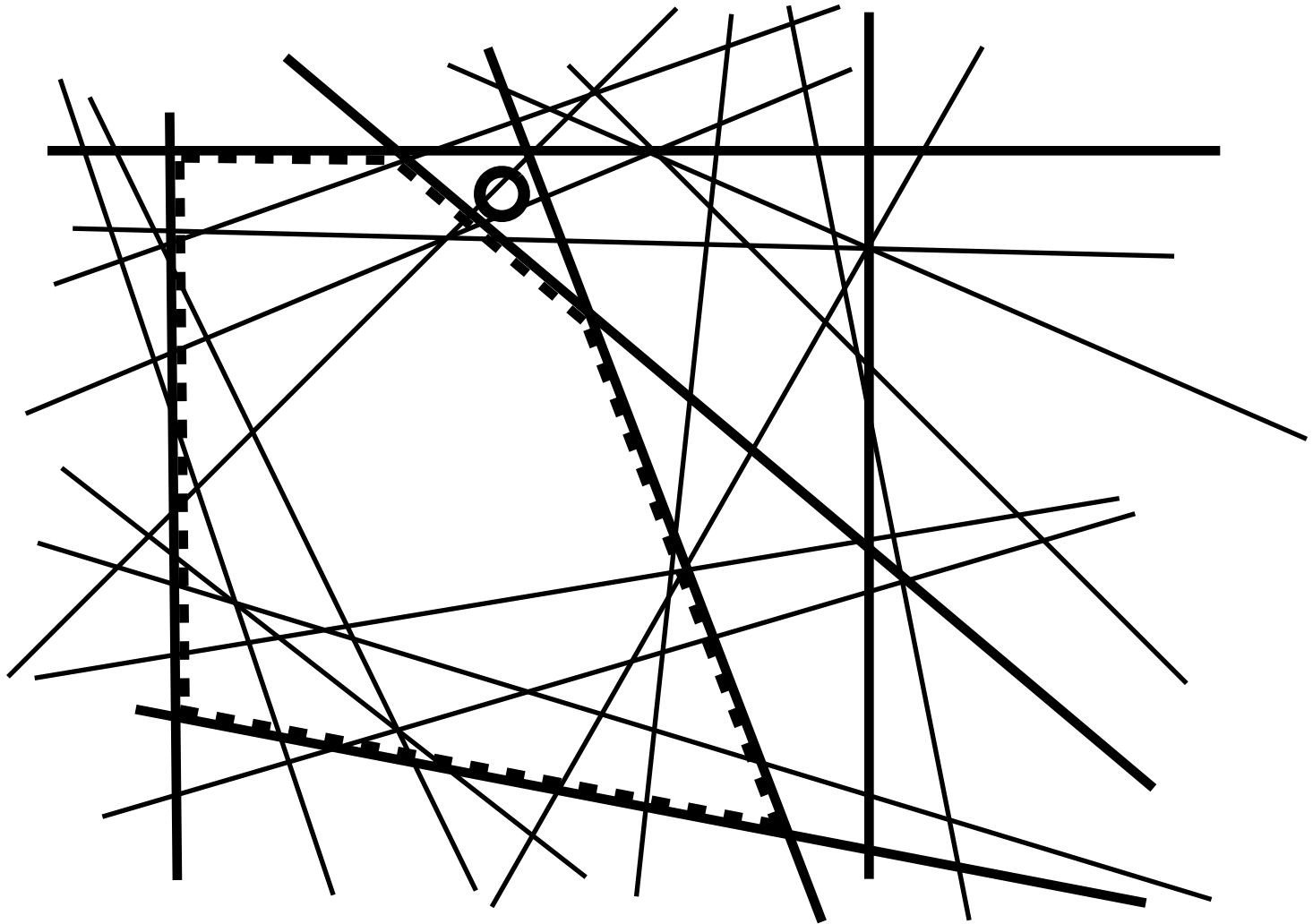

Learning

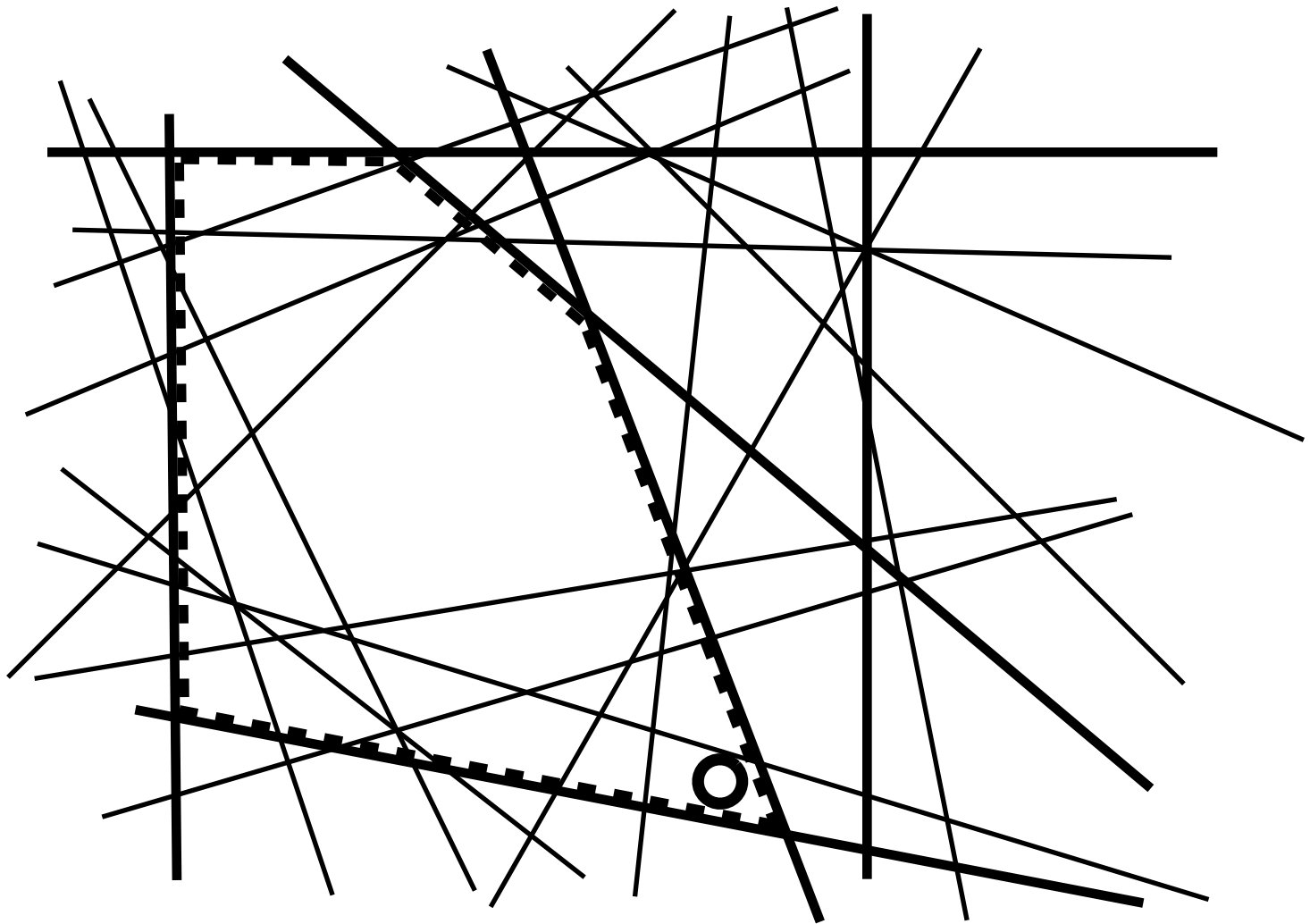

Learning

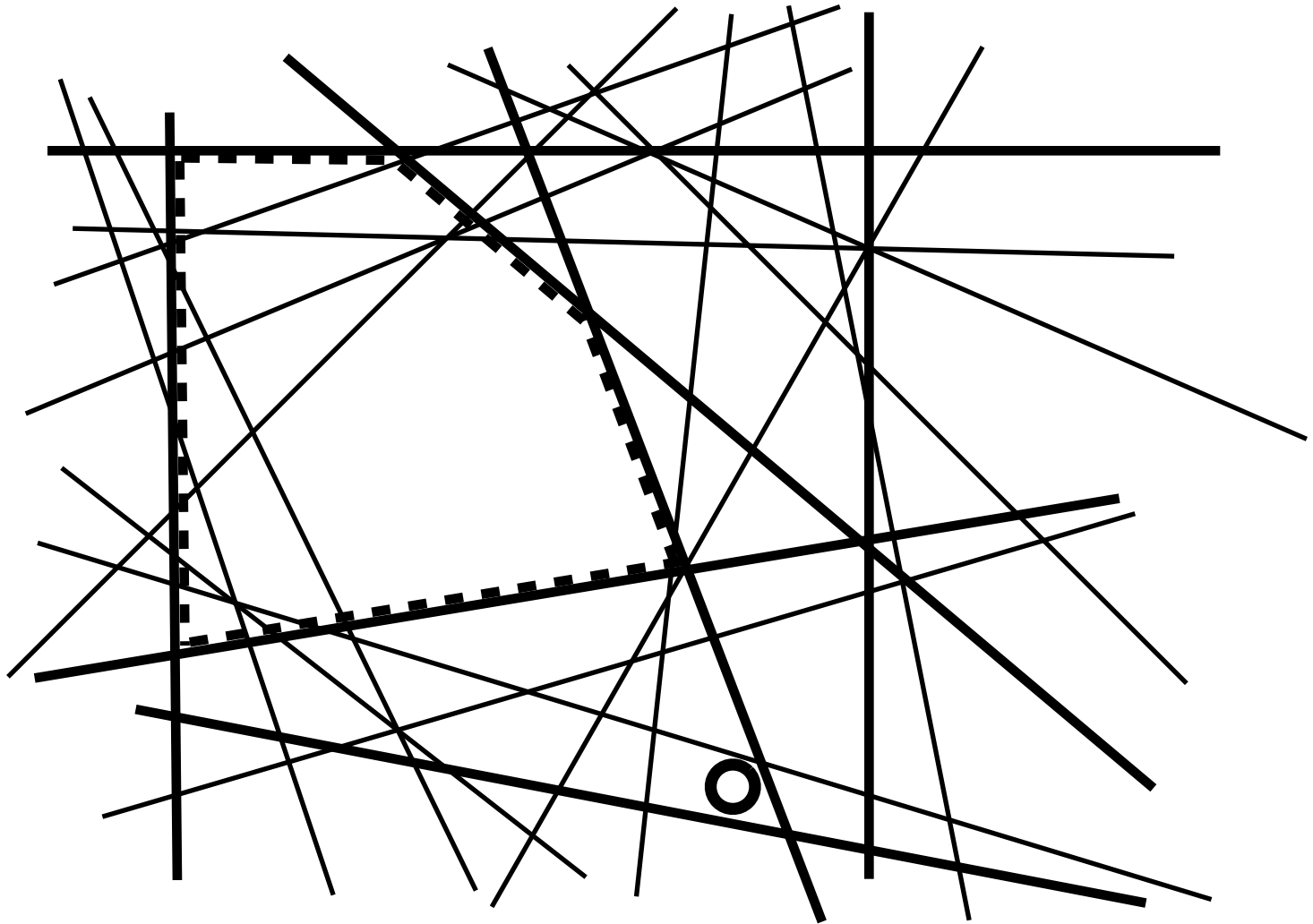

Learning

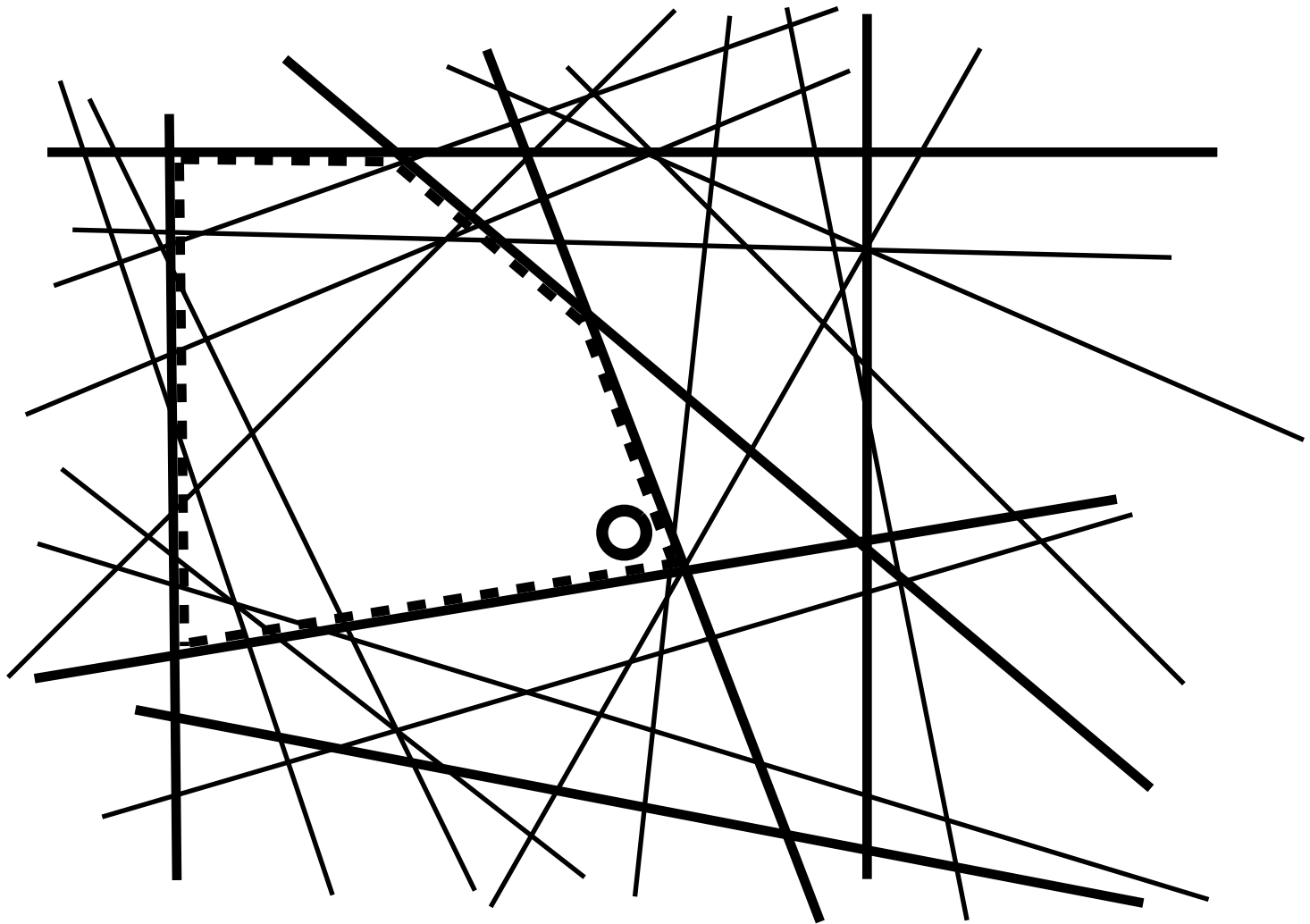

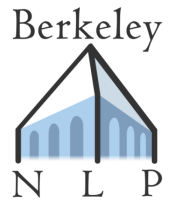

Results

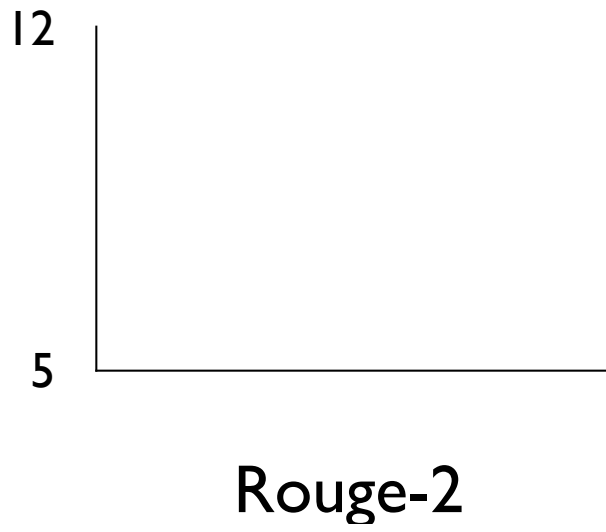

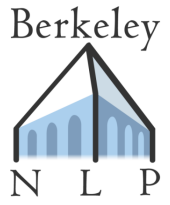

Results

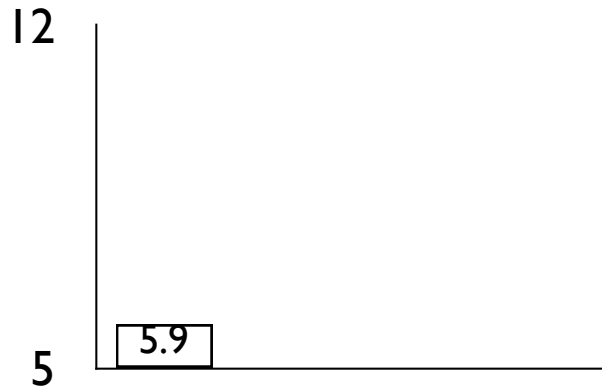

Rouge-2

Last Doc Baseline

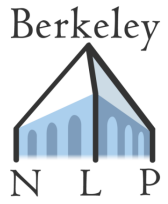

Results

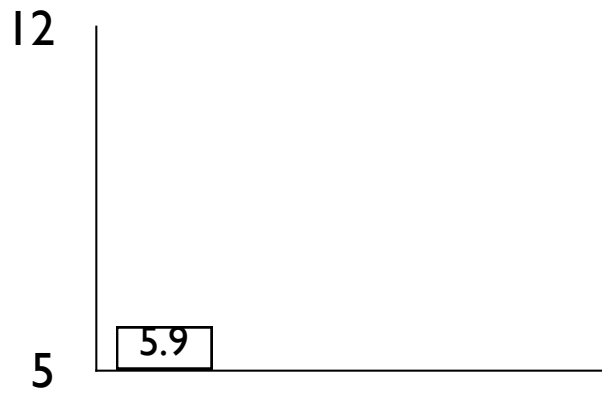

Rouge-2

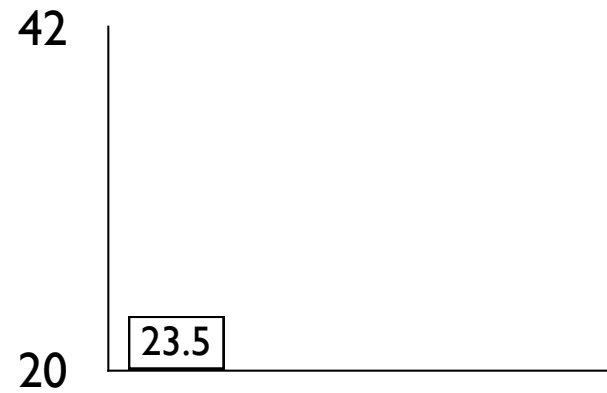

Pyramid

□ Last Doc Baseline

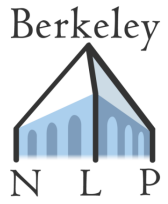

Results

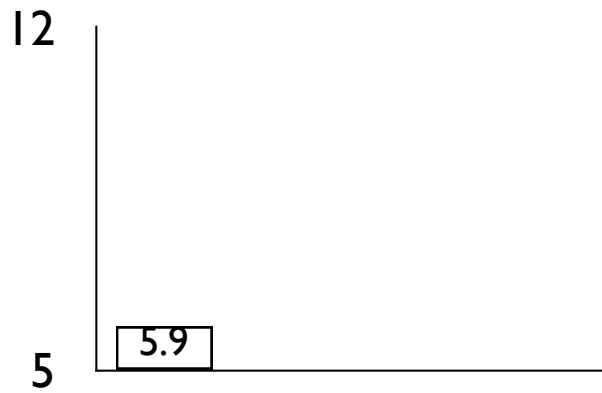

Rouge-2

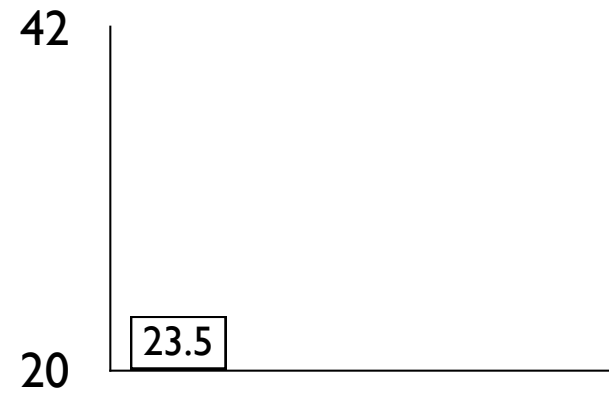

Pyramid

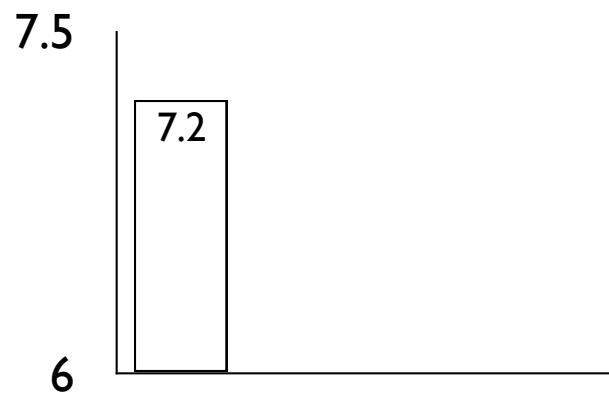

Linguistic Quality

□ Last Doc Baseline

Results

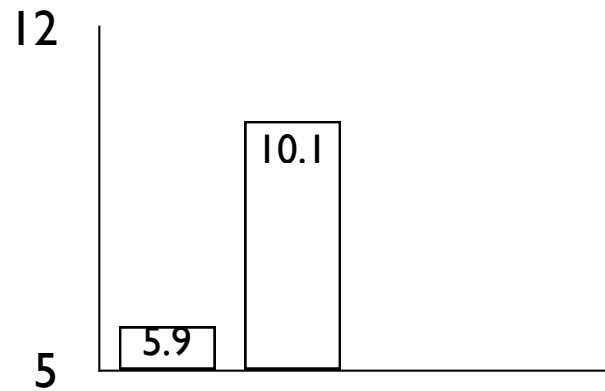

Rouge-2

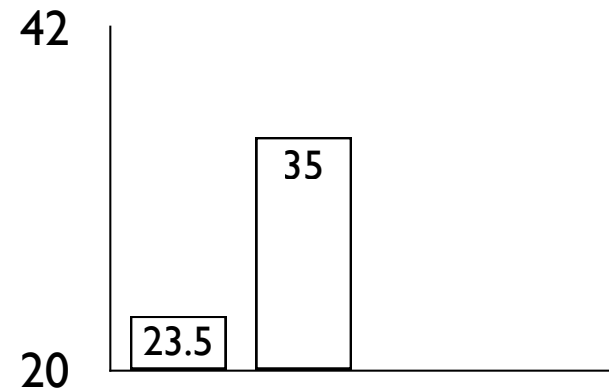

Pyramid

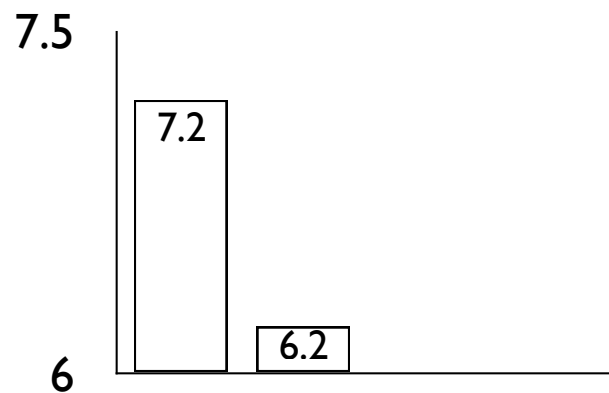

Linguistic Quality

- Last Doc Baseline
- Extractive Baseline

Results

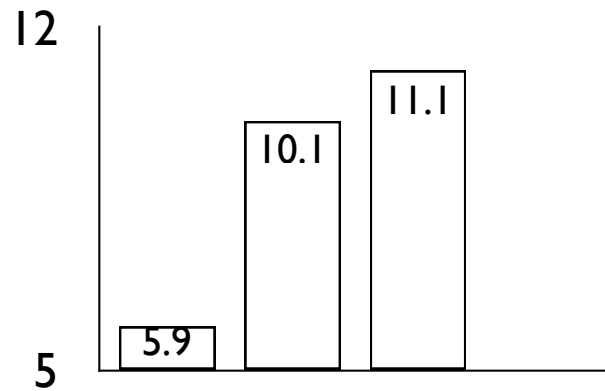

Rouge-2

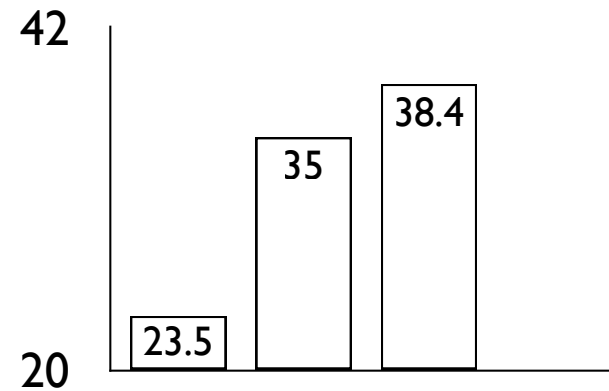

Pyramid

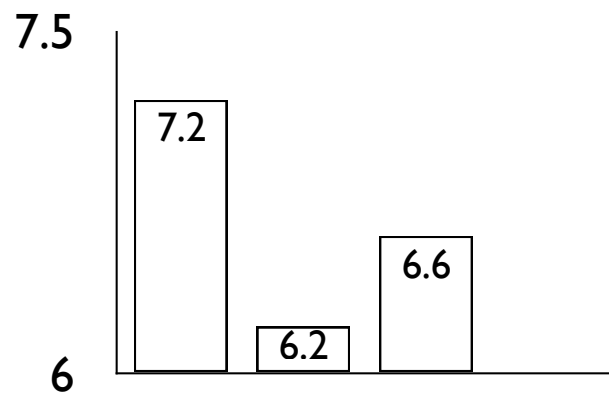

Linguistic Quality

- Last Doc Baseline
- Extractive Baseline
- Learned Extractive

Results

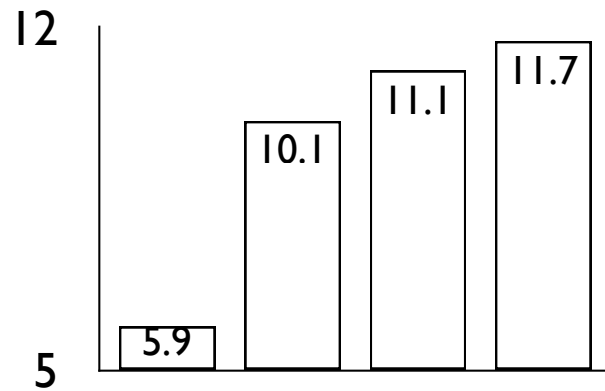

Rouge-2

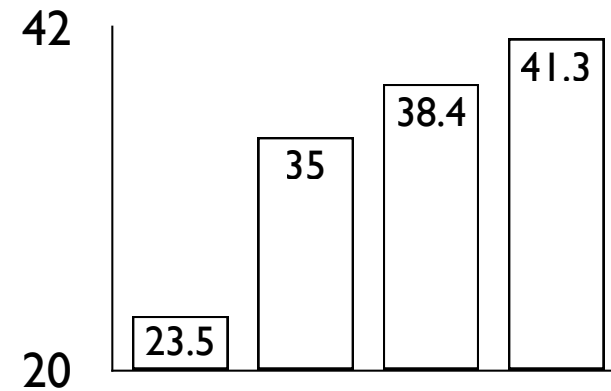

Pyramid

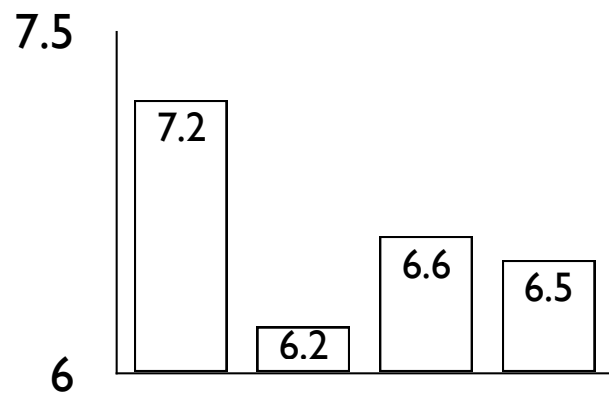

Linguistic Quality

- Last Doc Baseline
- Extractive Baseline
- Learned Extractive
- Learned E + C

Coarse-to-fine Decoding

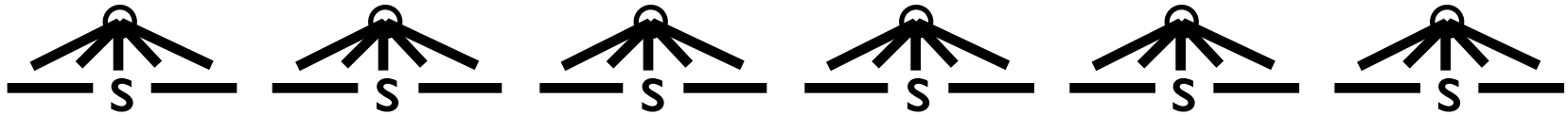

Coarse-to-fine Decoding

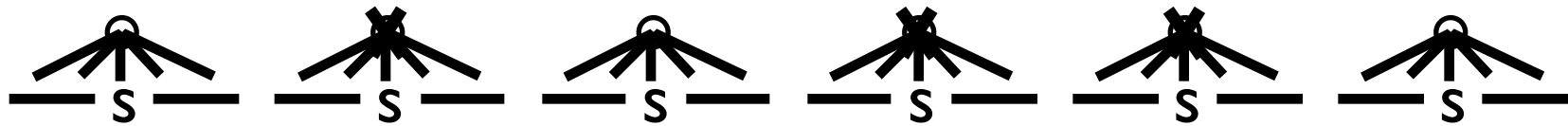

Coarse-to-fine Decoding

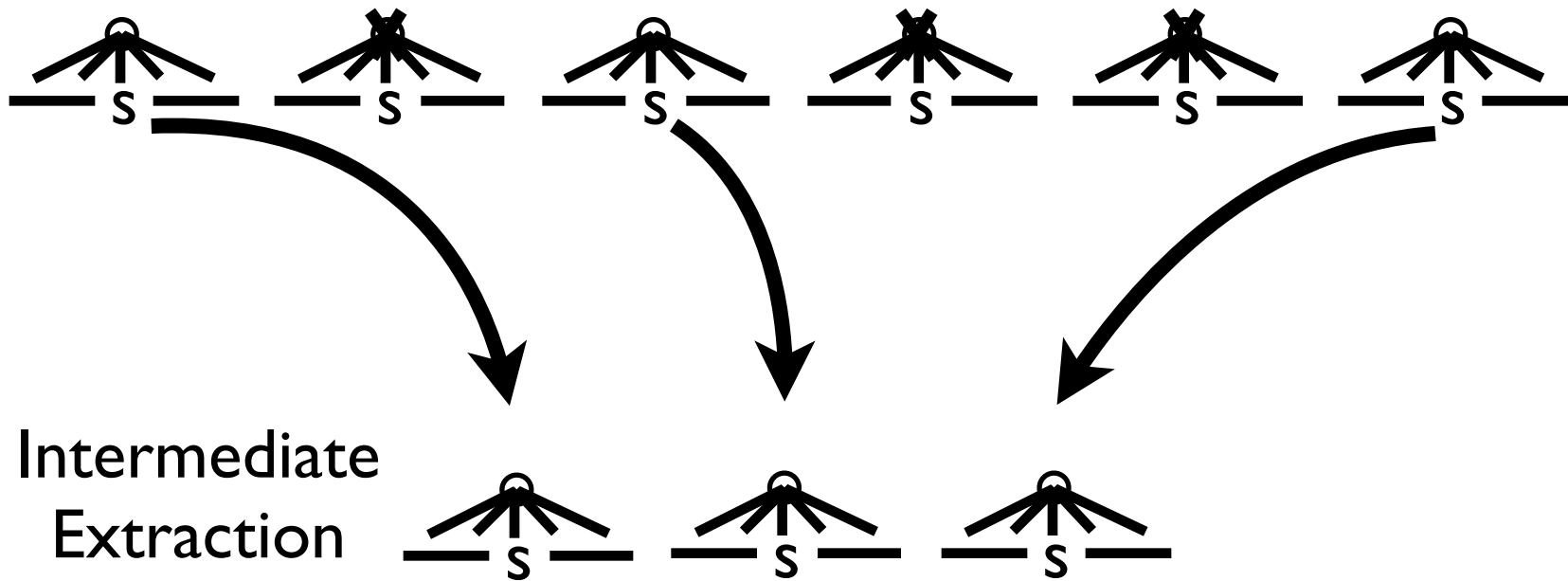

Coarse-to-fine Decoding

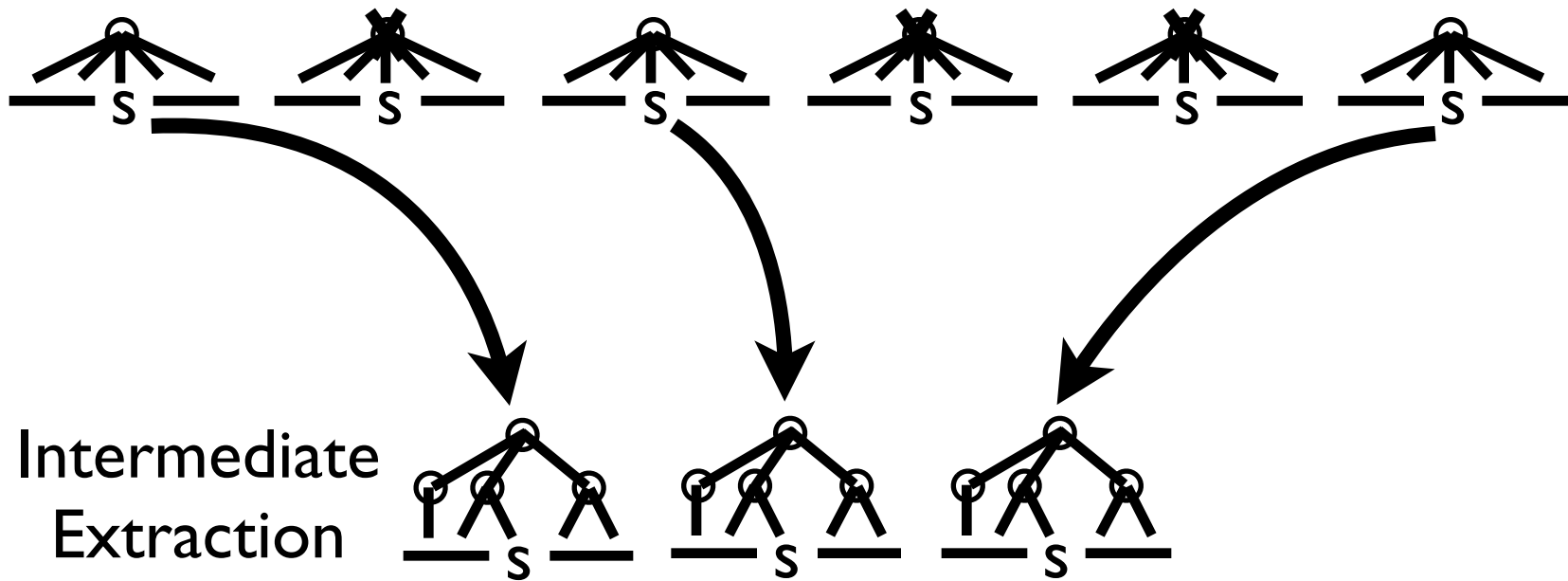

Coarse-to-fine Decoding

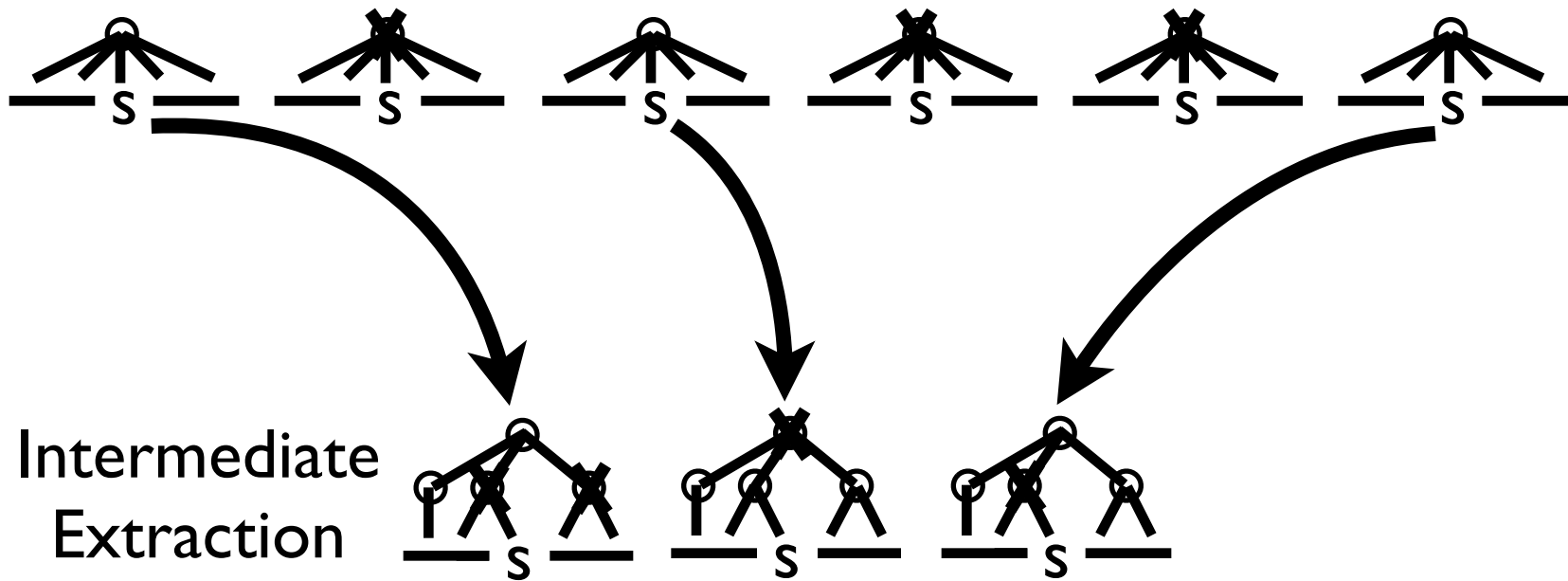

Coarse-to-fine Decoding

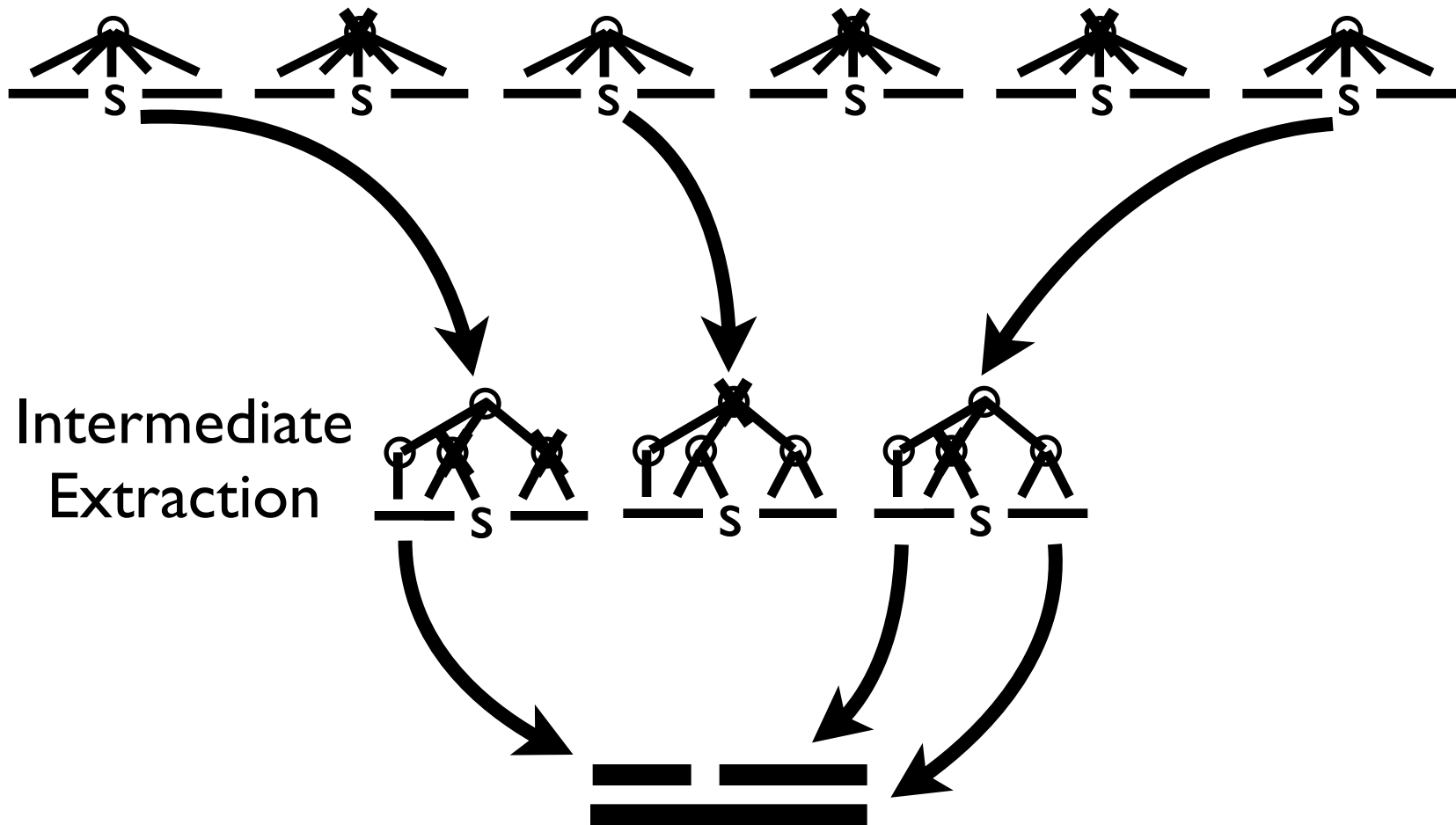

Coarse-to-fine Decoding

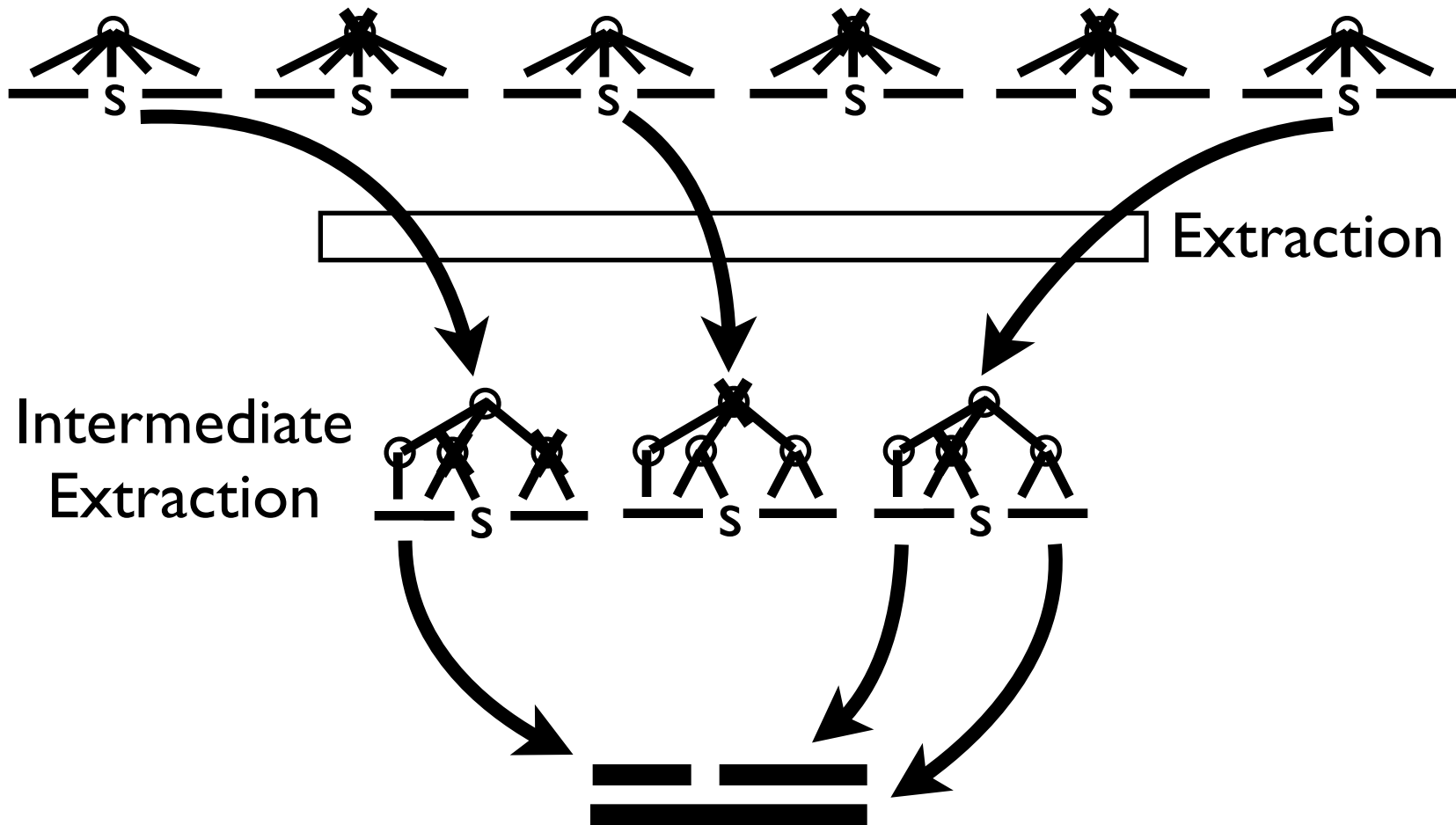

Coarse-to-fine Decoding

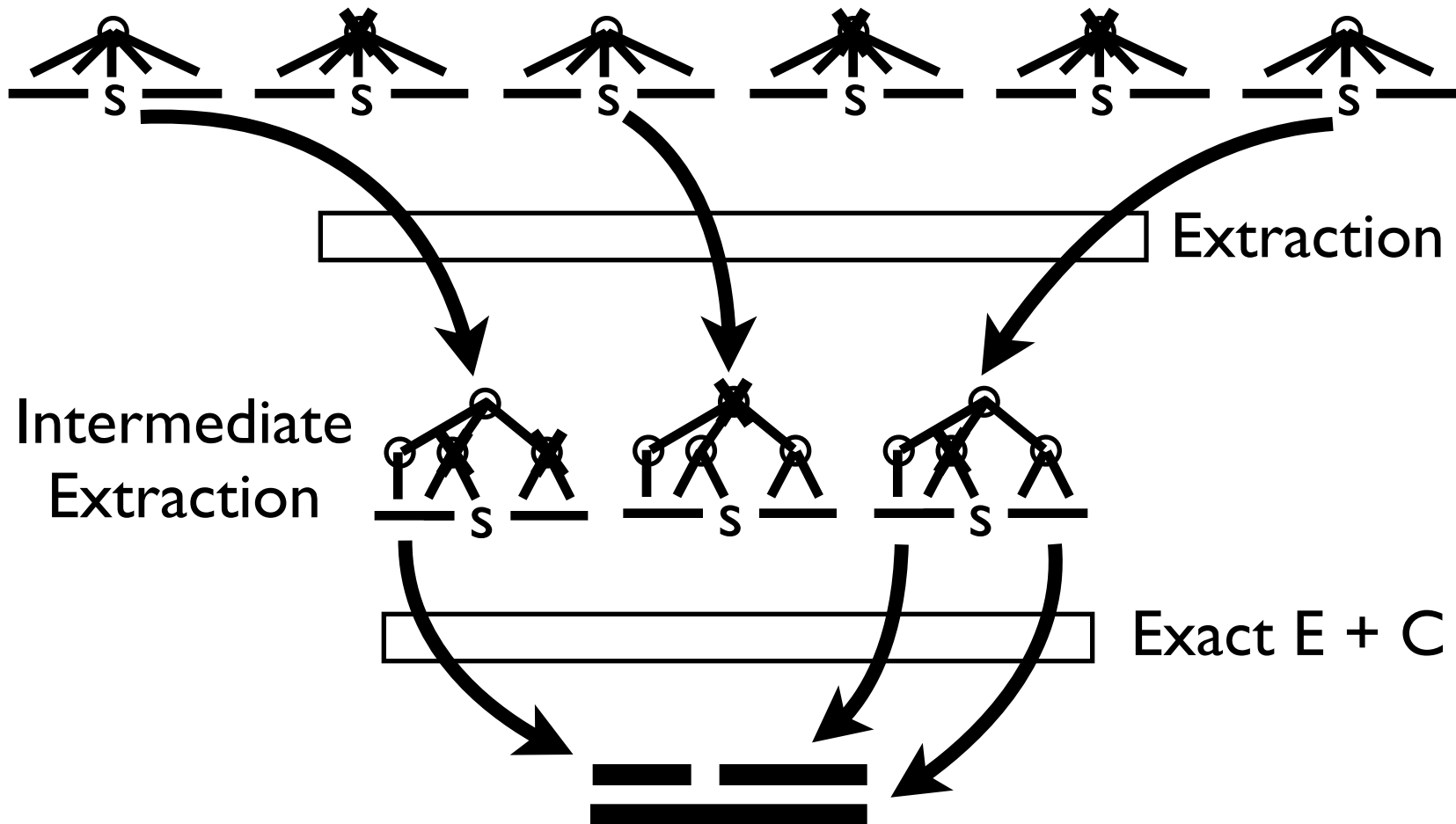

Coarse-to-fine Decoding

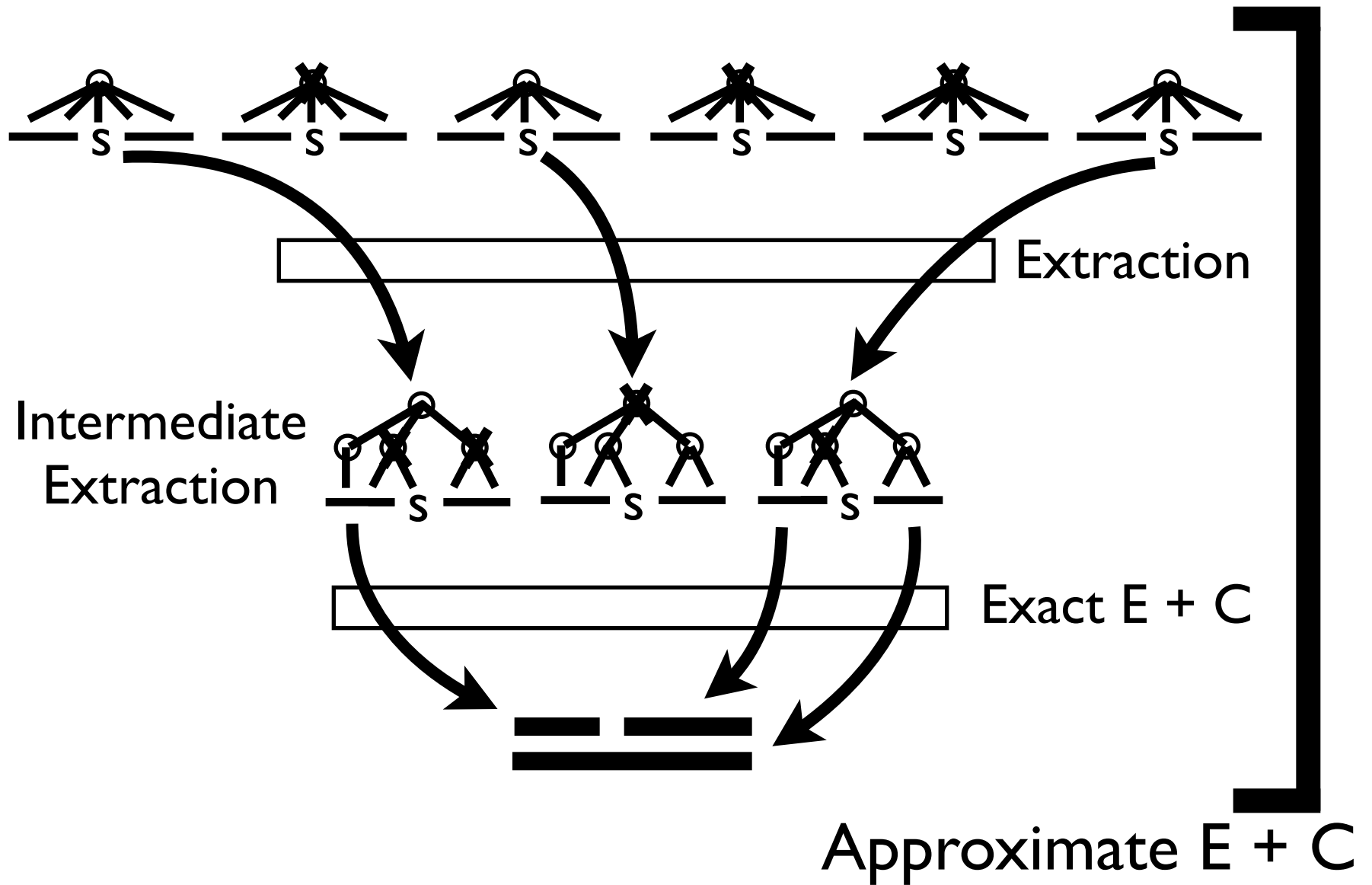



Coarse-to-fine Decoding

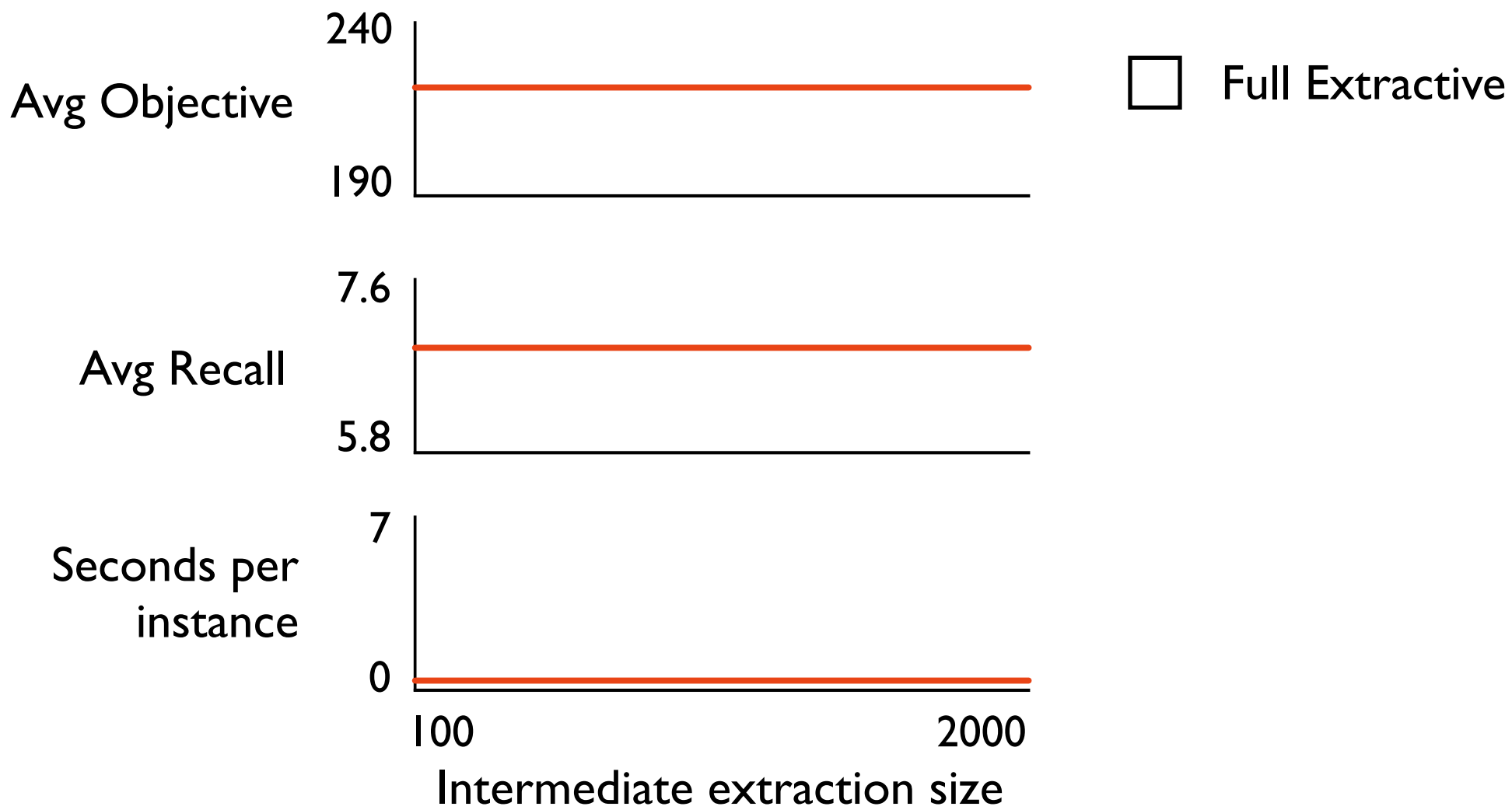

Coarse-to-fine Decoding

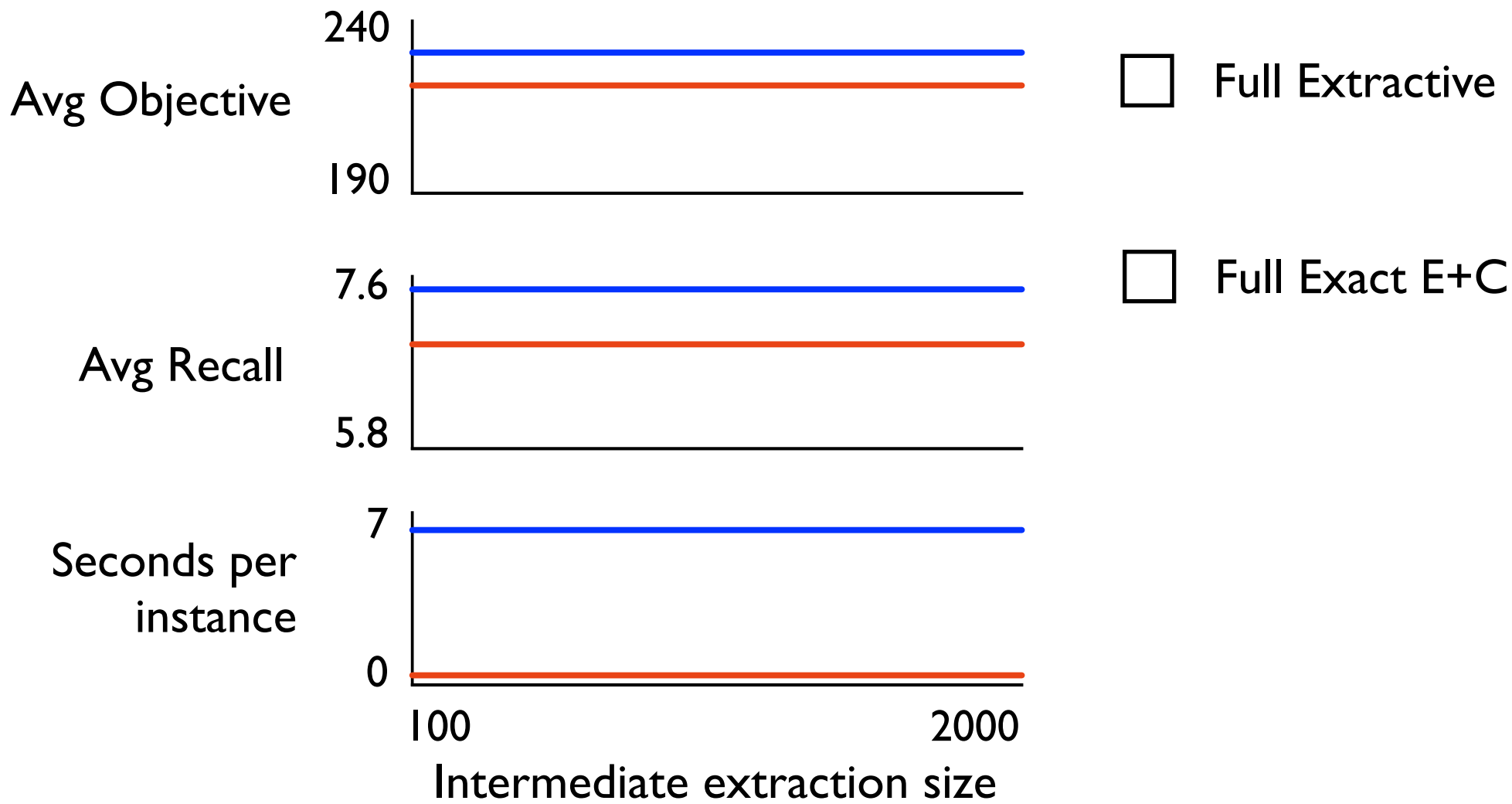

Coarse-to-fine Decoding

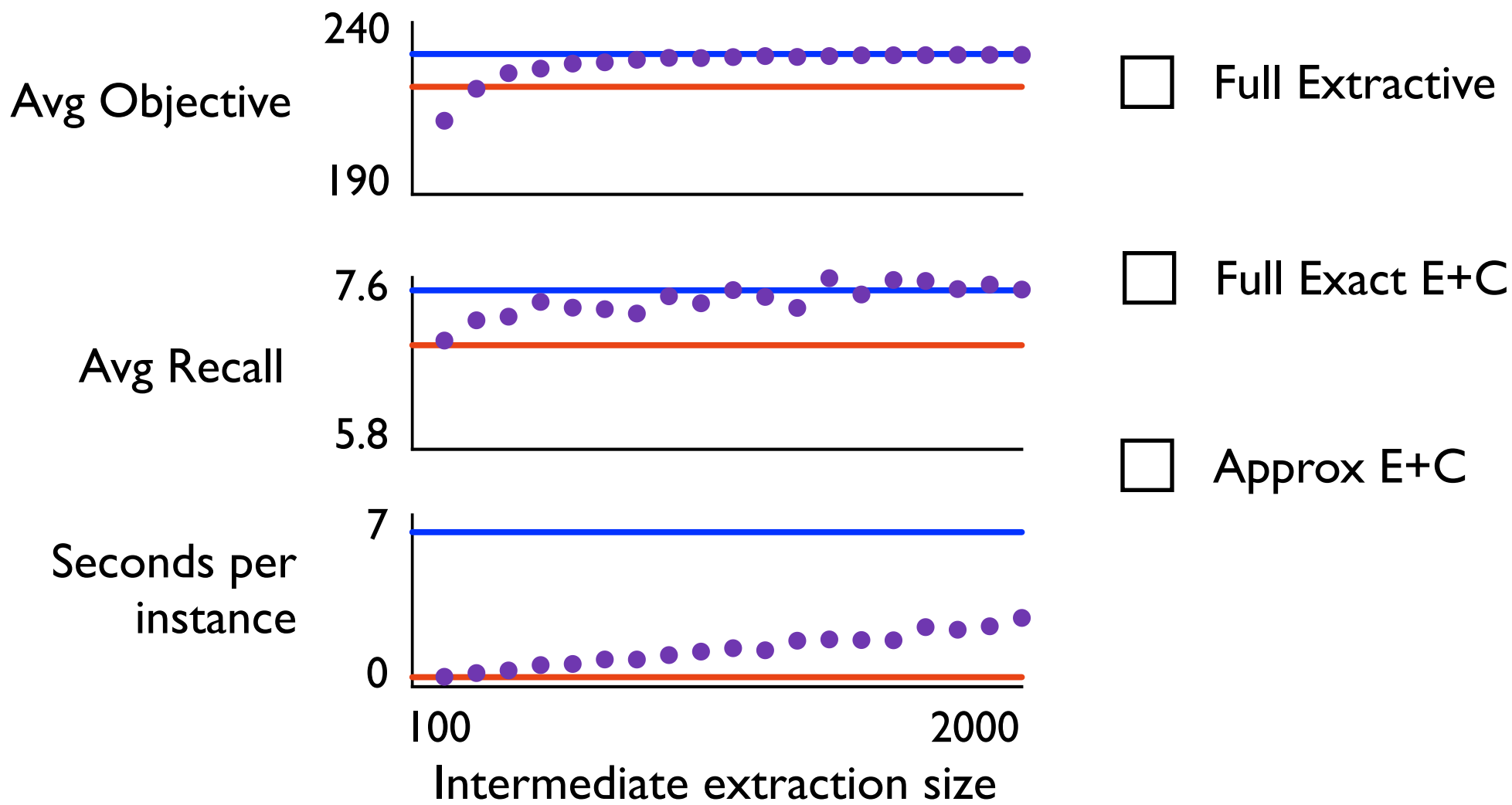

Coarse-to-fine Decoding

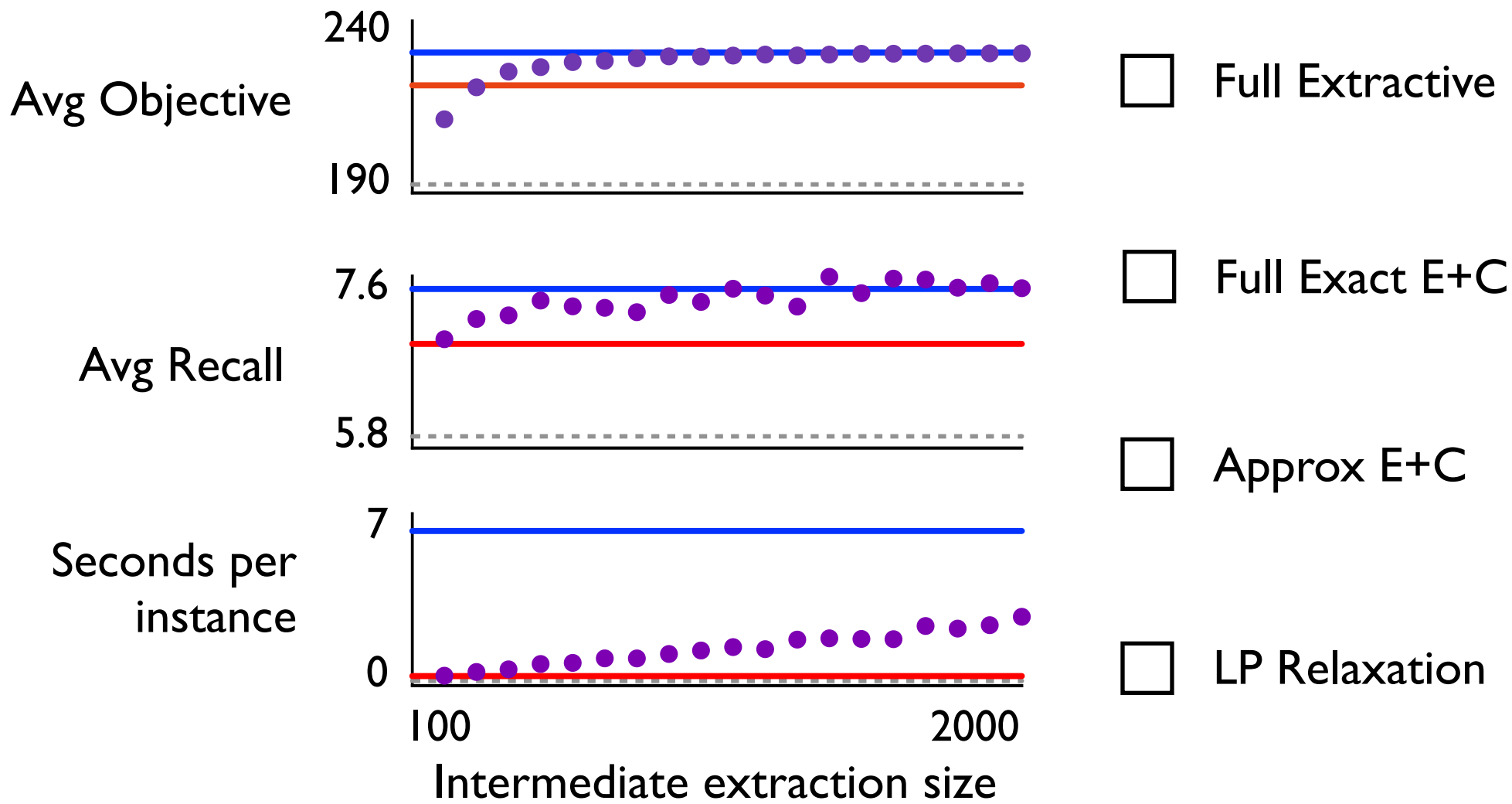

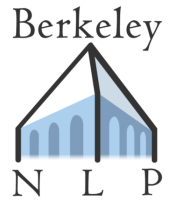

Piano Music Transcription

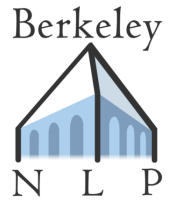

Piano Music Transcription

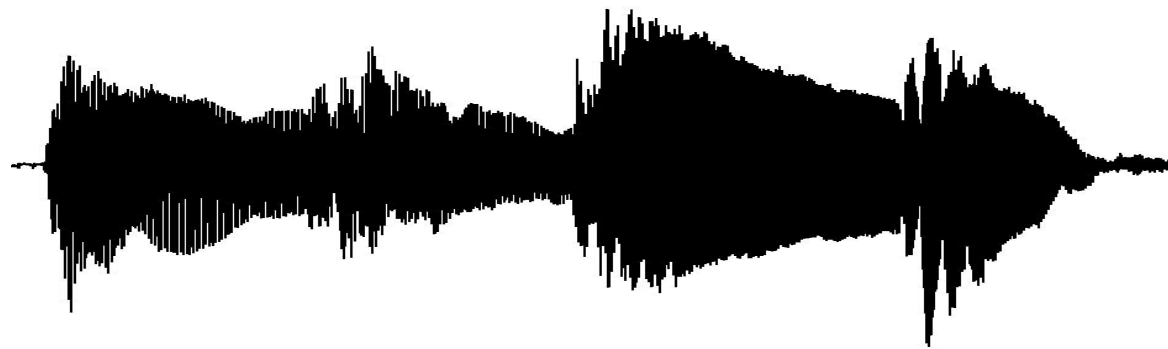

Piano Music Transcription

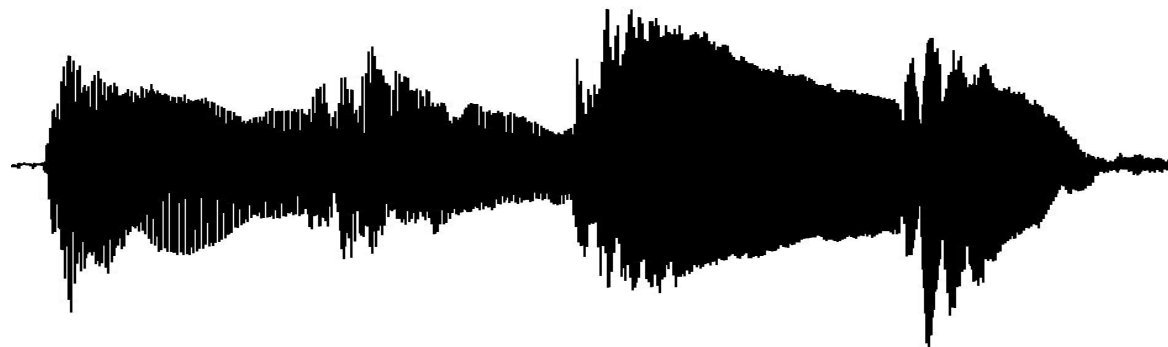

Piano Music Transcription

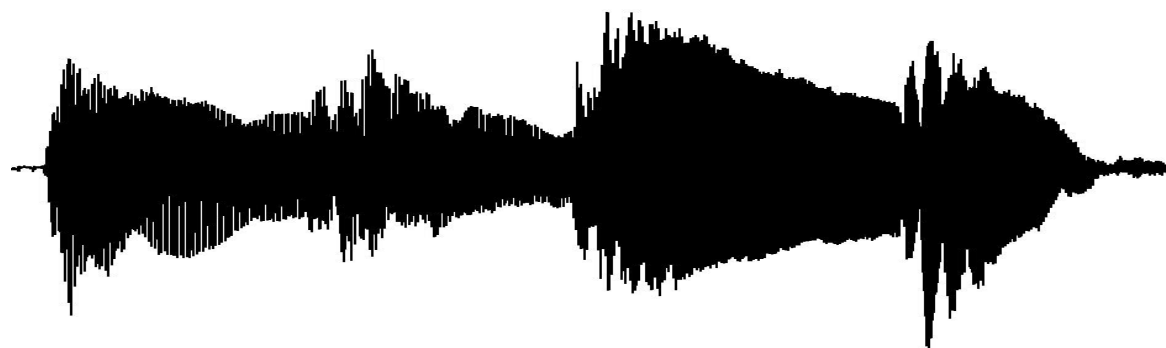
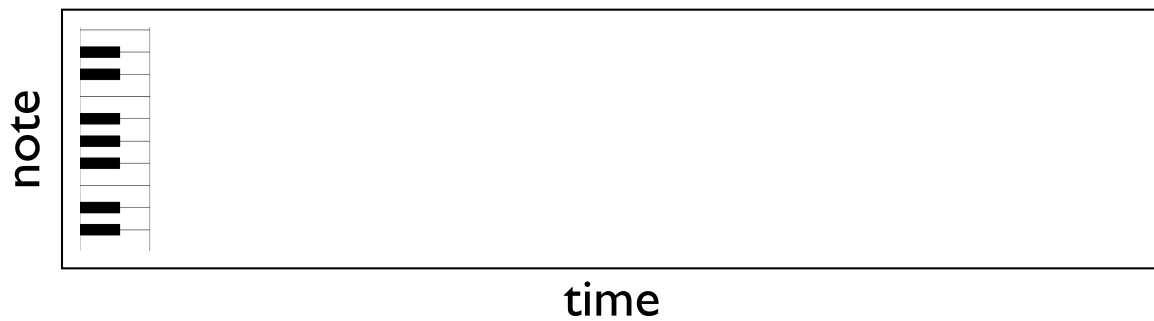

Piano Sounds

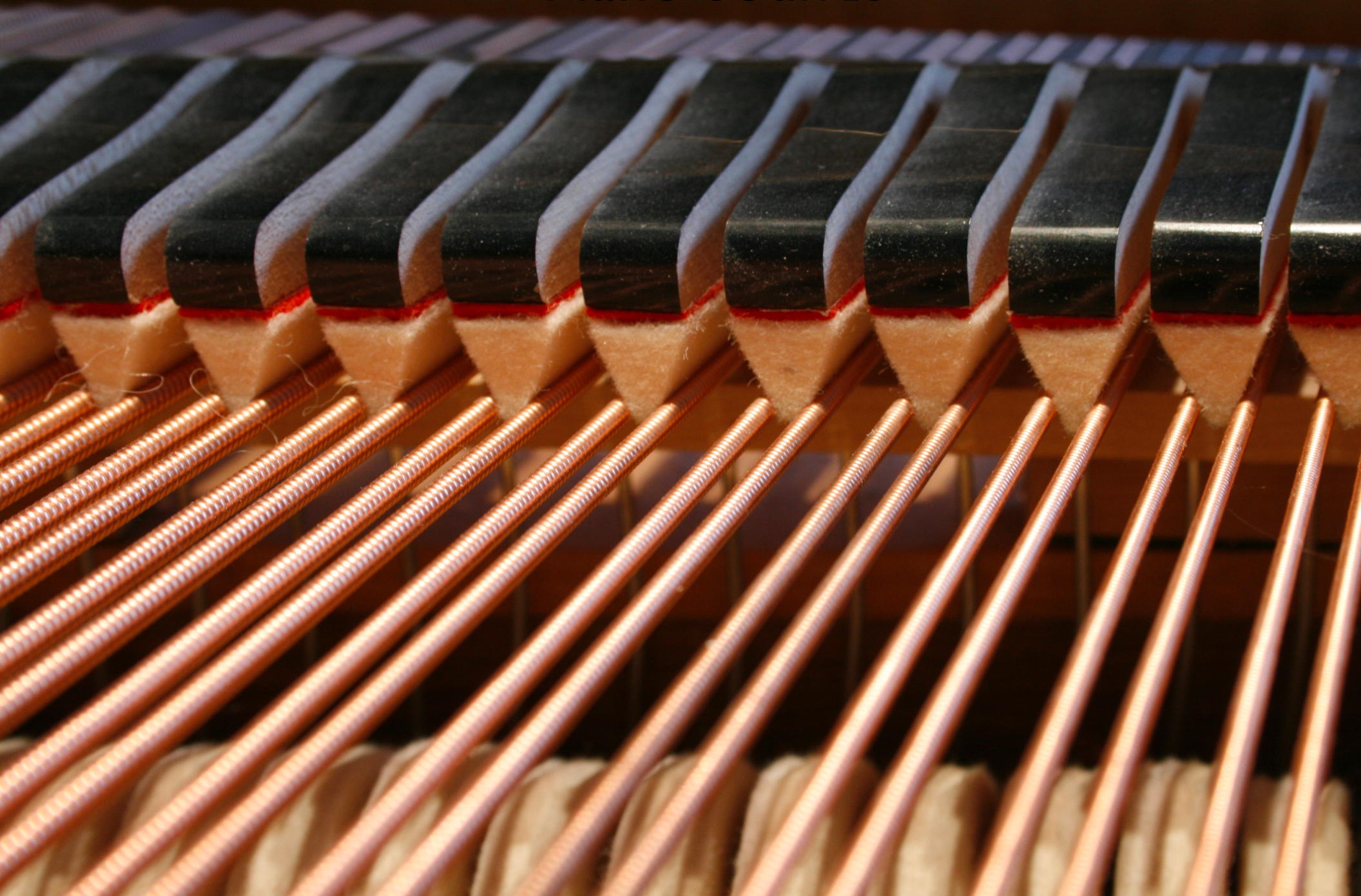

Piano Sounds

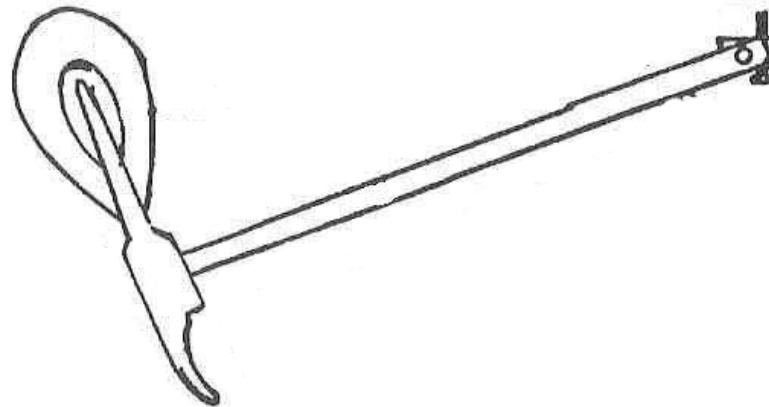
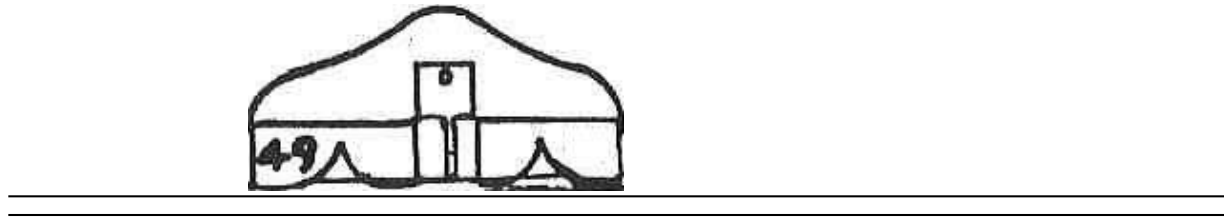

Piano Sounds

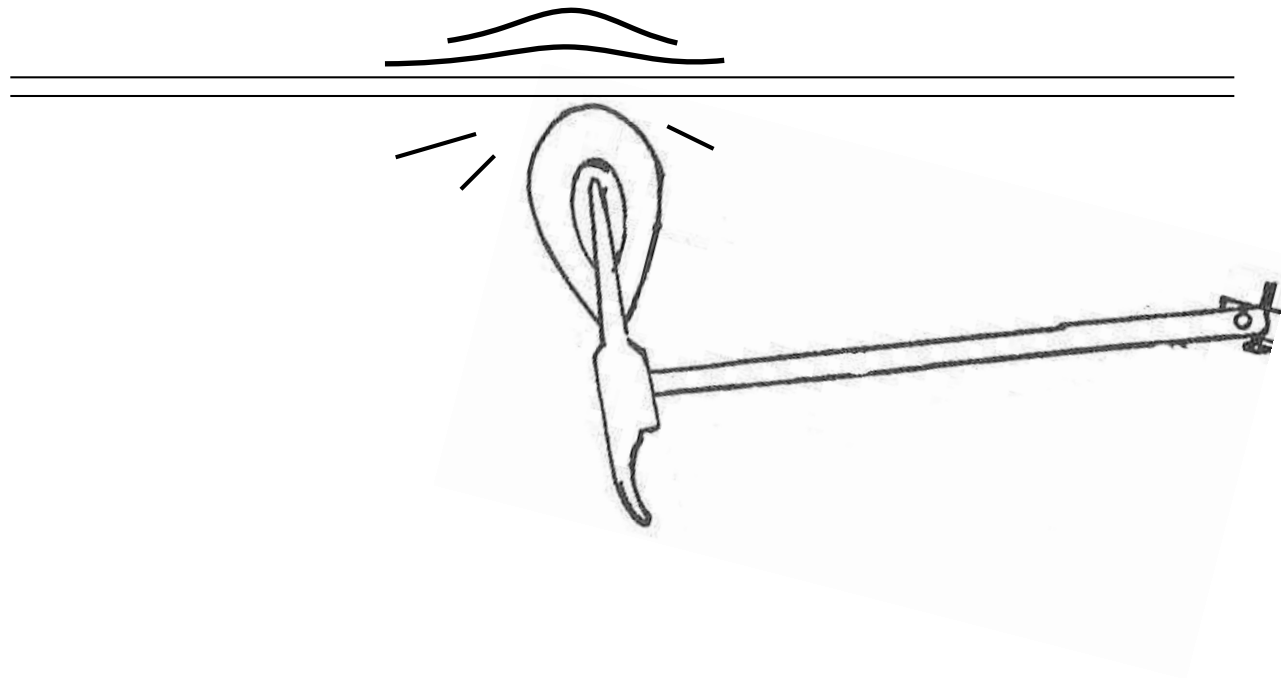

Piano Sounds

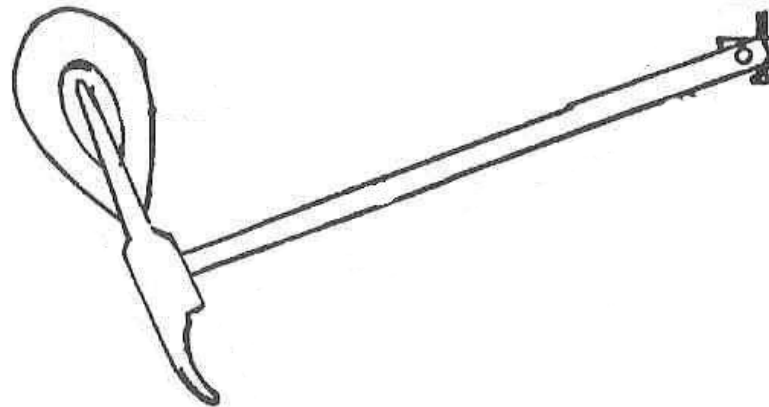
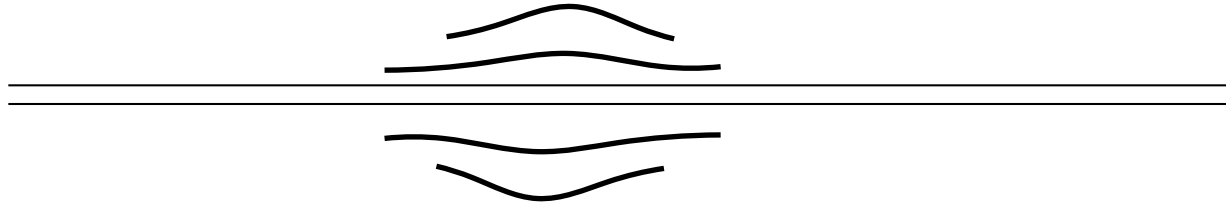

Piano Sounds

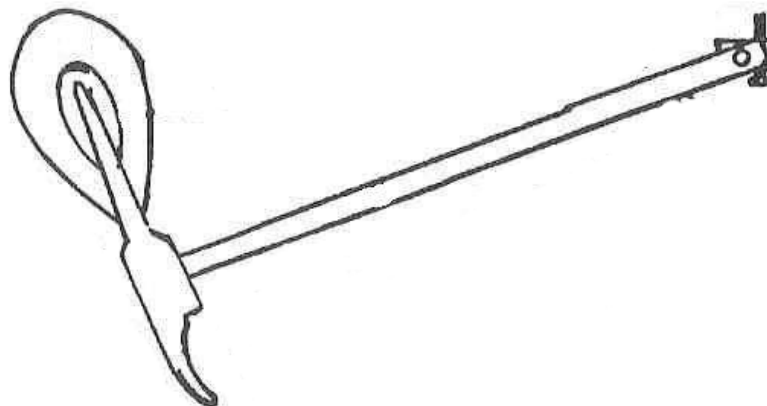
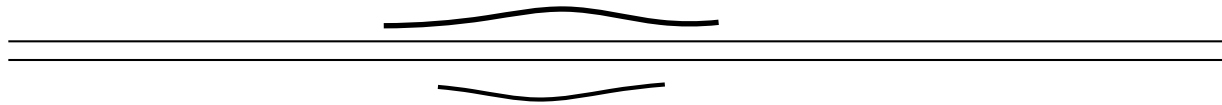

Piano Sounds

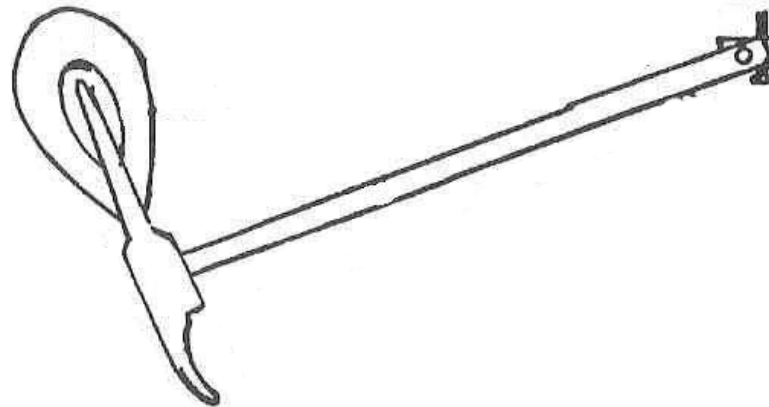
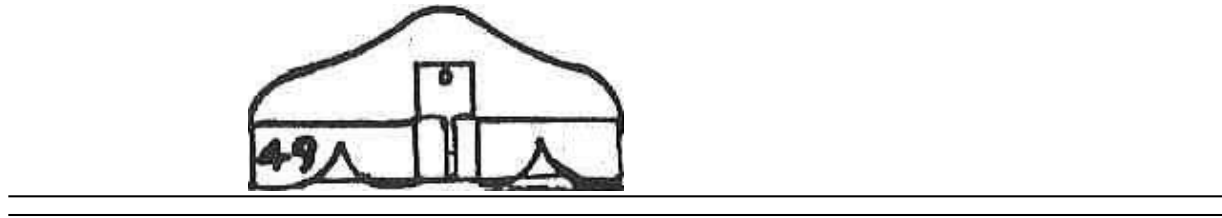

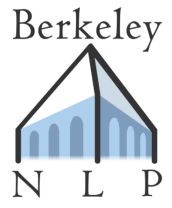

Piano Sounds

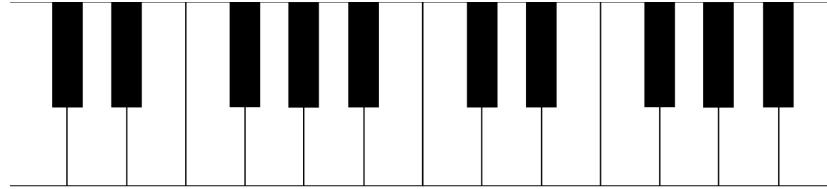

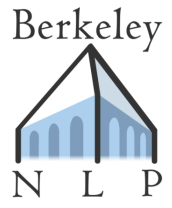

Piano Sounds

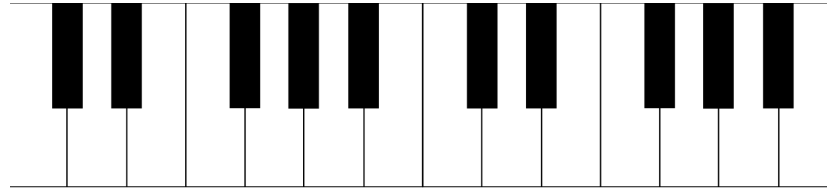

Piano Sounds

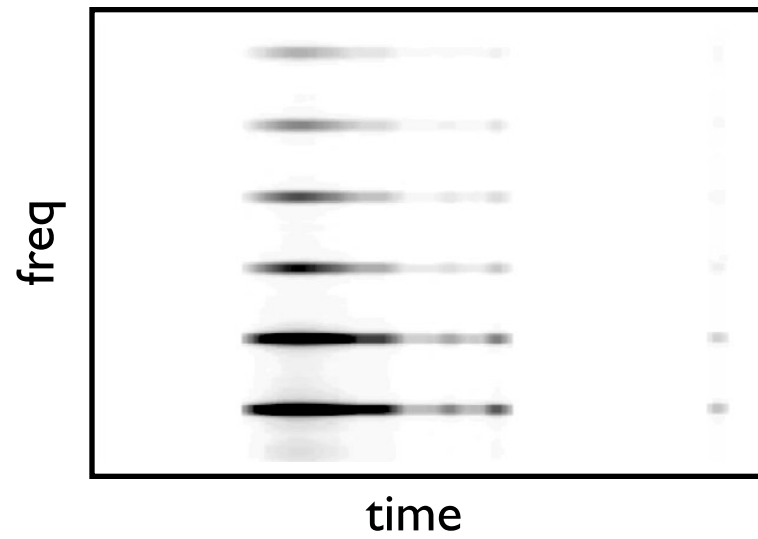
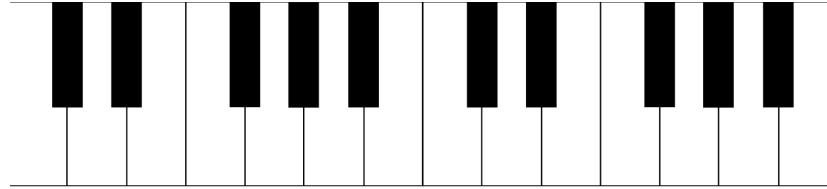

Piano Sounds

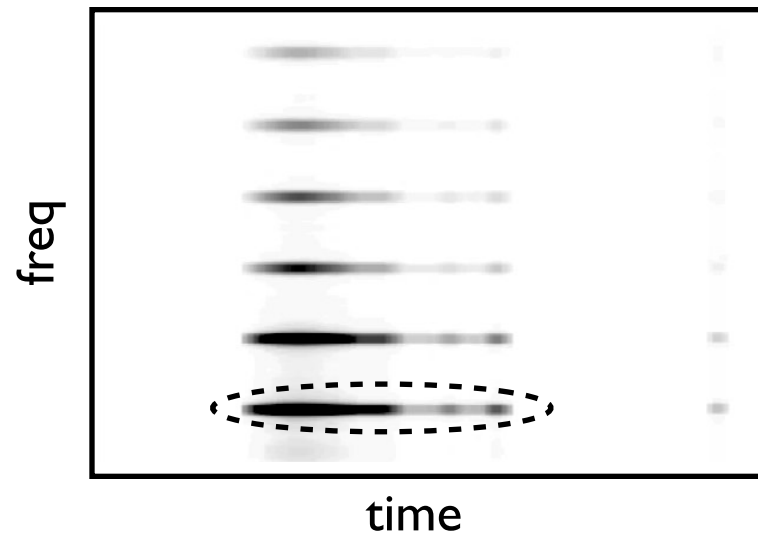
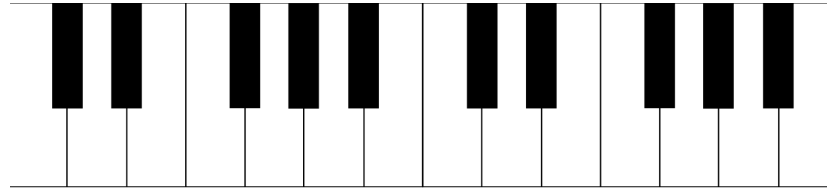

Piano Sounds

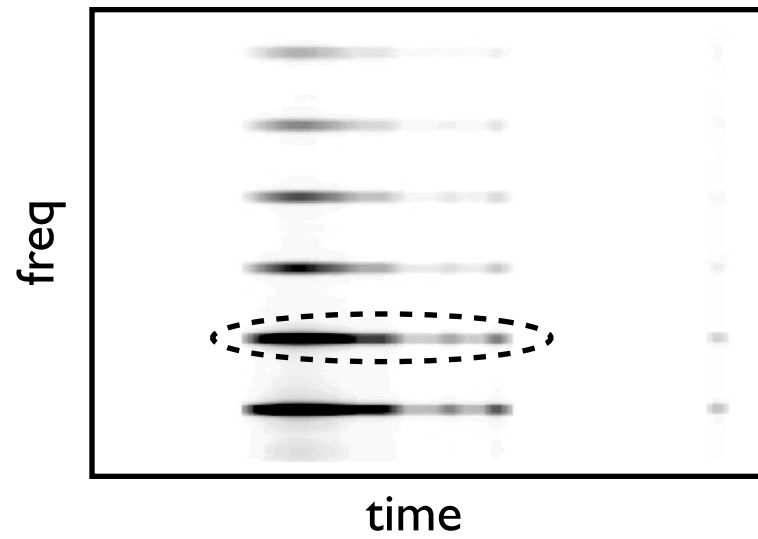
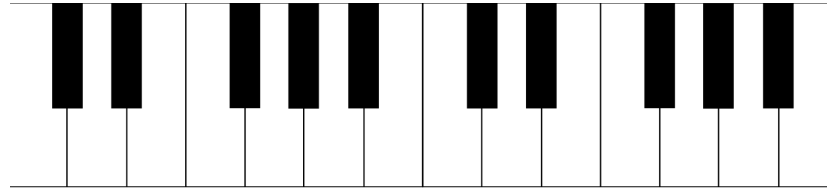

Piano Sounds

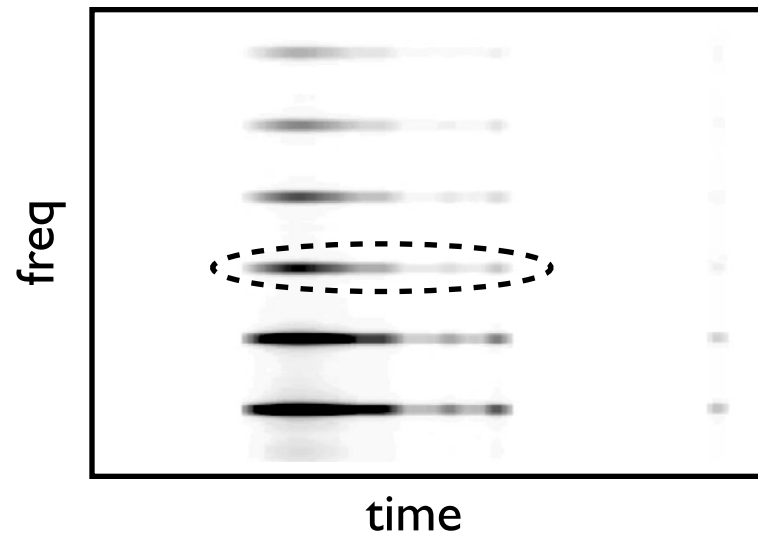
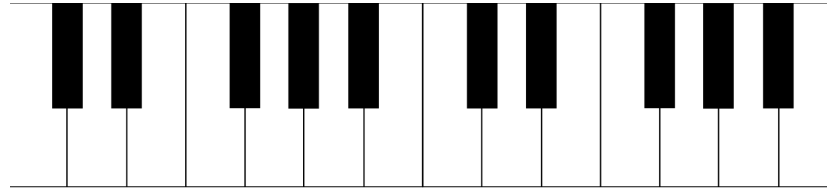

Spectral Shape

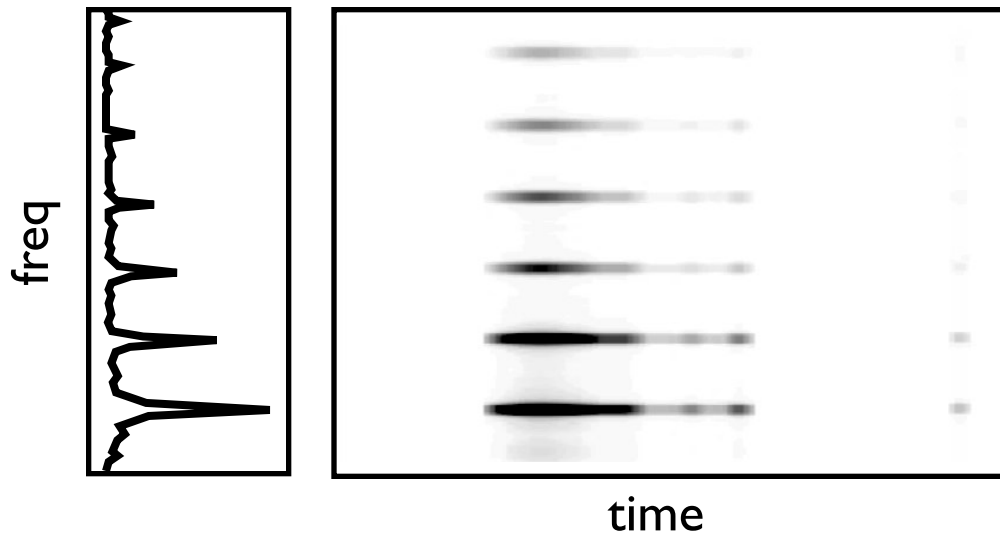
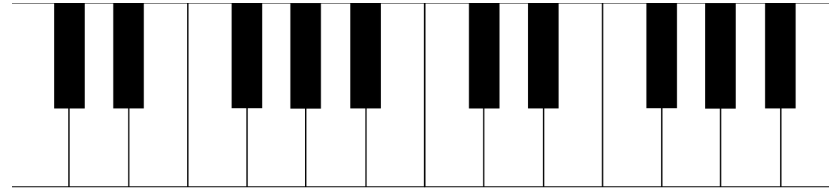

Spectral Shape

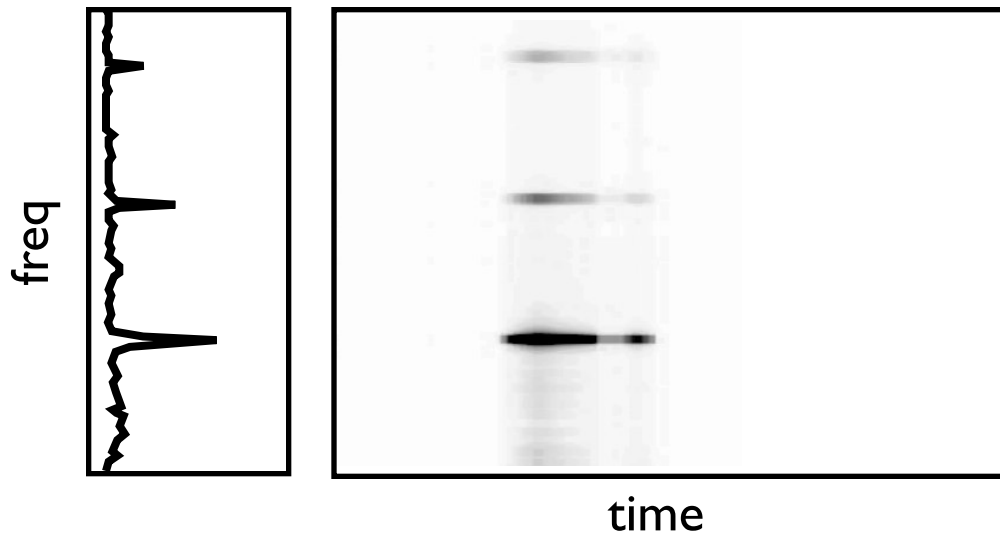
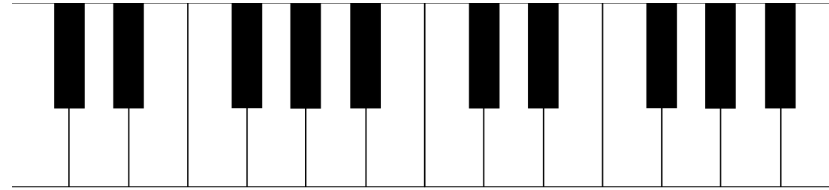

Spectral Shape

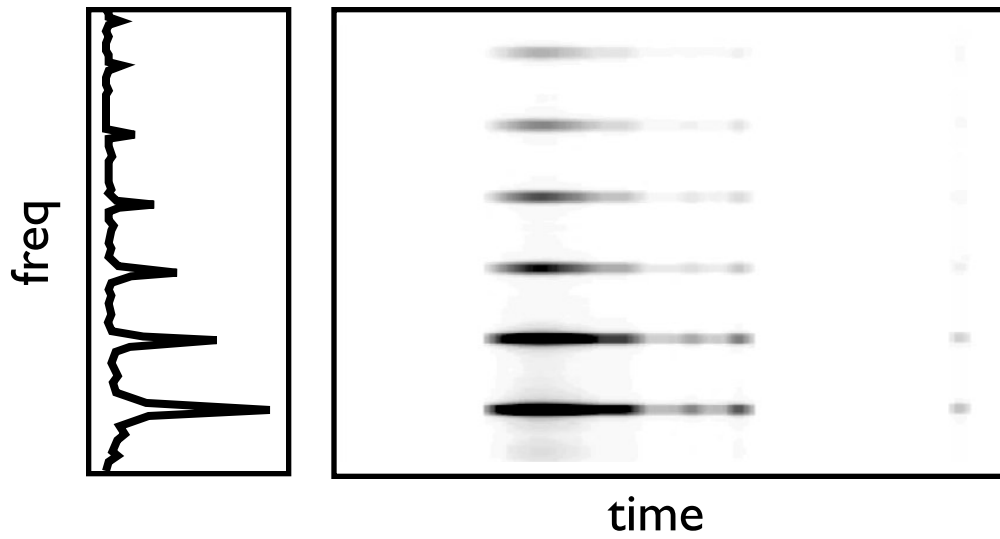
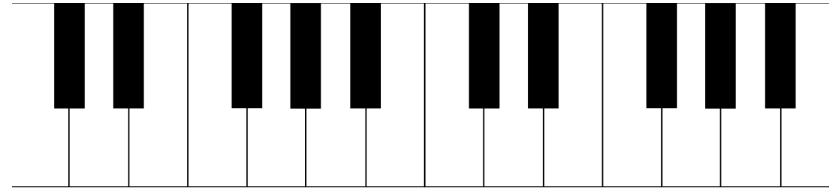

Spectral Shape

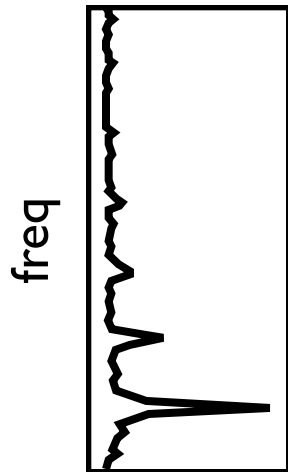
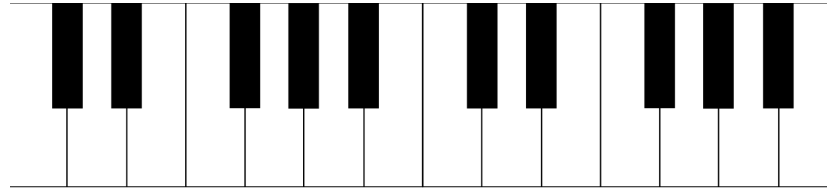
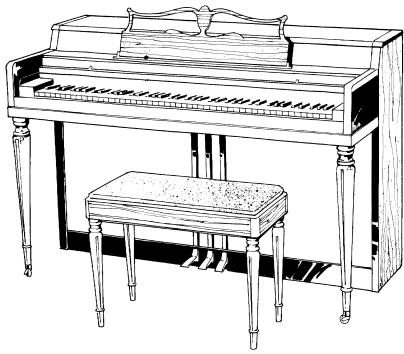

Temporal Shape

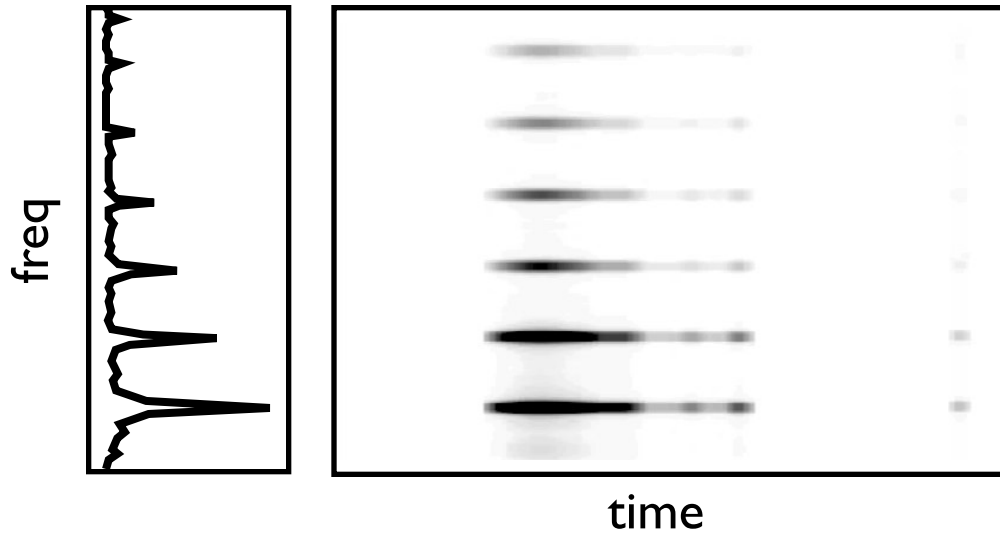
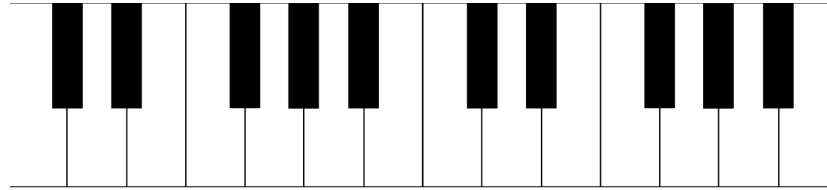

Temporal Shape

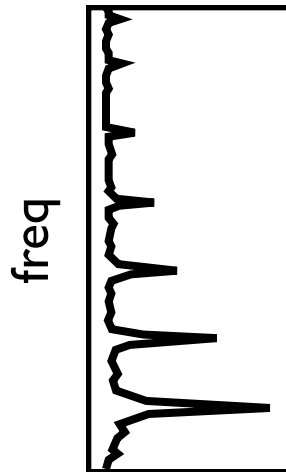
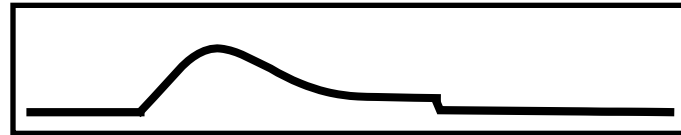
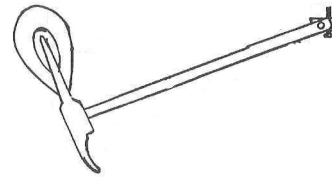
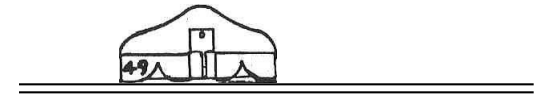
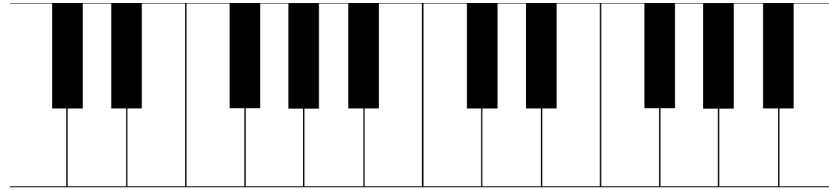

time

Temporal Shape

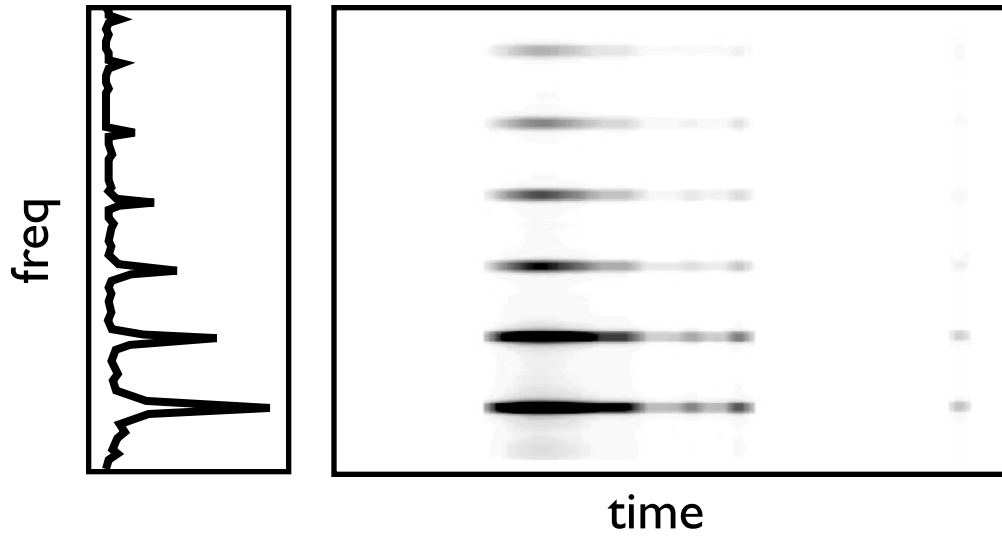
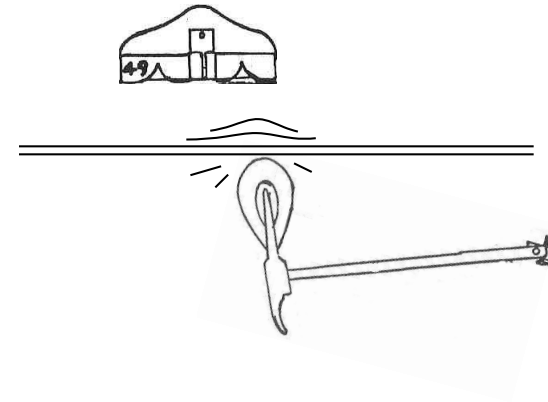
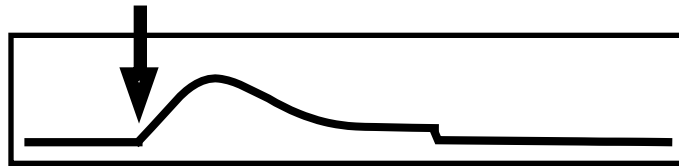
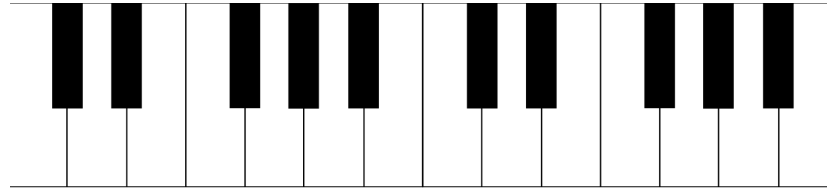

Temporal Shape

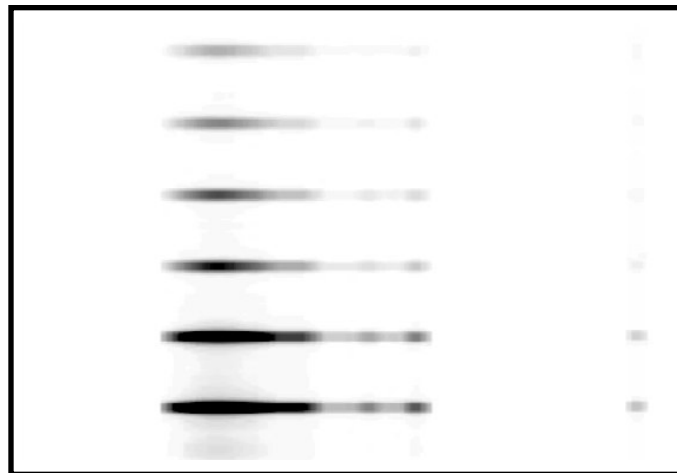
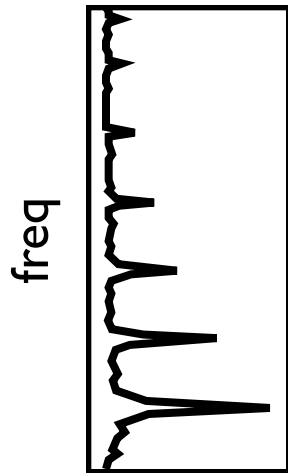
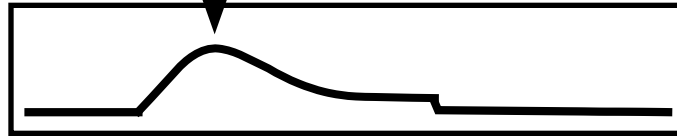
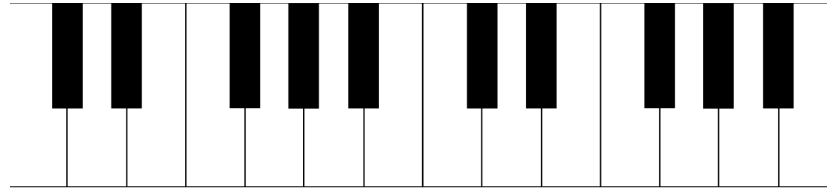

time

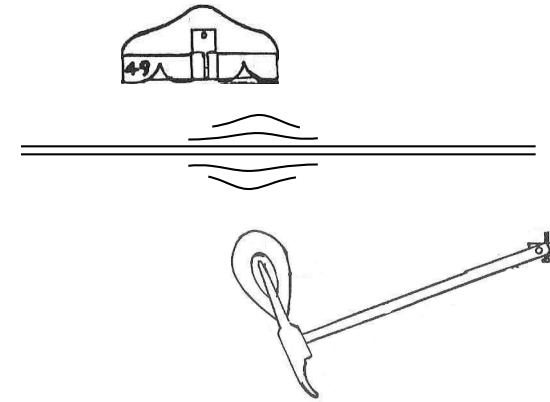

Temporal Shape

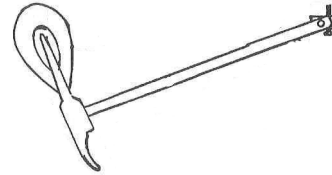
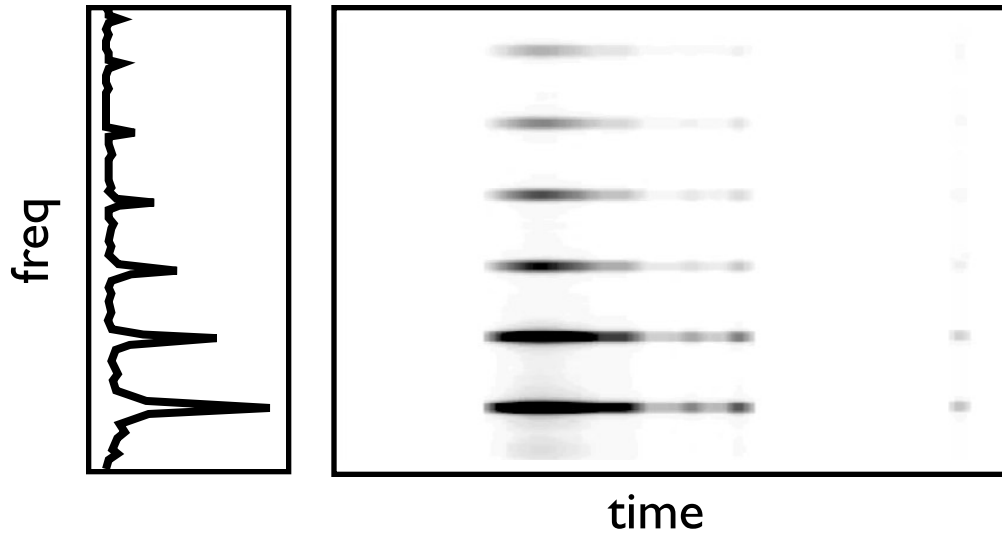
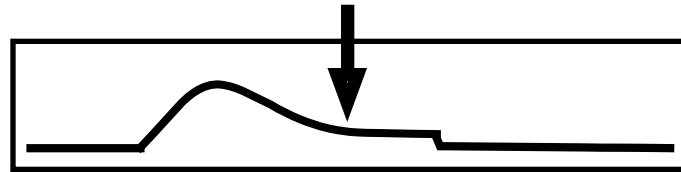
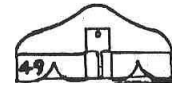
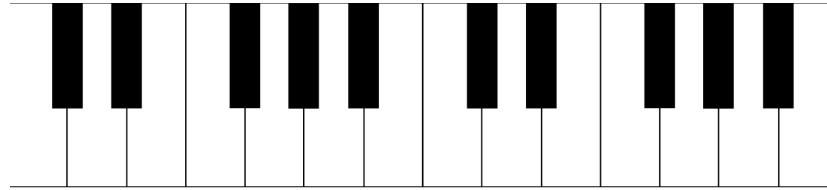

Temporal Shape

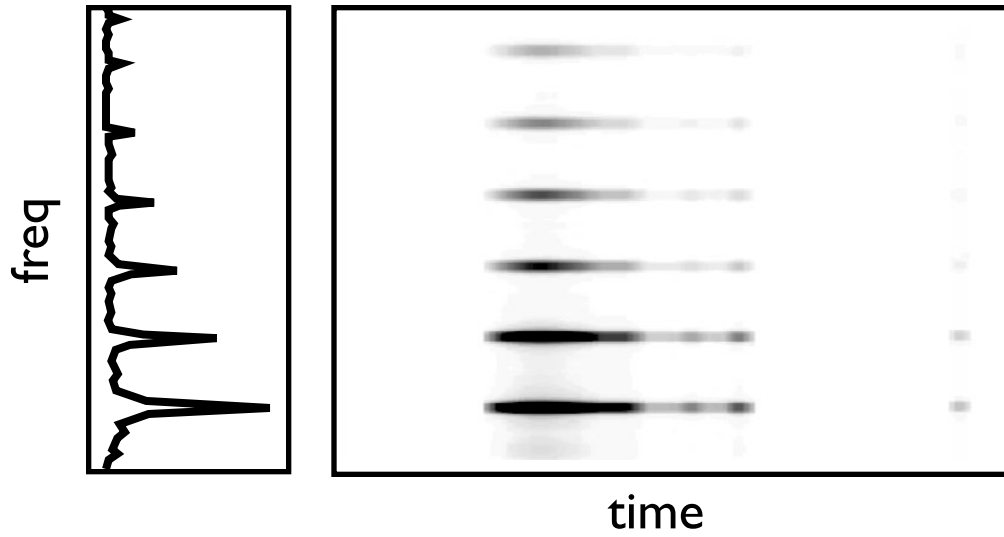
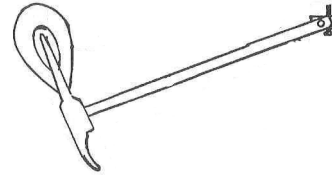
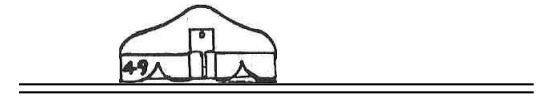
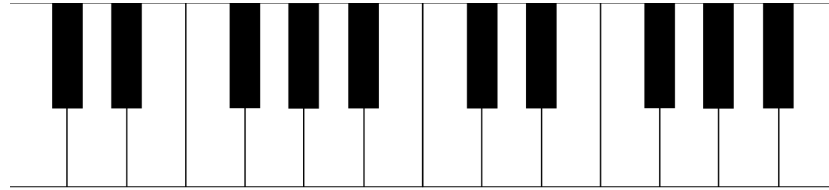

Temporal Shape

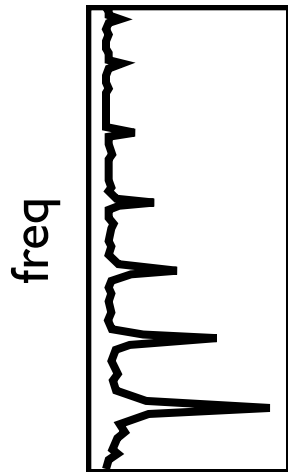
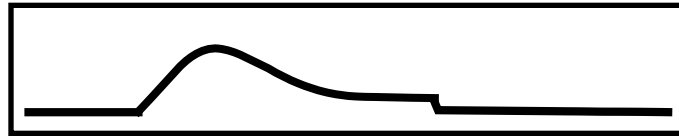
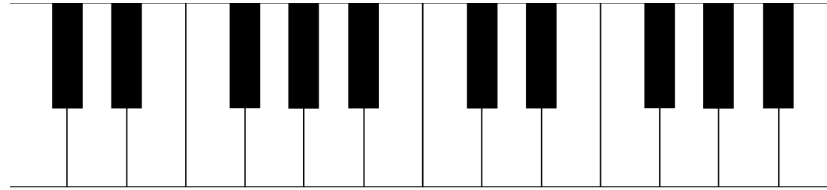

time

Temporal Shape

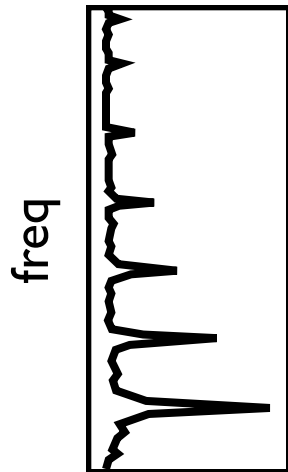
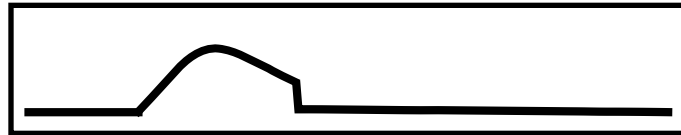
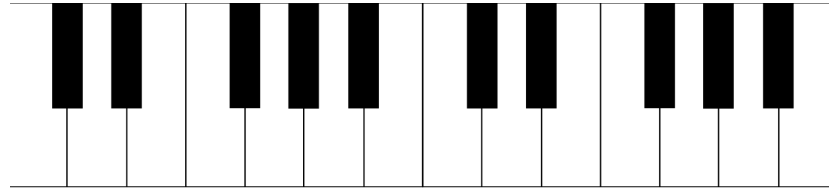

time

Temporal Shape

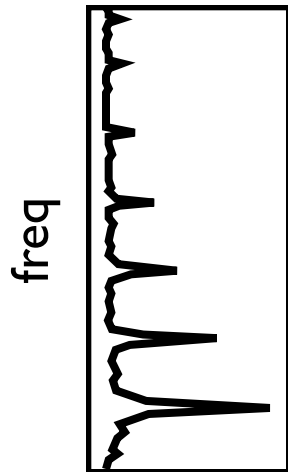
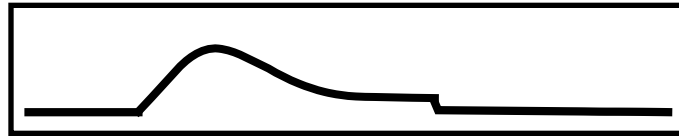
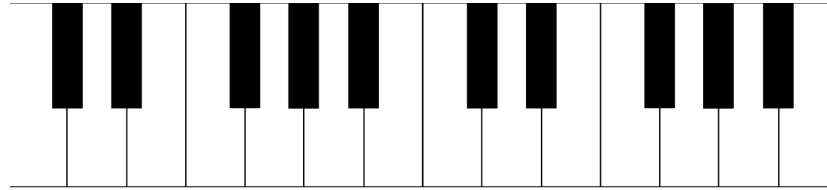

time

Temporal Shape

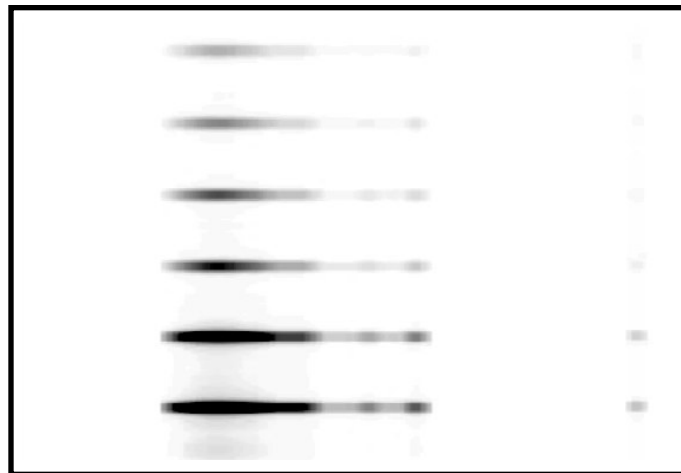
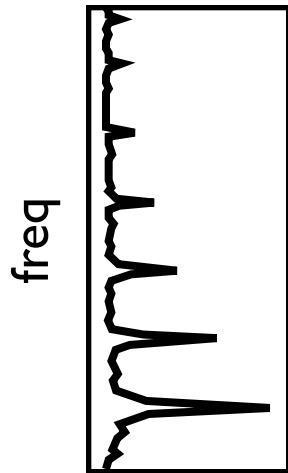
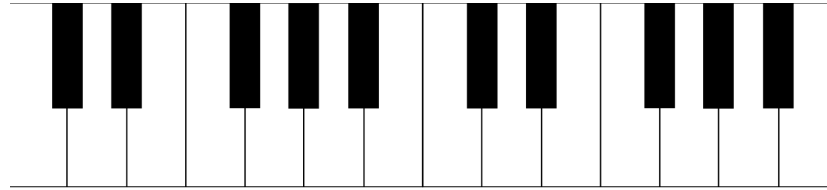

time

Temporal Shape

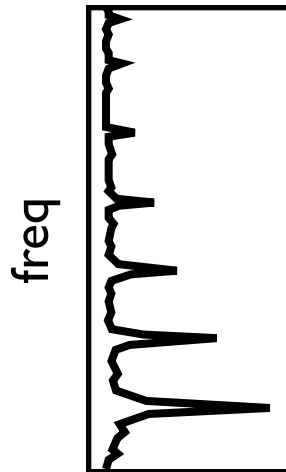
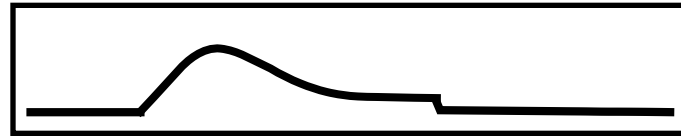
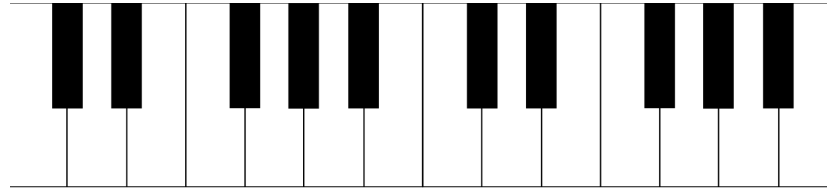

time

Temporal Shape

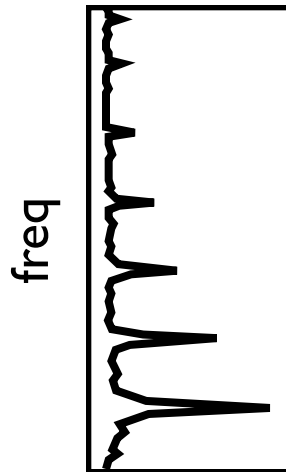
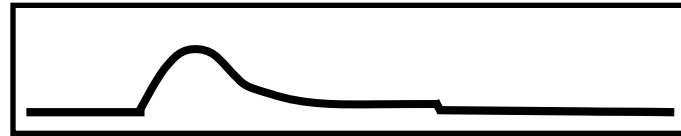
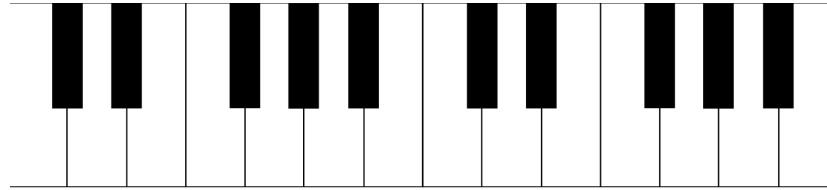
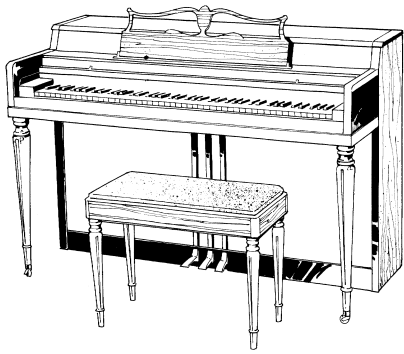

time

Berkeley



Temporal Shape

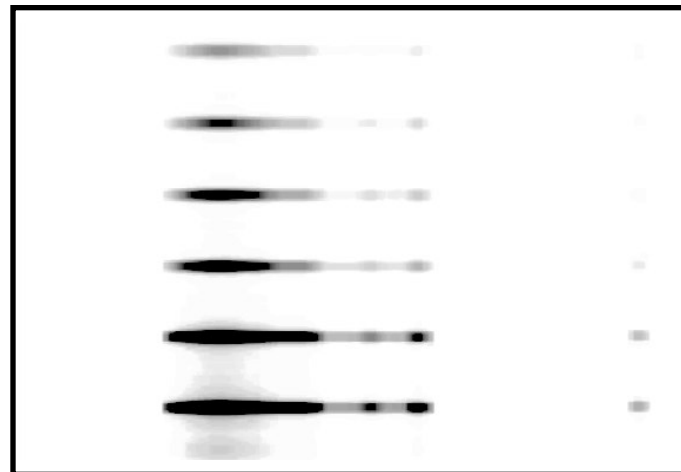
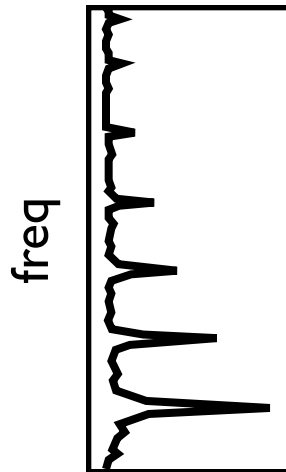
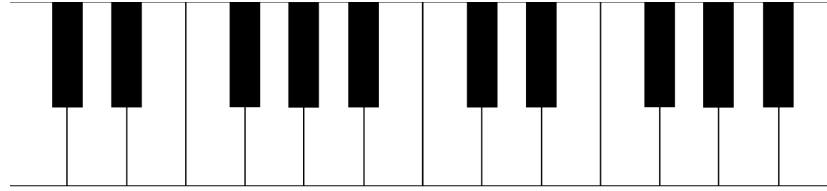

time

Polyphony

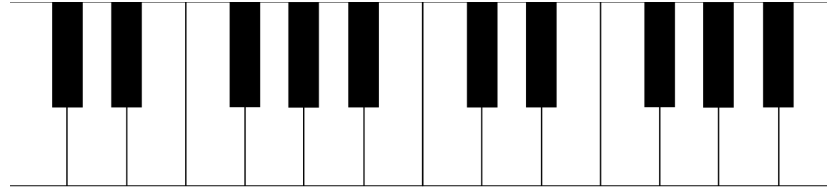

Polyphony

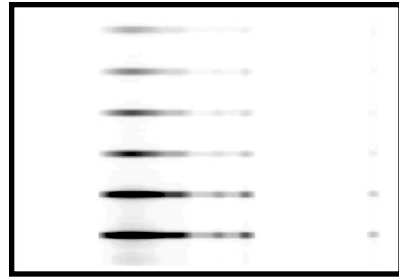
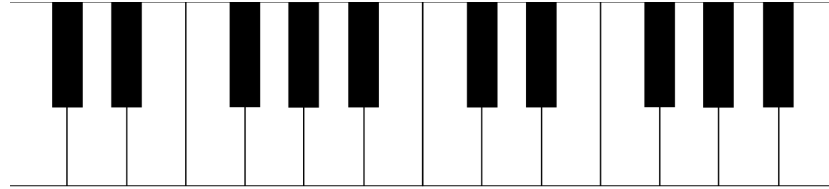

Polyphony

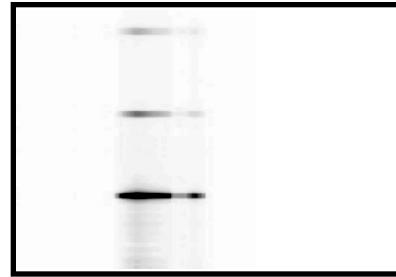
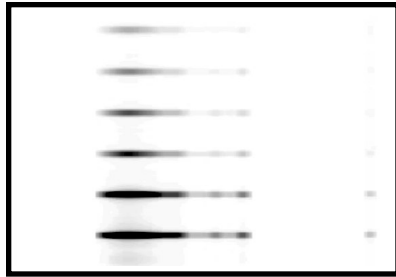
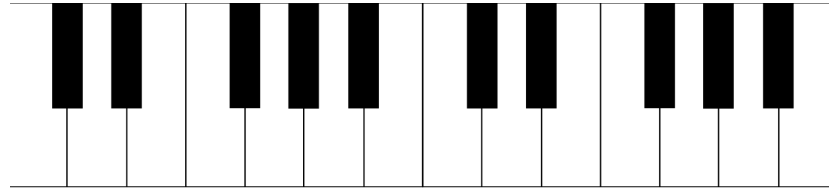

Polyphony

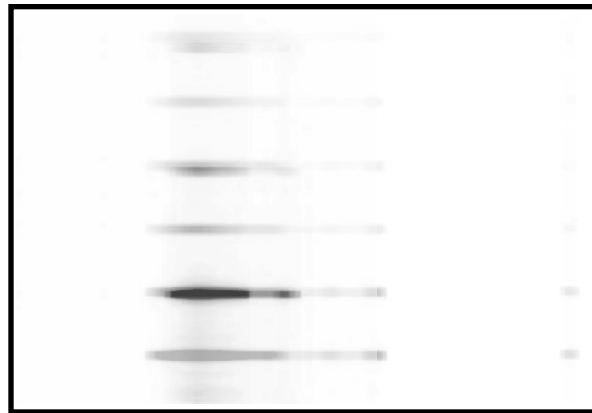
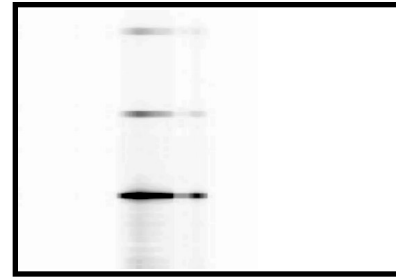
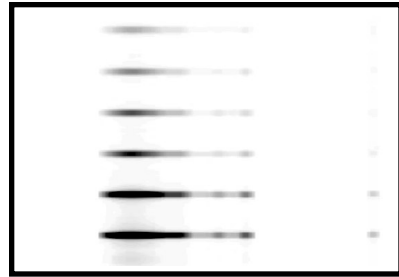
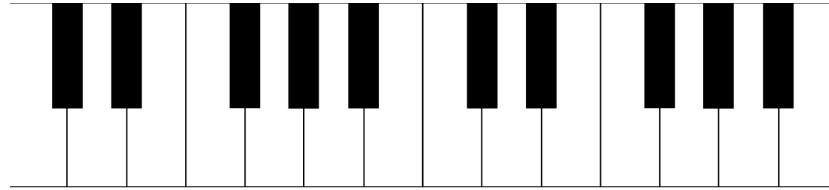

Polyphony

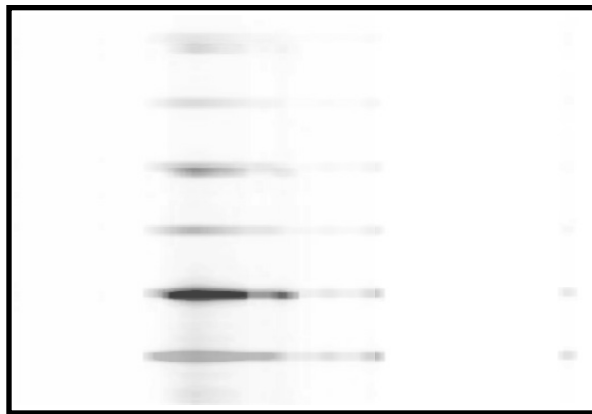
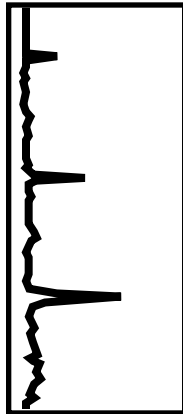
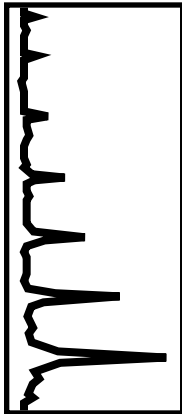
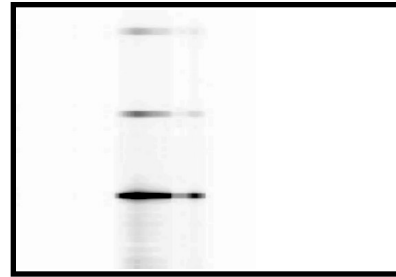
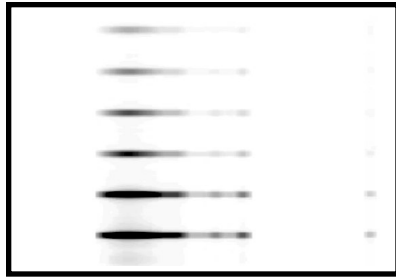
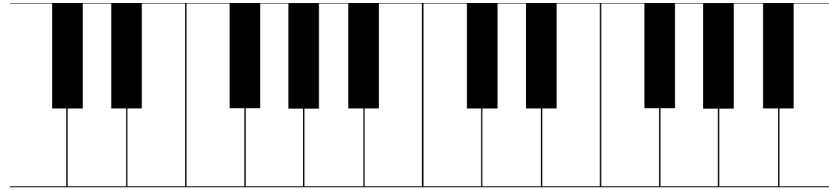

Polyphony

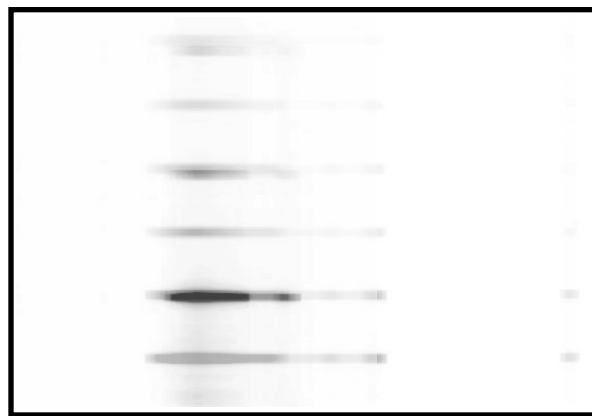
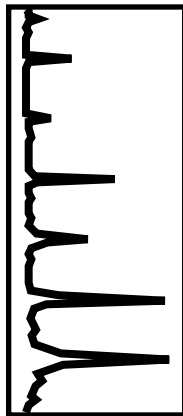
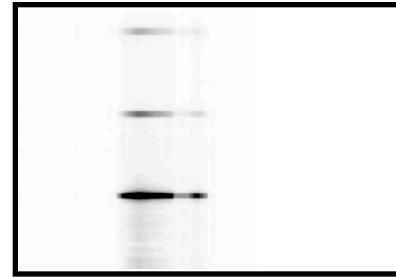
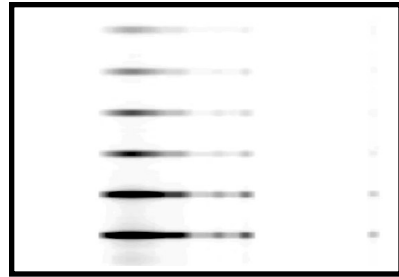
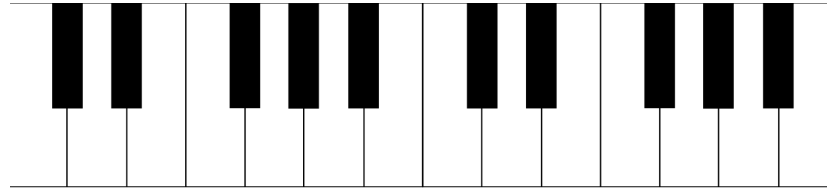

Polyphony

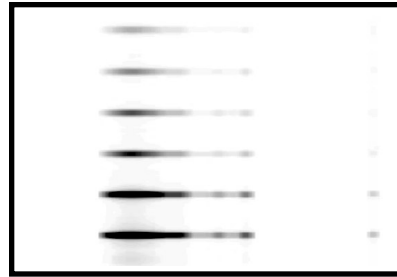
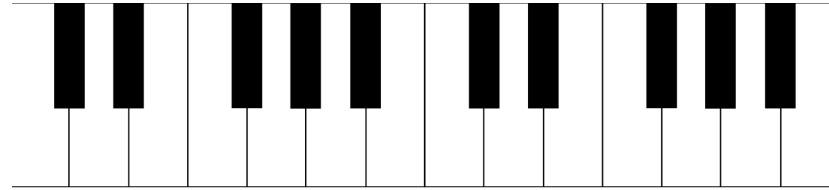

...

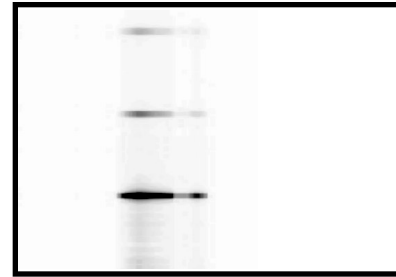

Polyphony

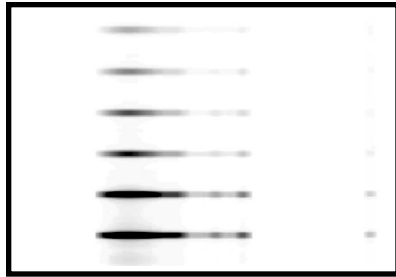
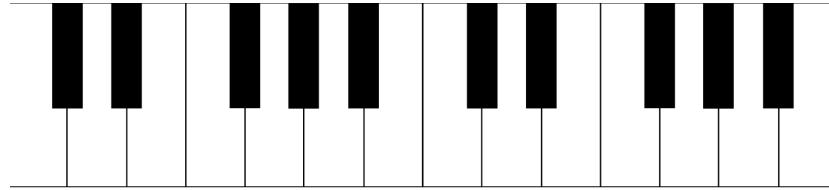

...

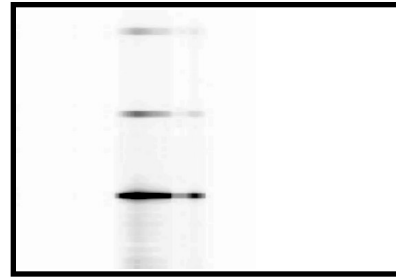

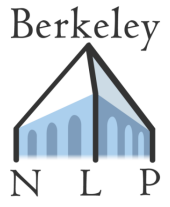

Generative Model

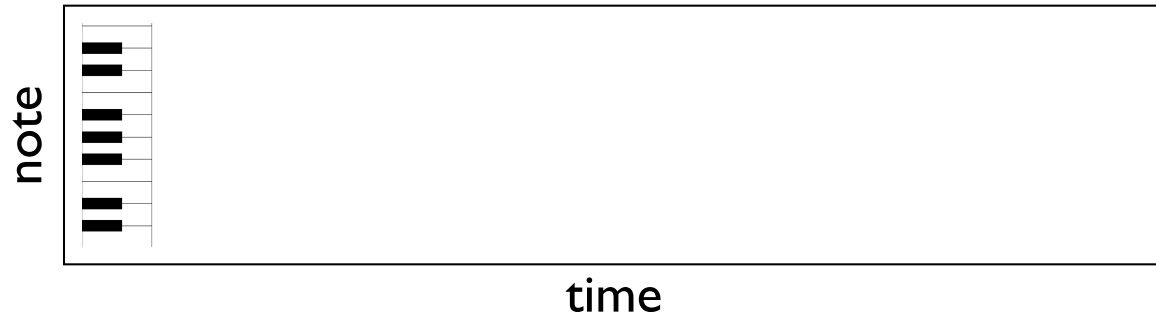

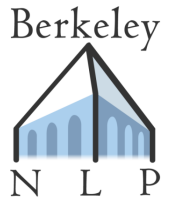

Generative Model

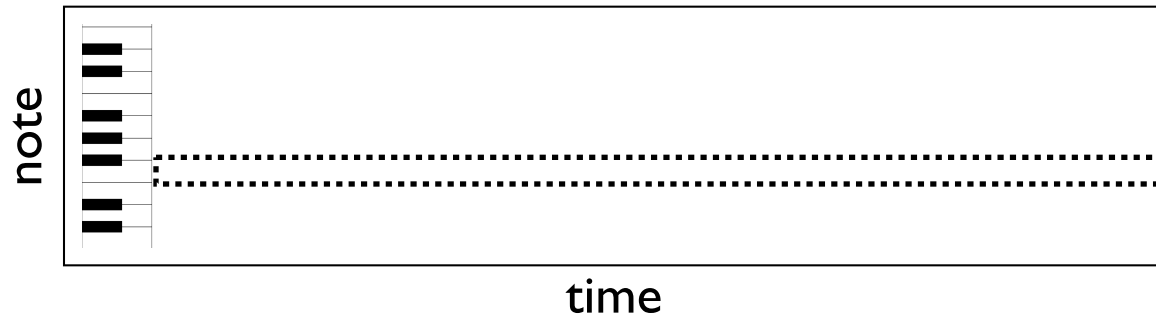

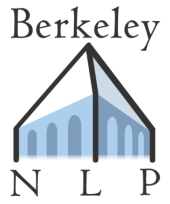

Generative Model

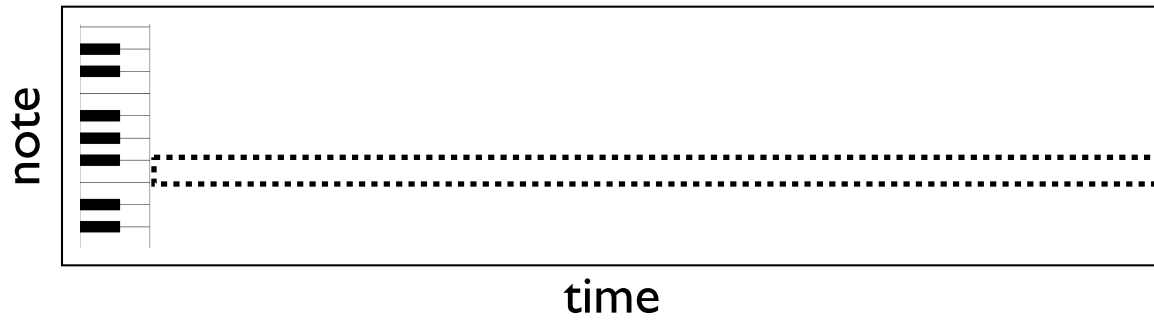

Note events

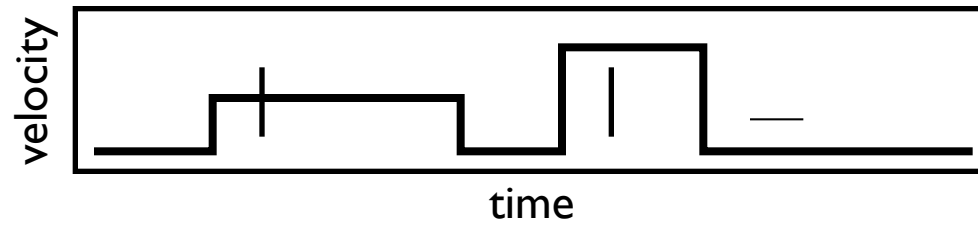

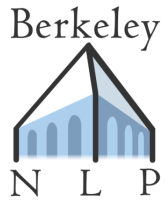

Generative Model

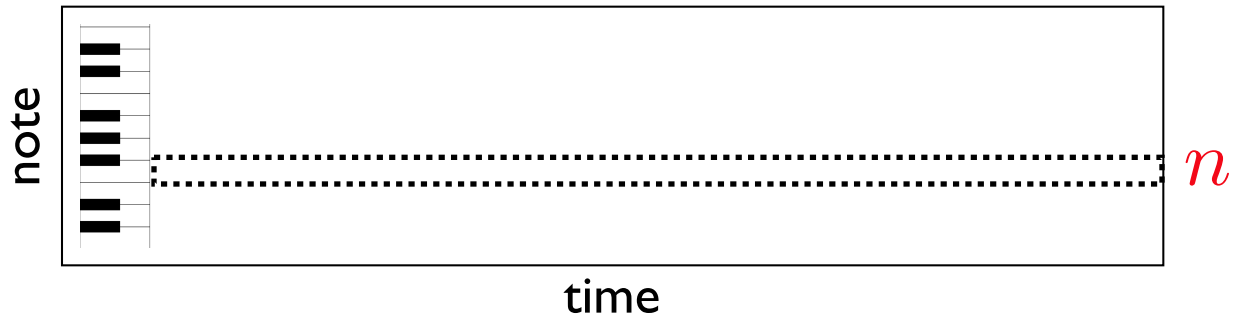

Note events

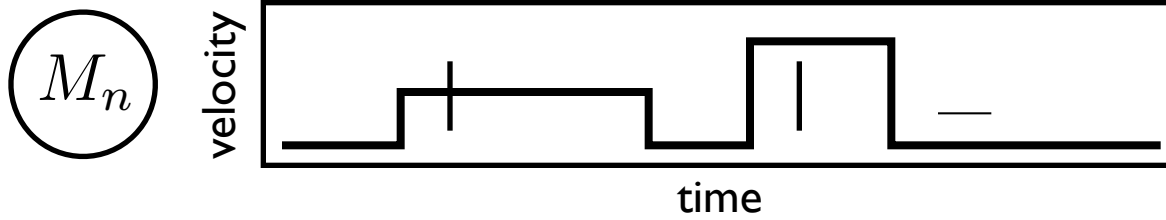

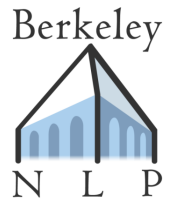

Generative Model

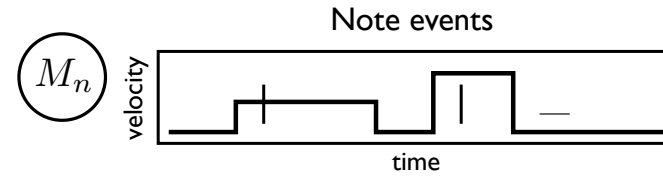

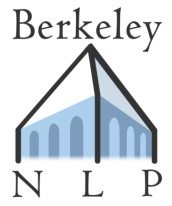

Generative Model

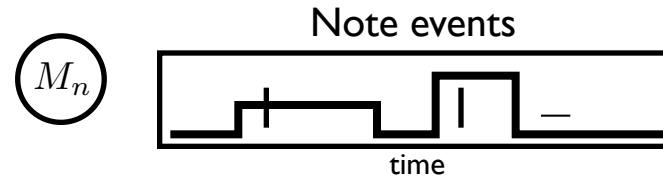

Generative Model

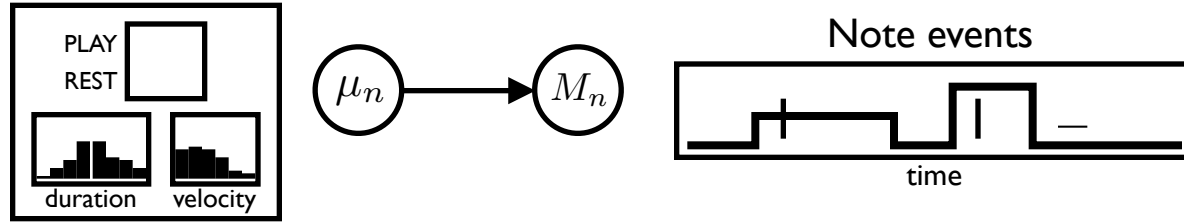

Generative Model

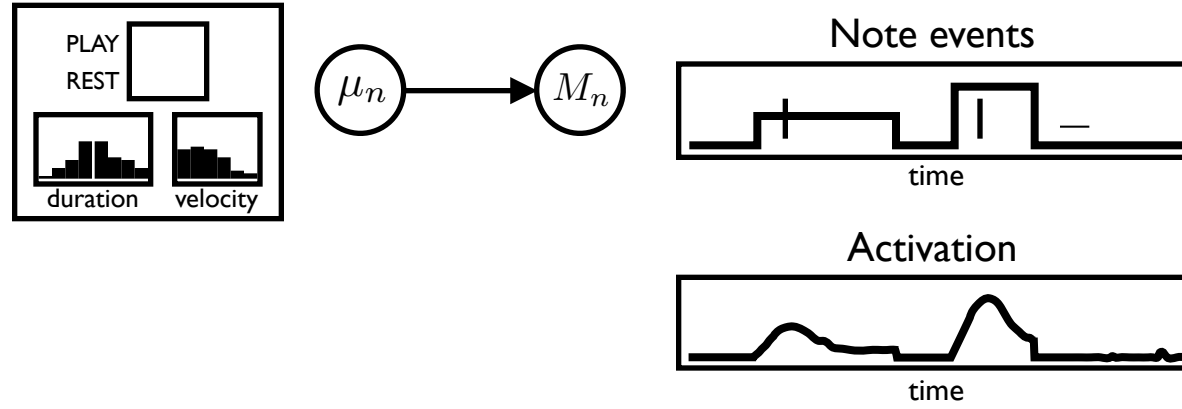

Generative Model

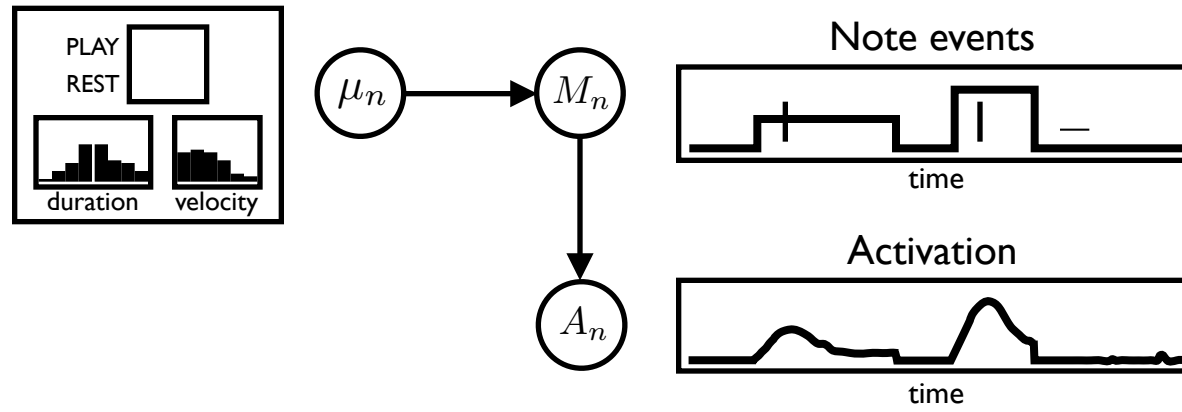

Generative Model

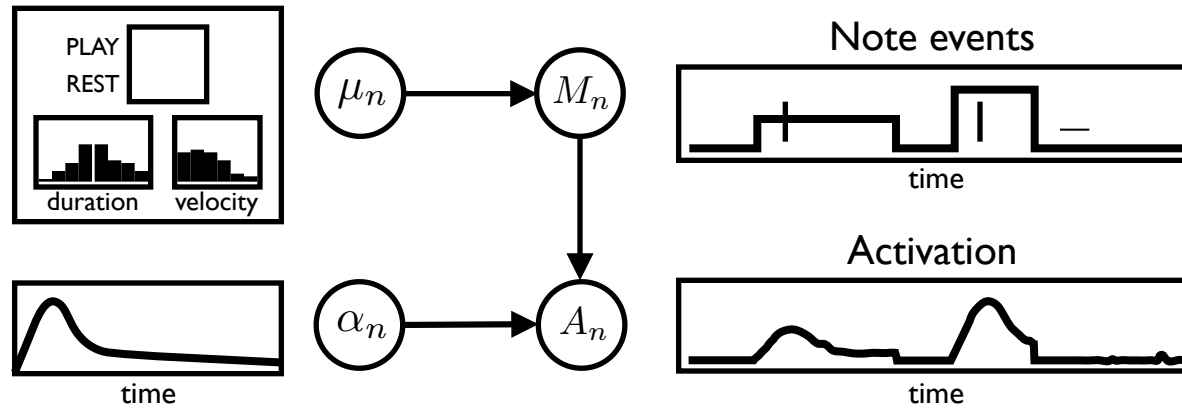

Generative Model

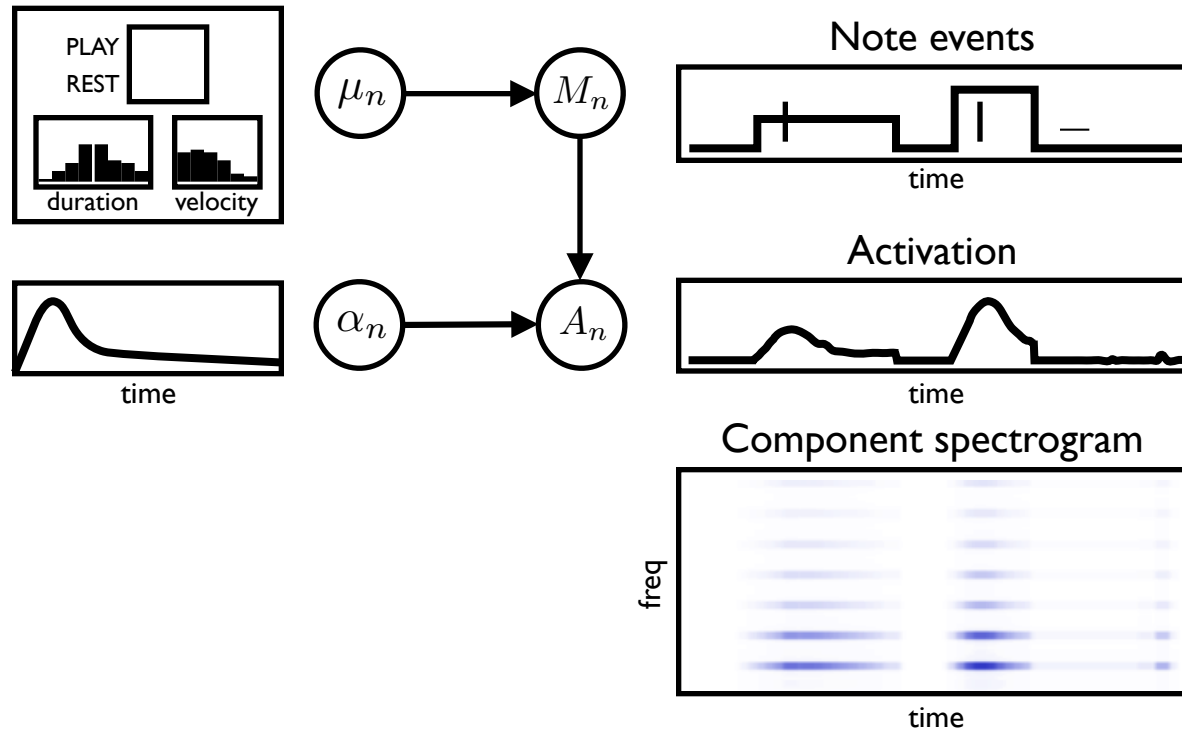

Generative Model

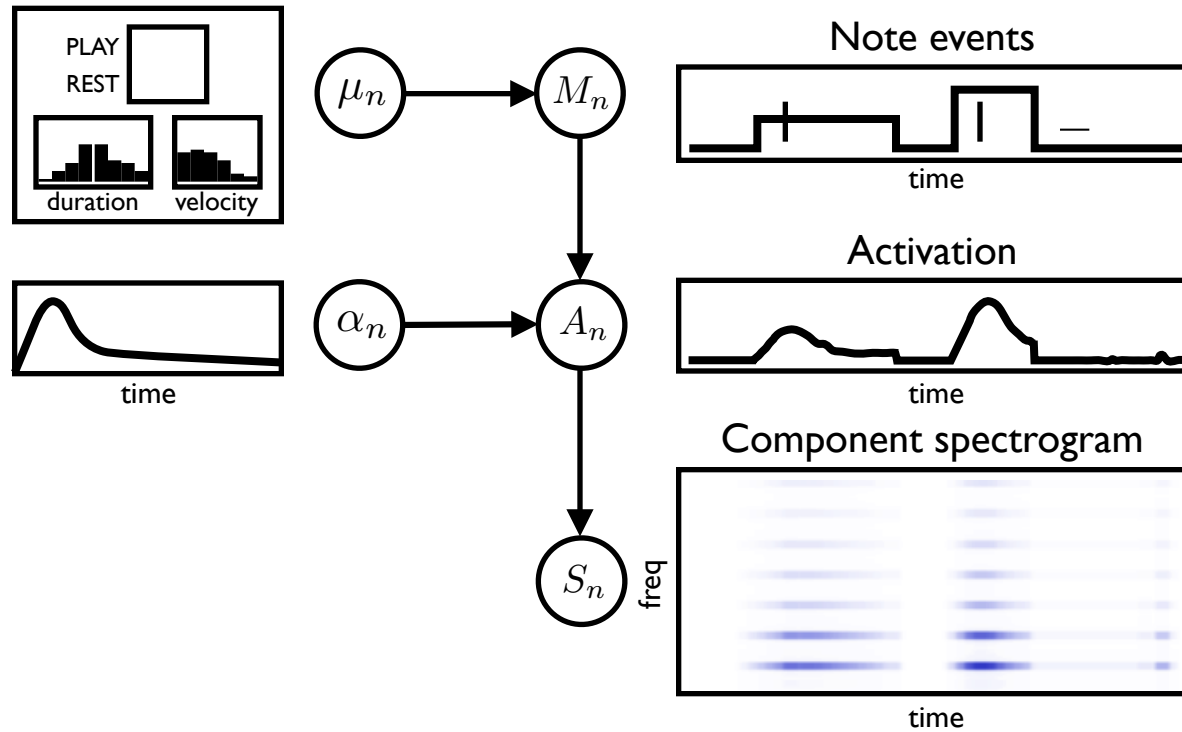

Generative Model

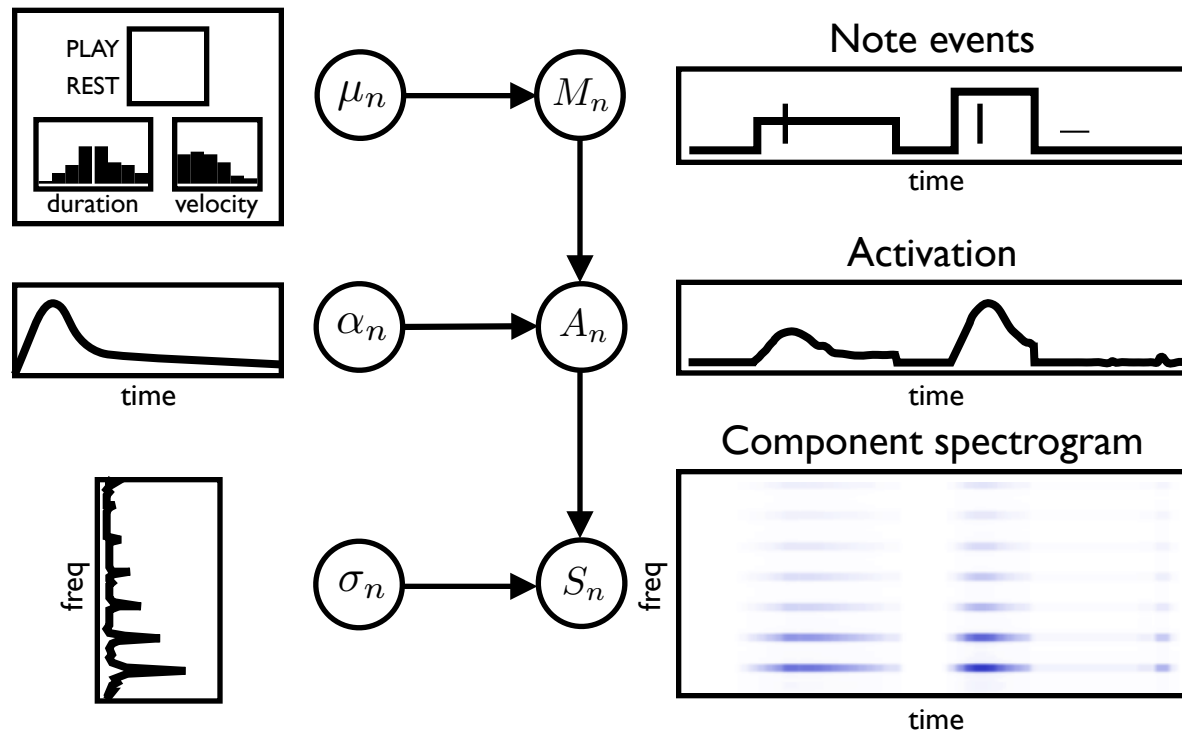

Generative Model

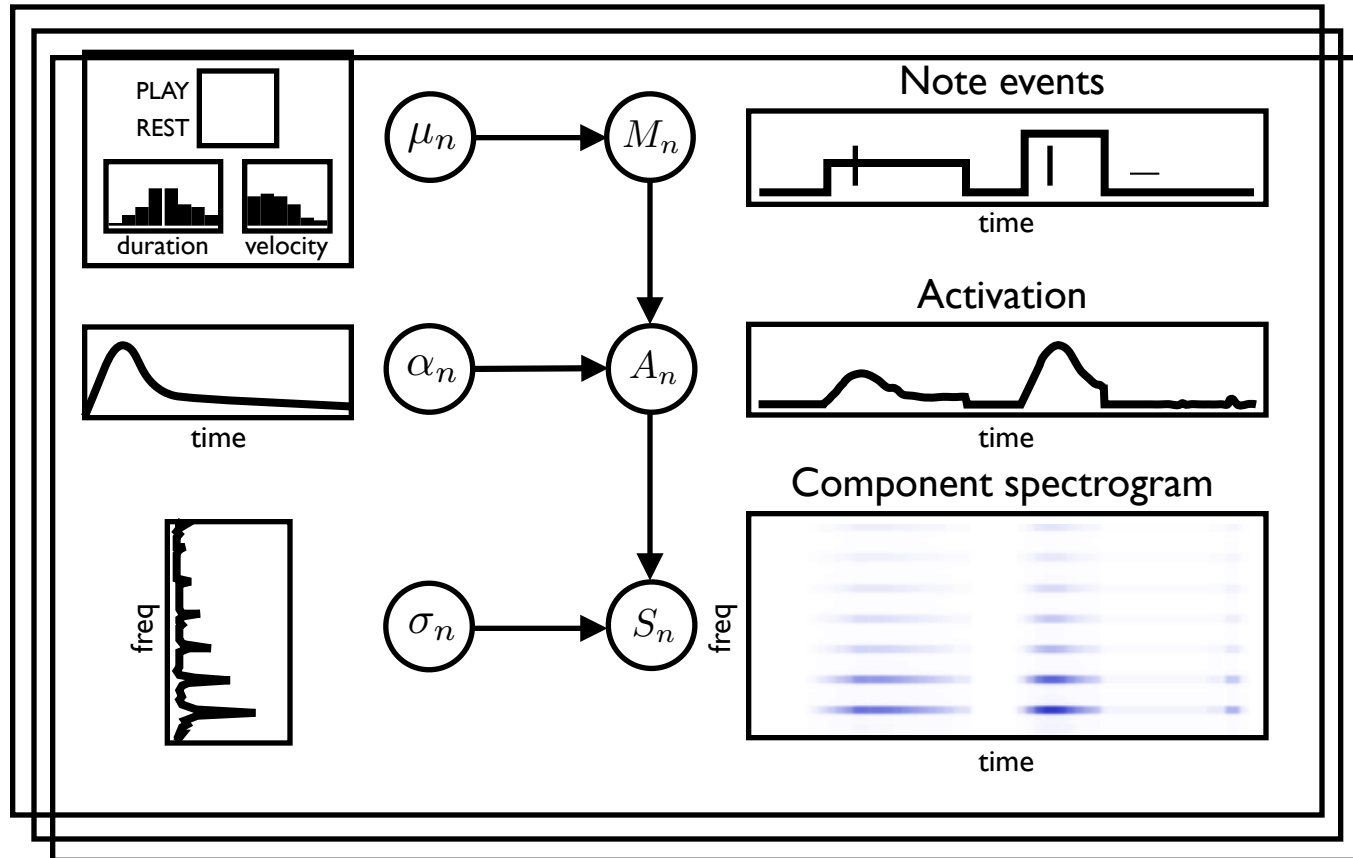

Generative Model

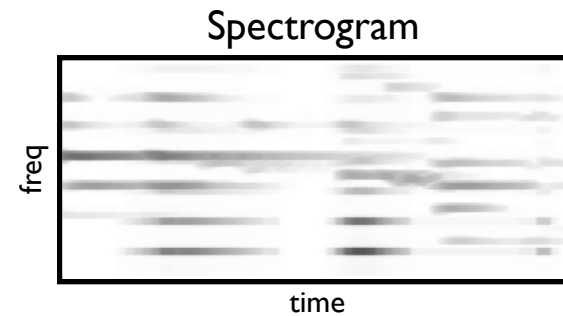
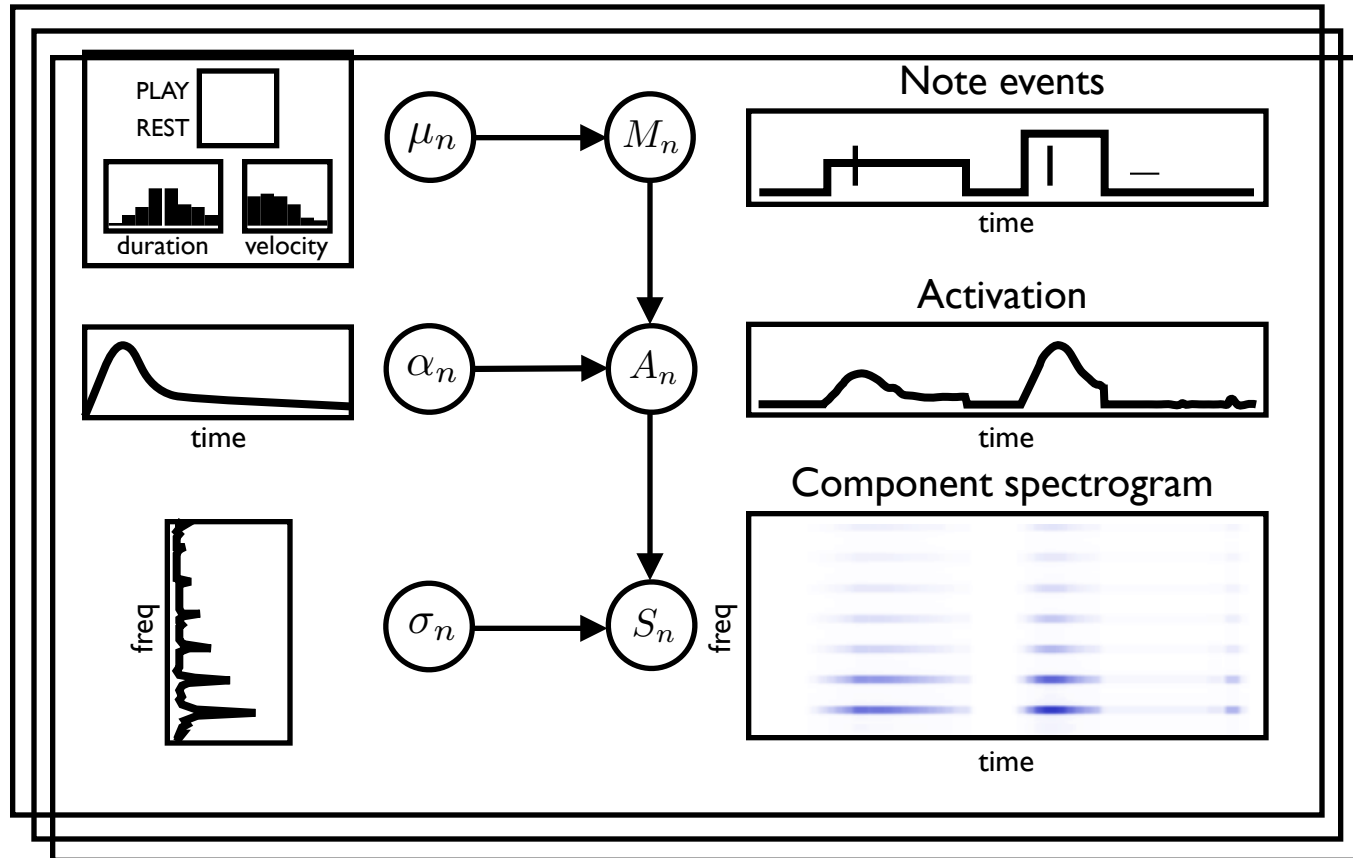

Generative Model

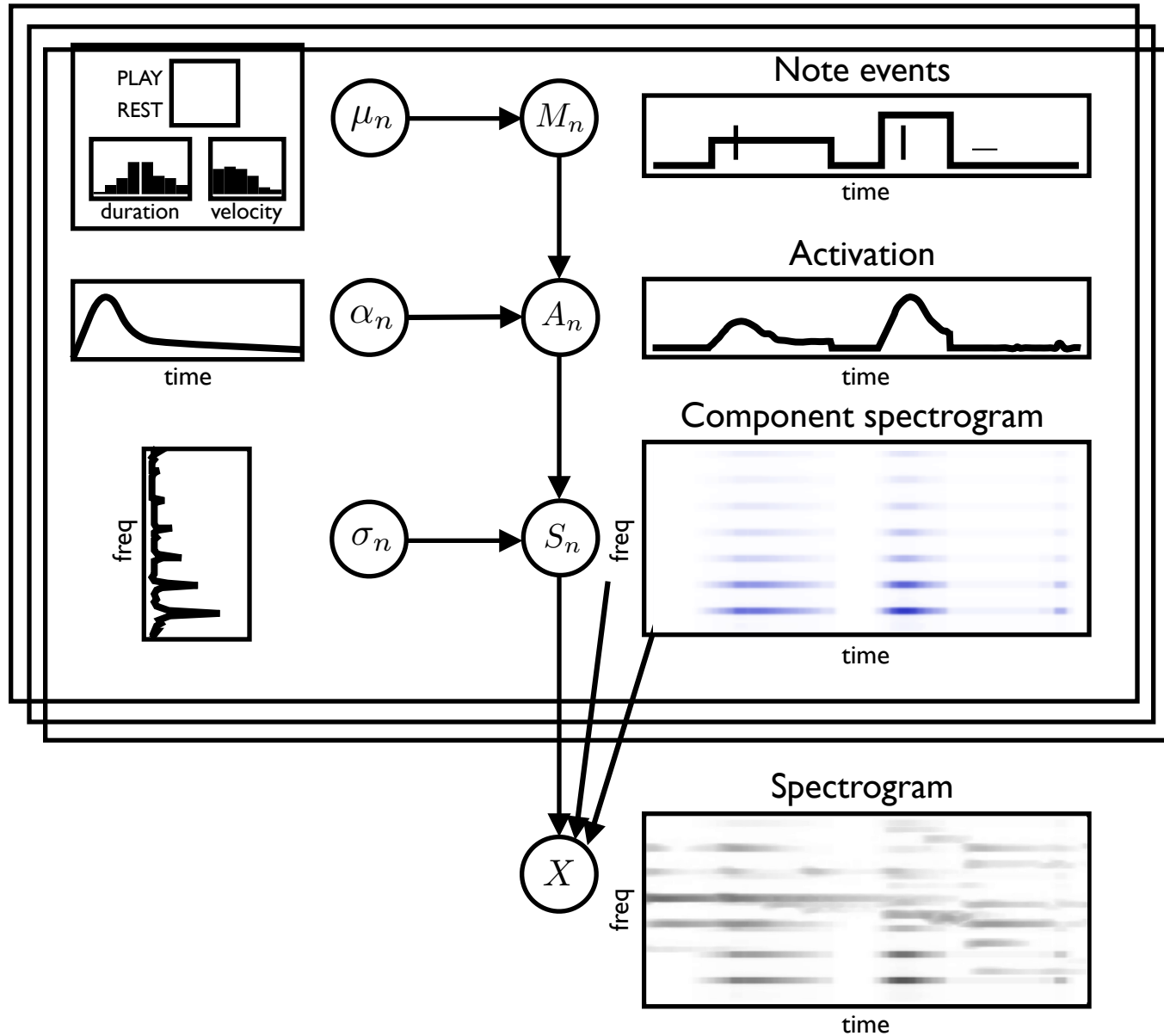

Generative Model

Latent variables

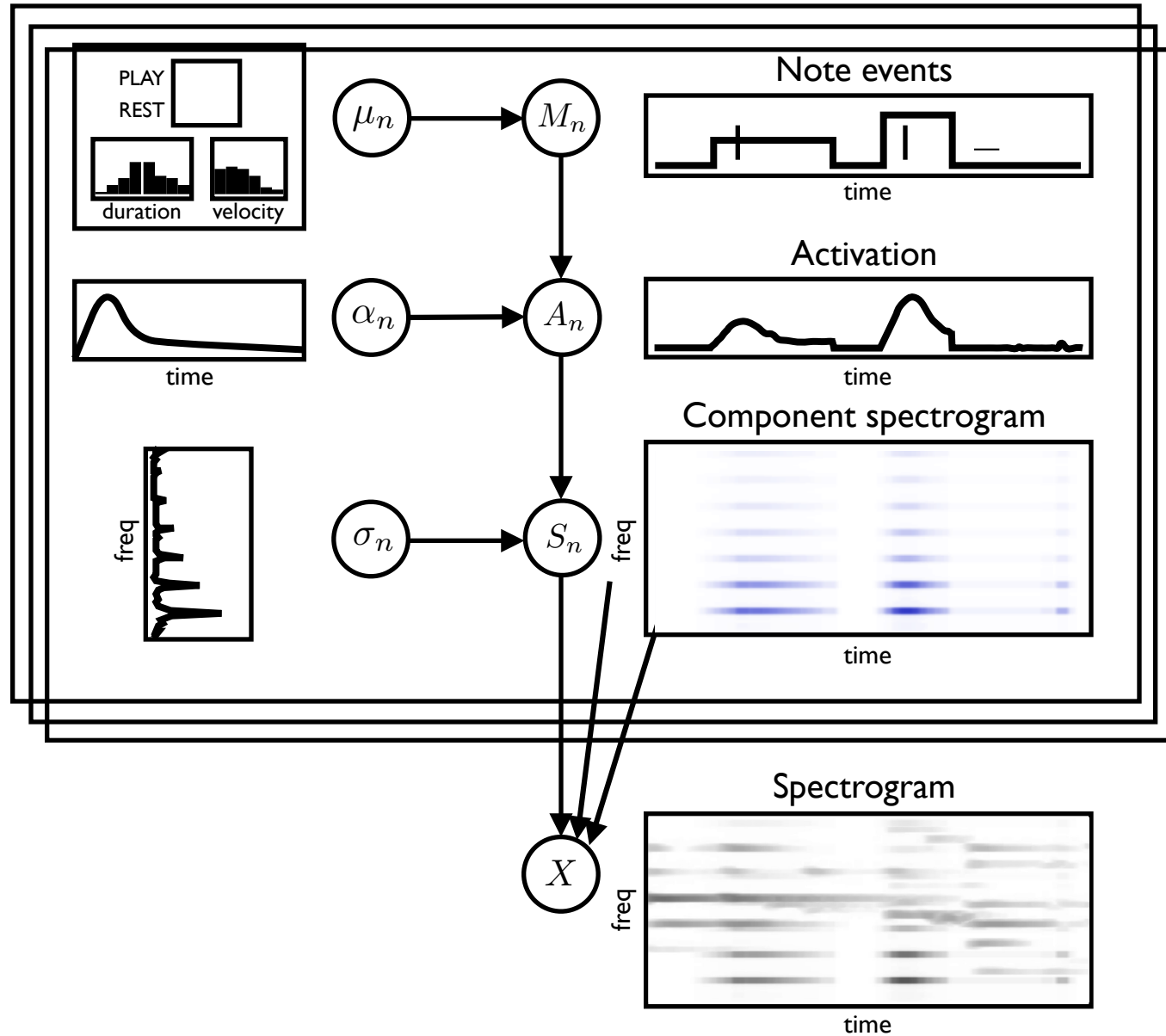

Generative Model

Parameters

Latent variables

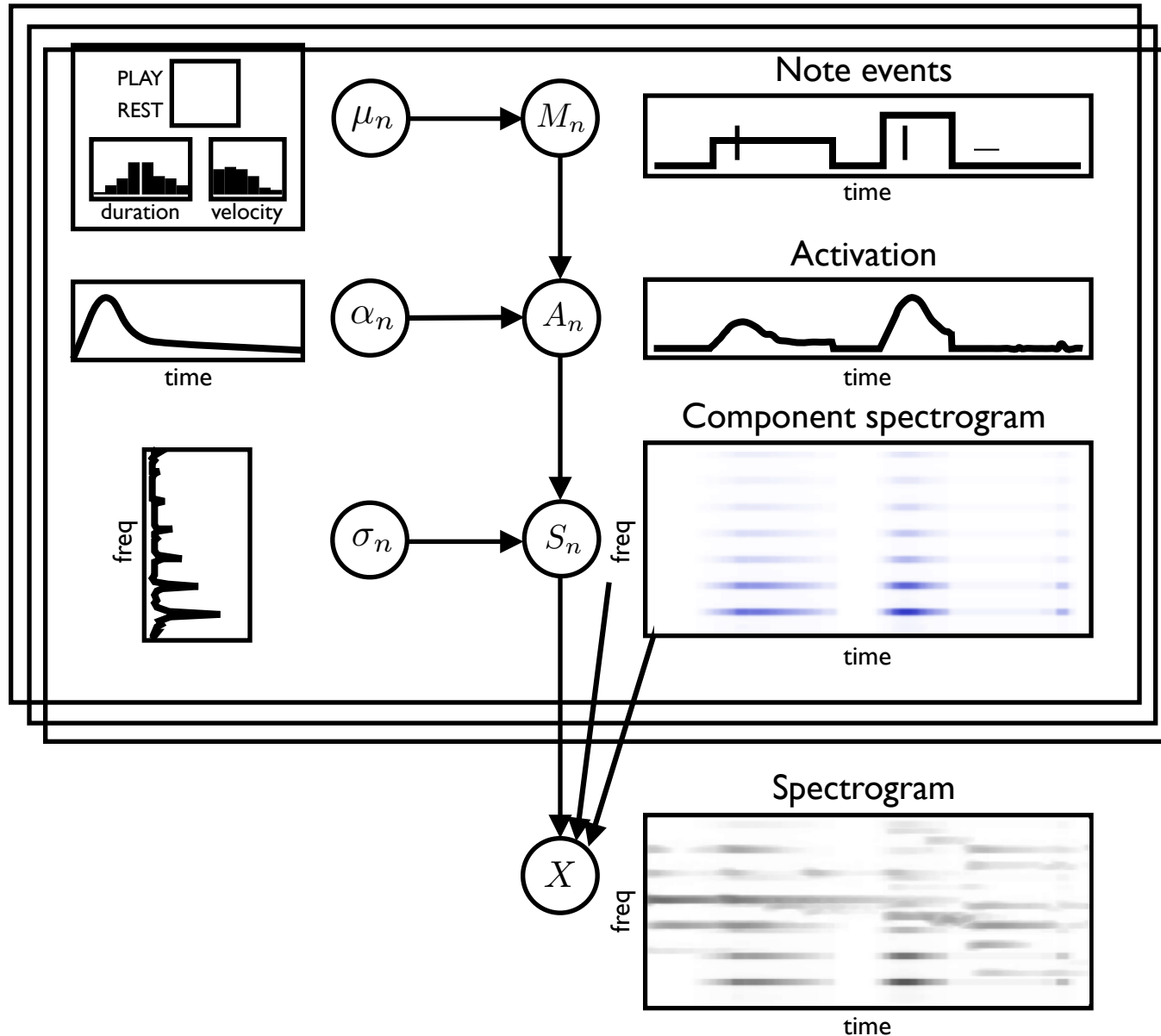

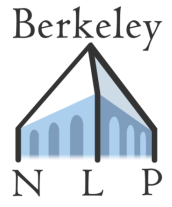

Note Event Model



Note Event Model

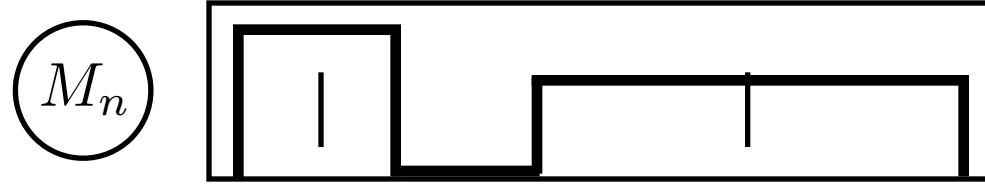

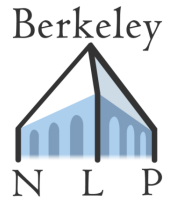

Note Event Model

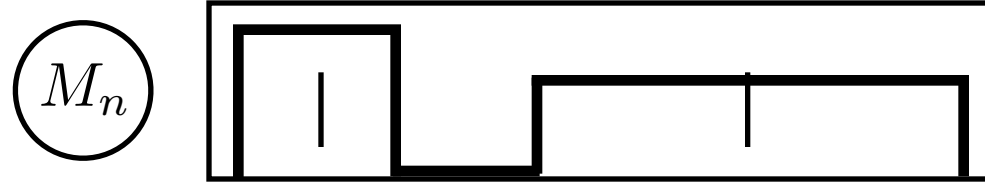

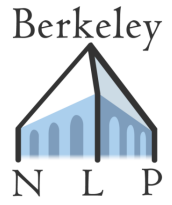

Note Event Model

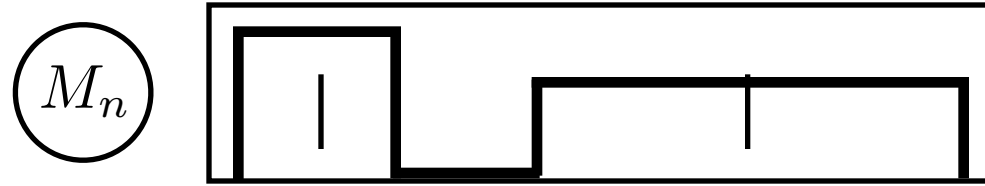

Event type

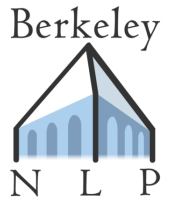

Note Event Model

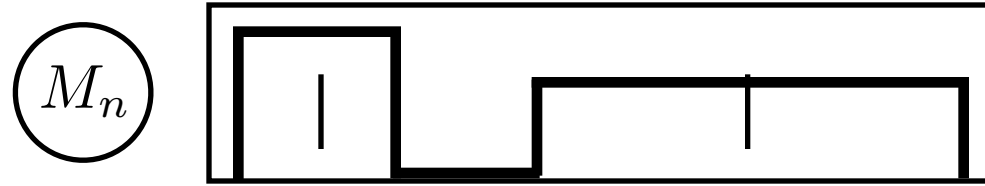

Event type

PLAY



Note Event Model

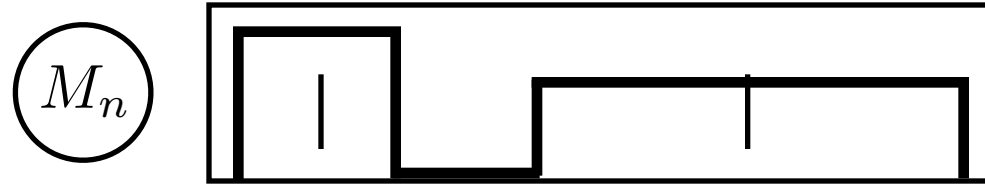

Event type

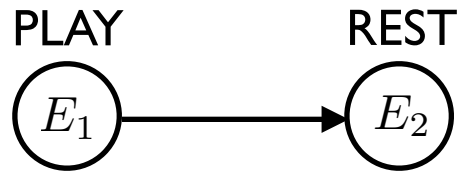

Note Event Model

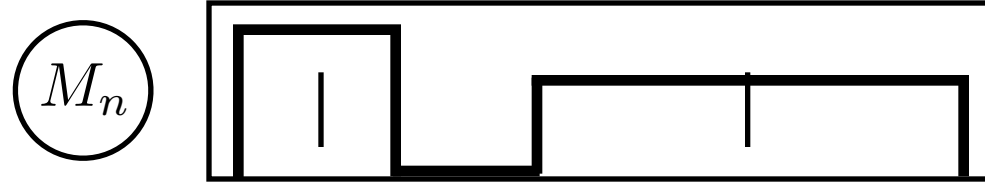

Event type

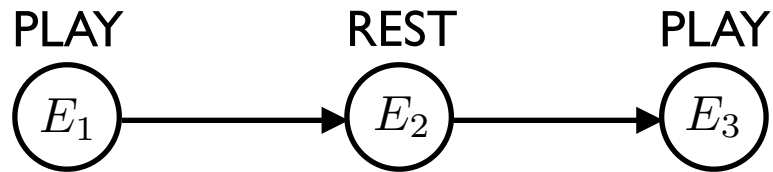

Note Event Model

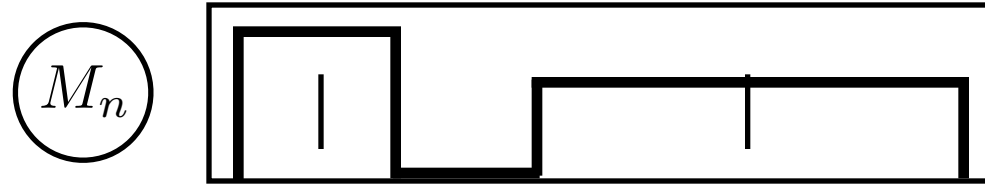

Event type

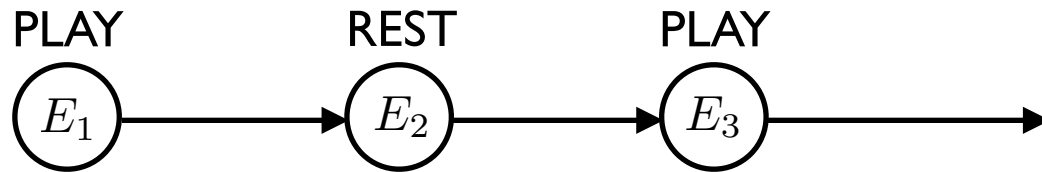

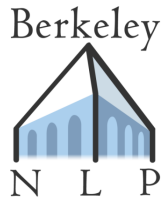

Note Event Model

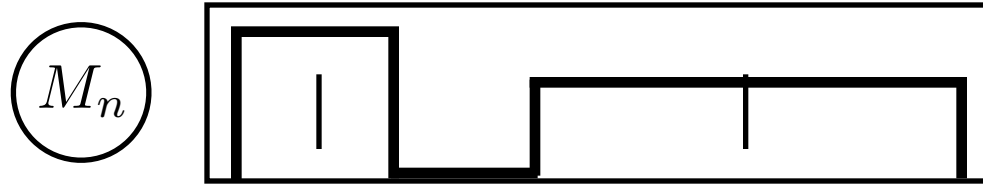

Event type

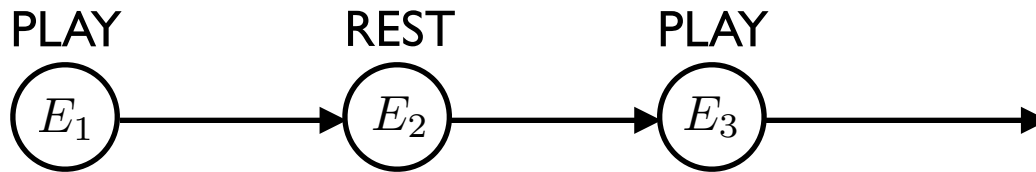

Note Event Model

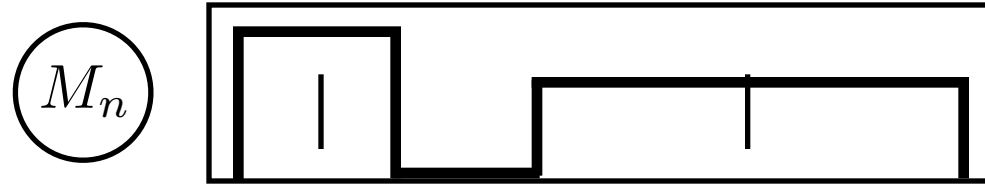

Event type

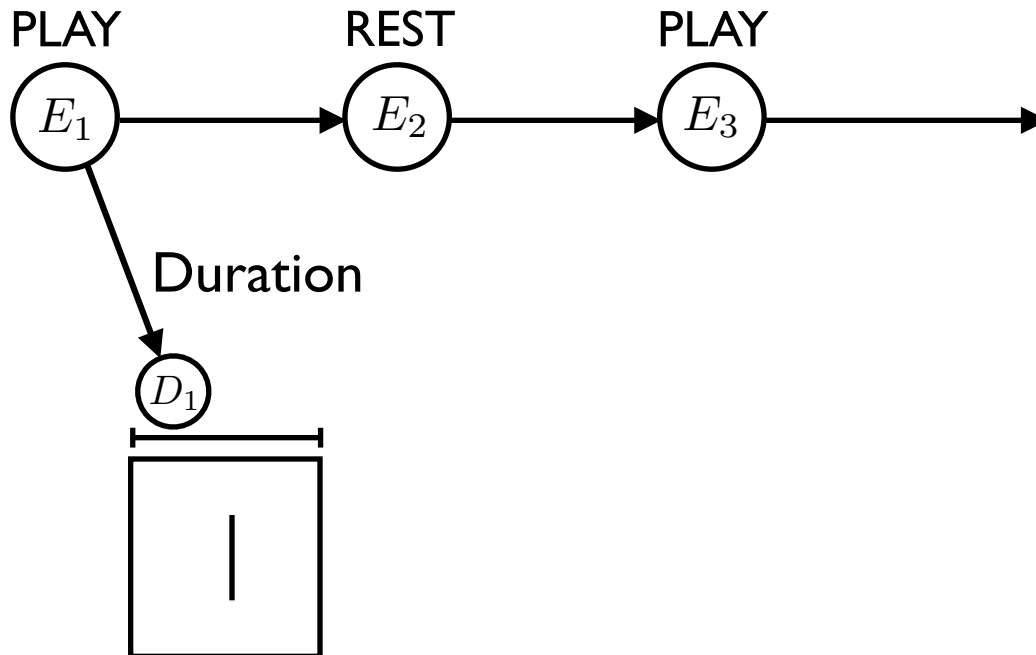

Note Event Model

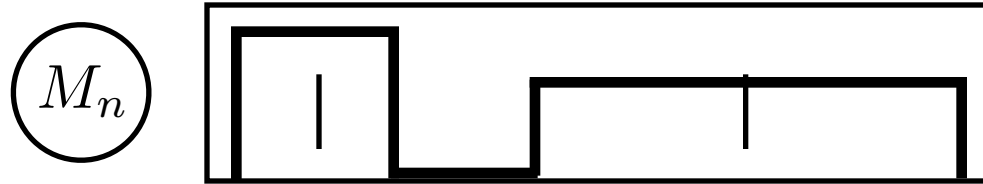

Event type

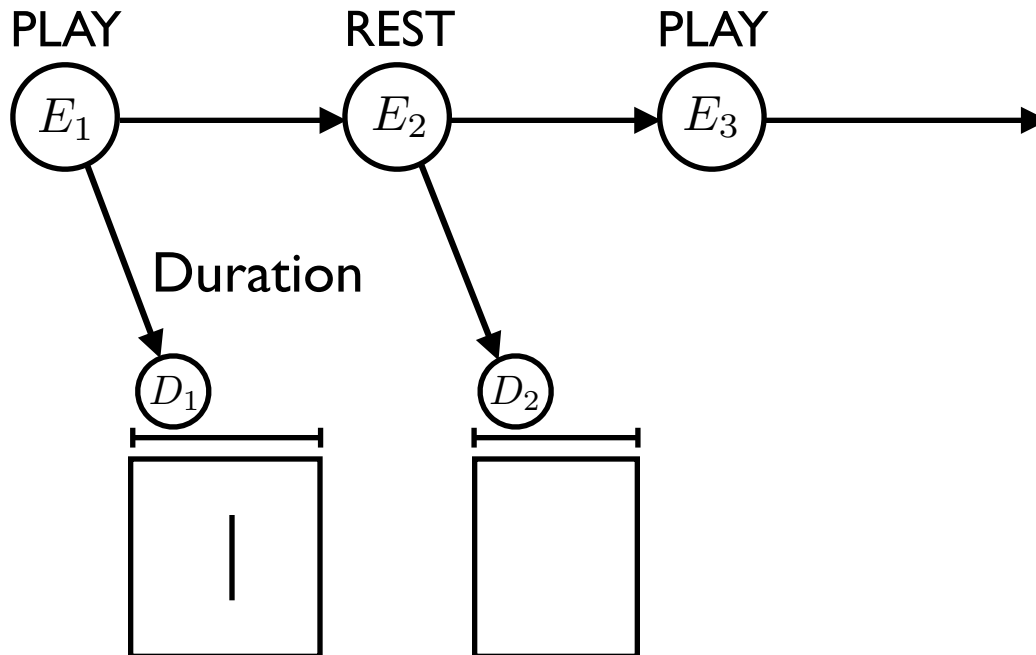

Note Event Model

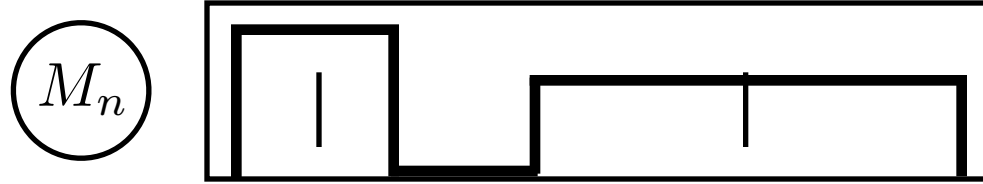

Event type

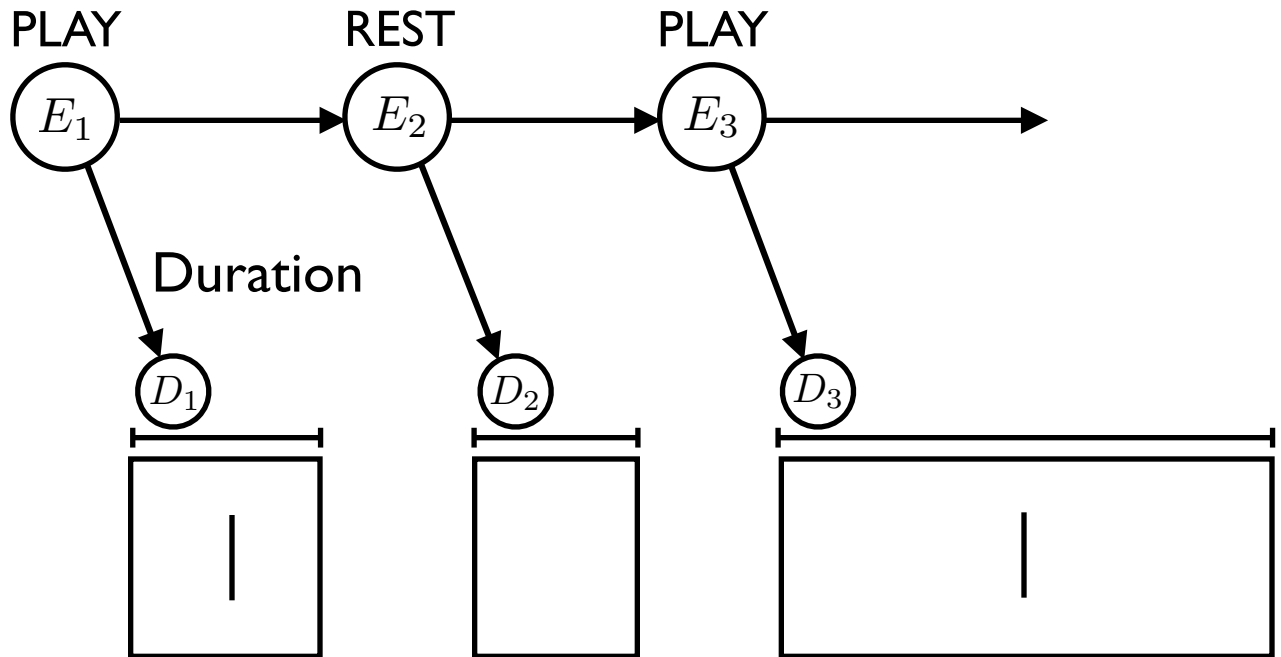

Note Event Model

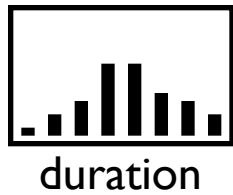
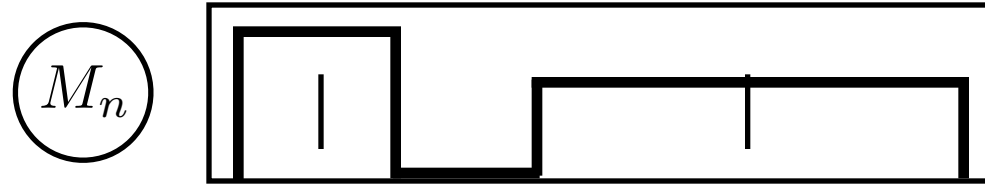

Event type

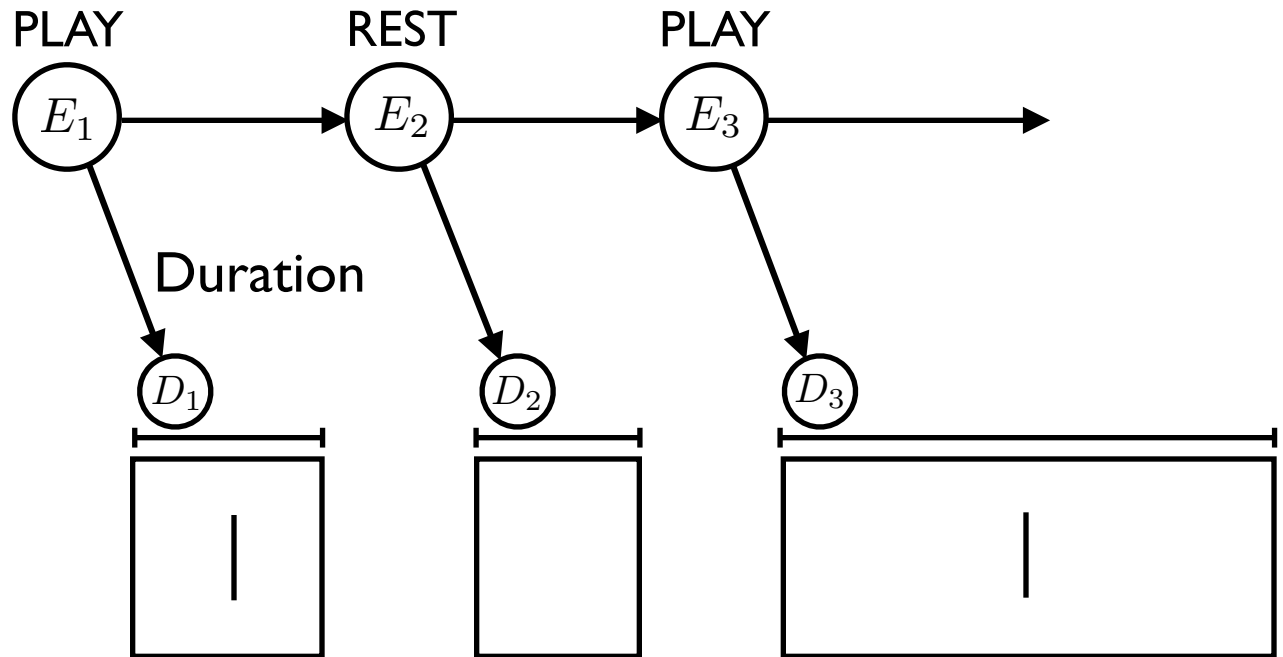

Note Event Model

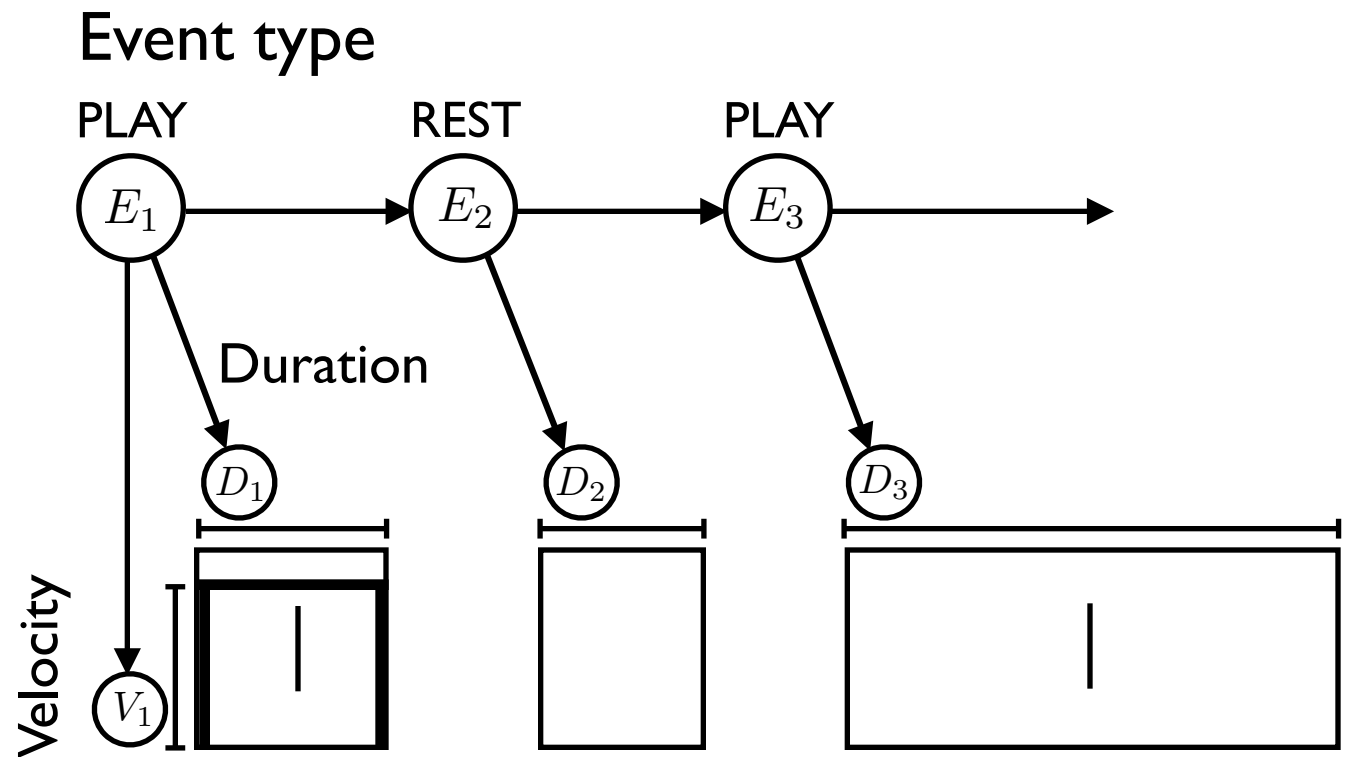
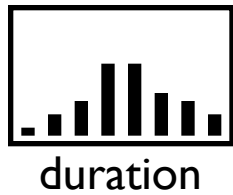
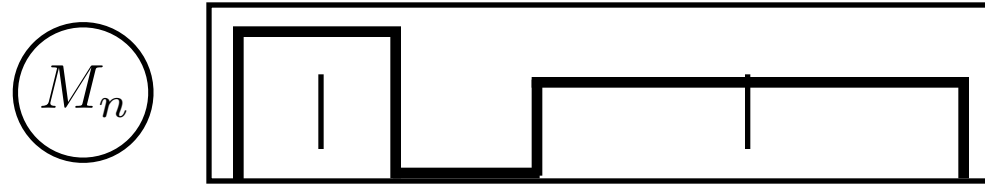

Note Event Model

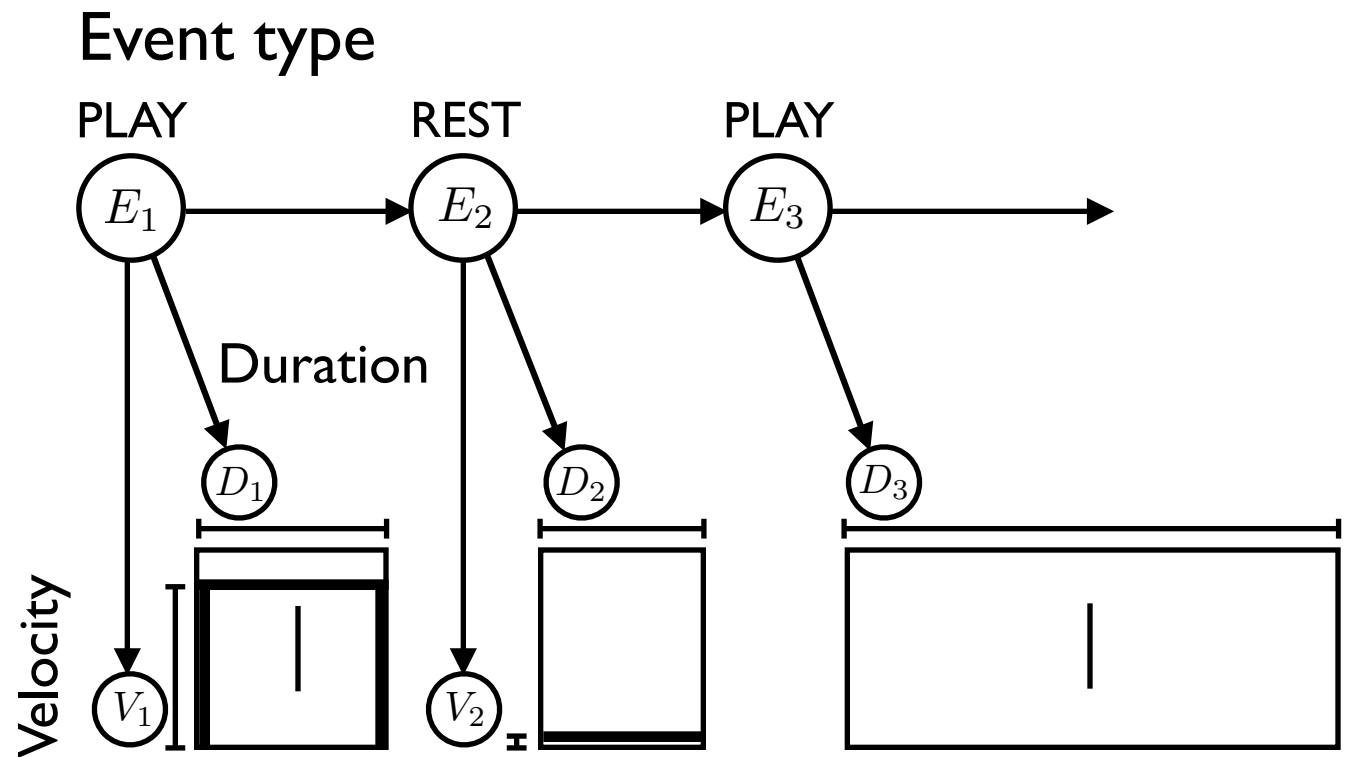
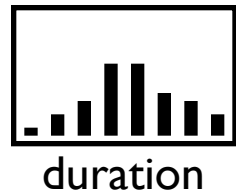
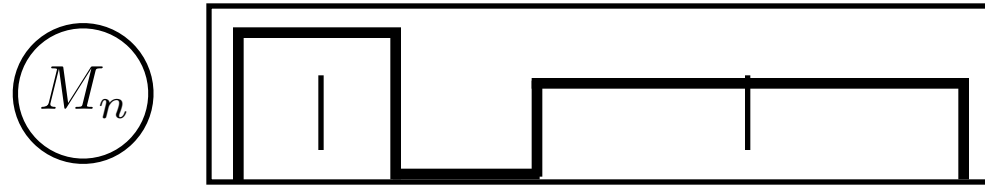

Note Event Model

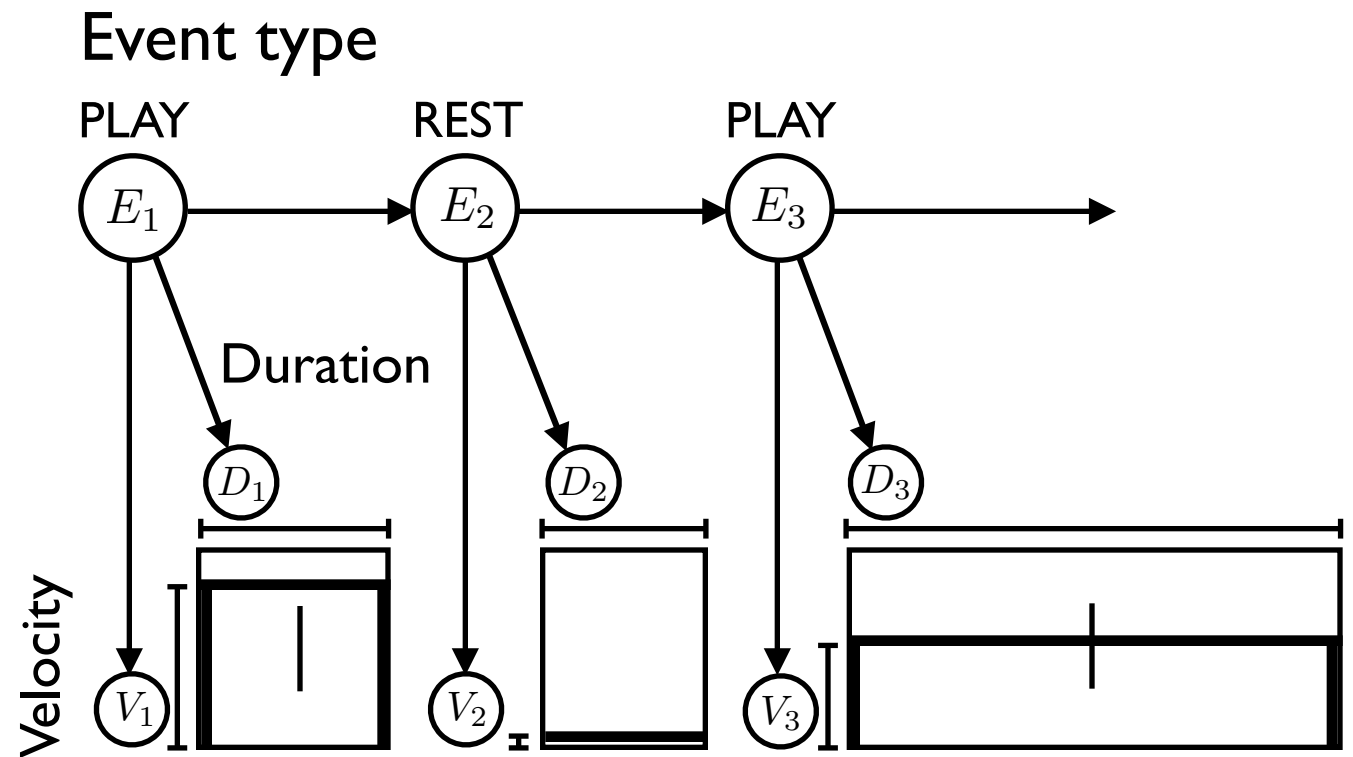
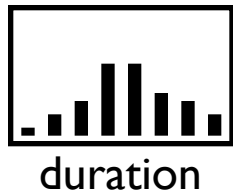
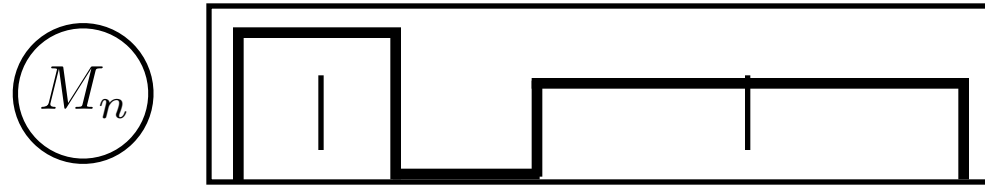

Note Event Model

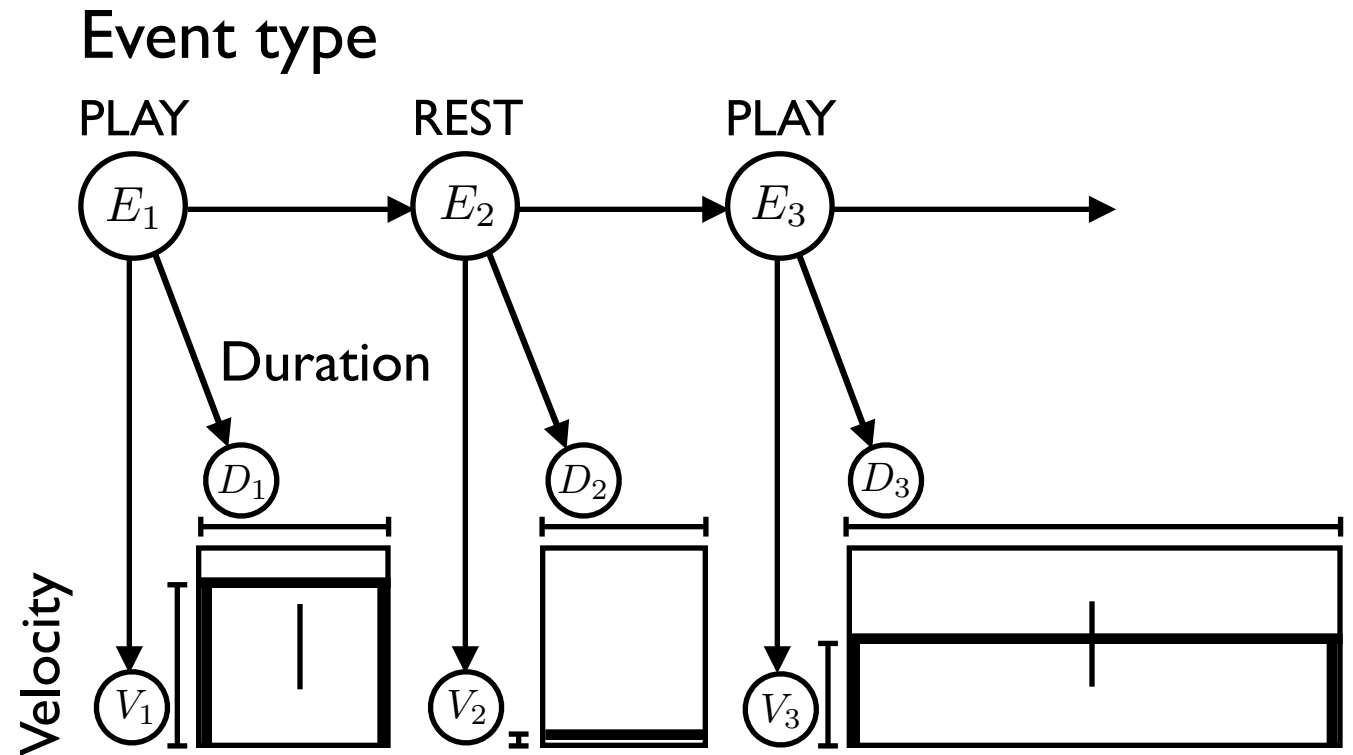
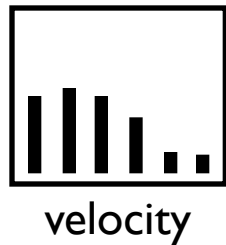
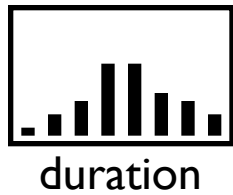
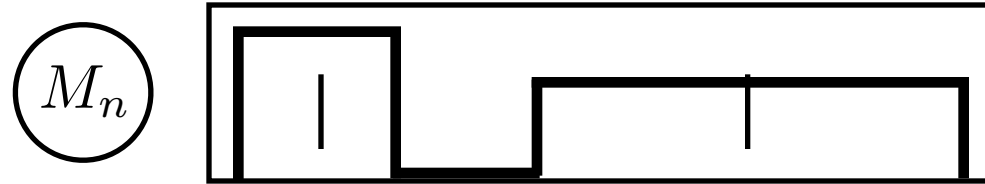

Note Event Model

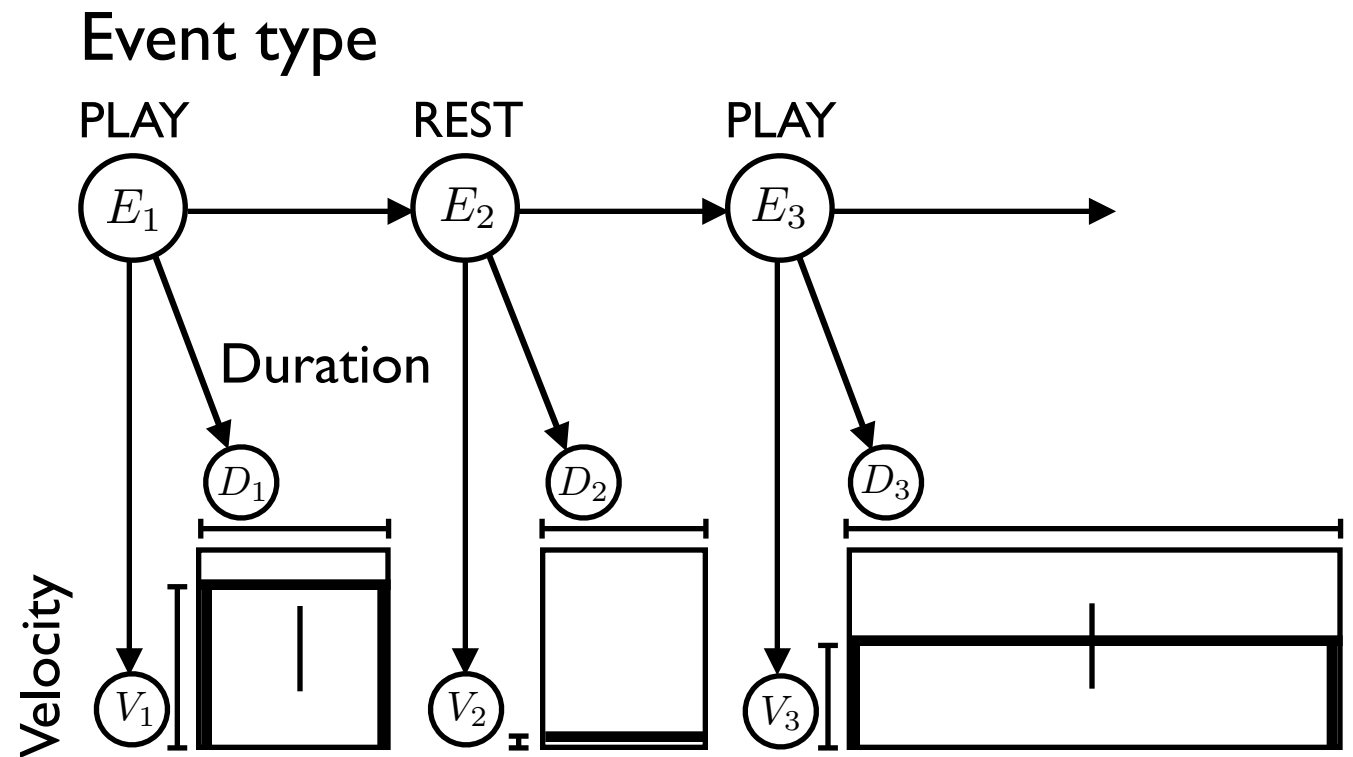
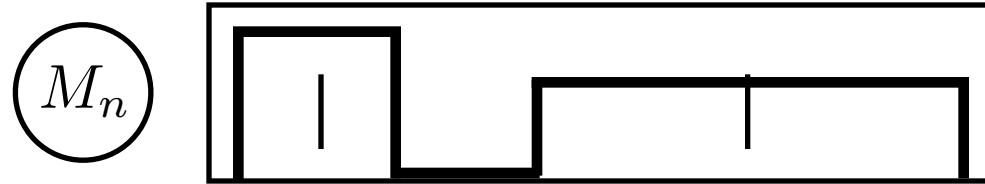
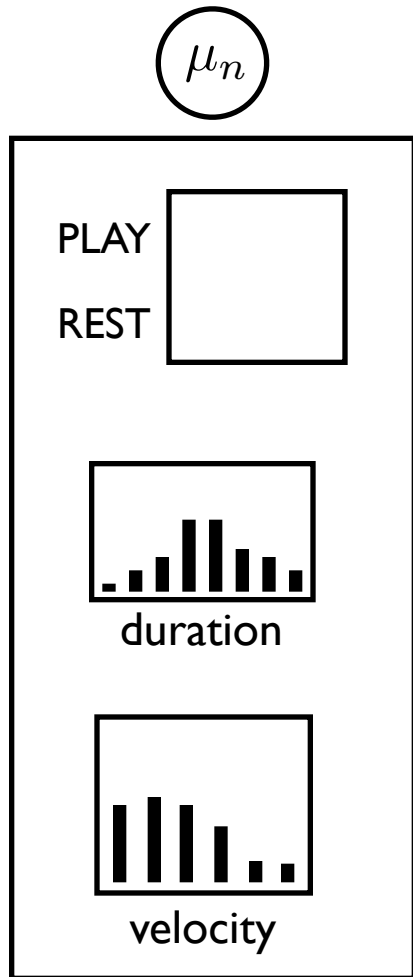

Activation Model

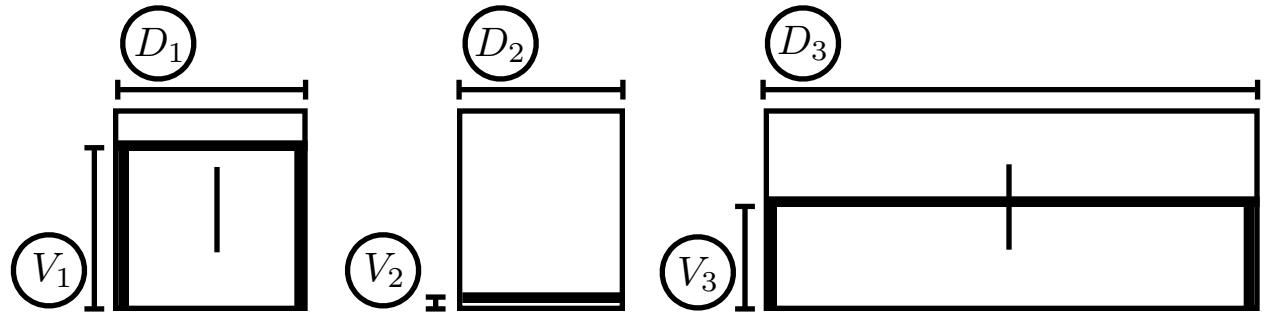

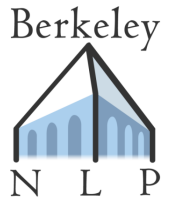

Activation Model

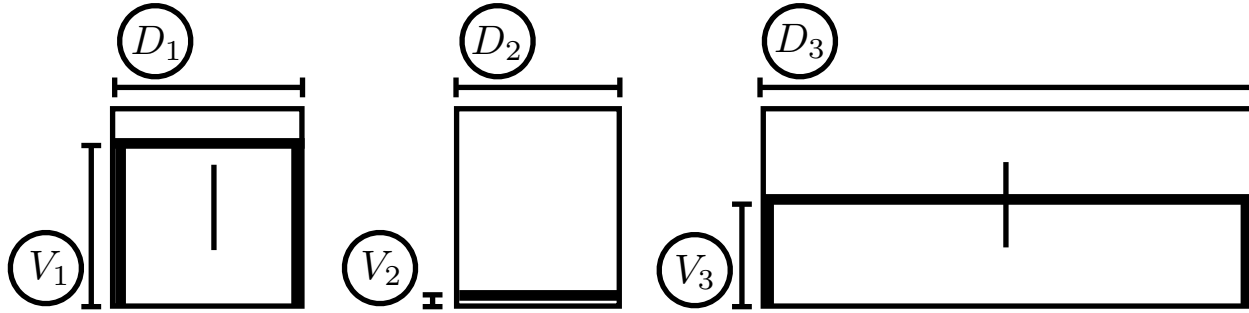

Berkeley



Activation Model

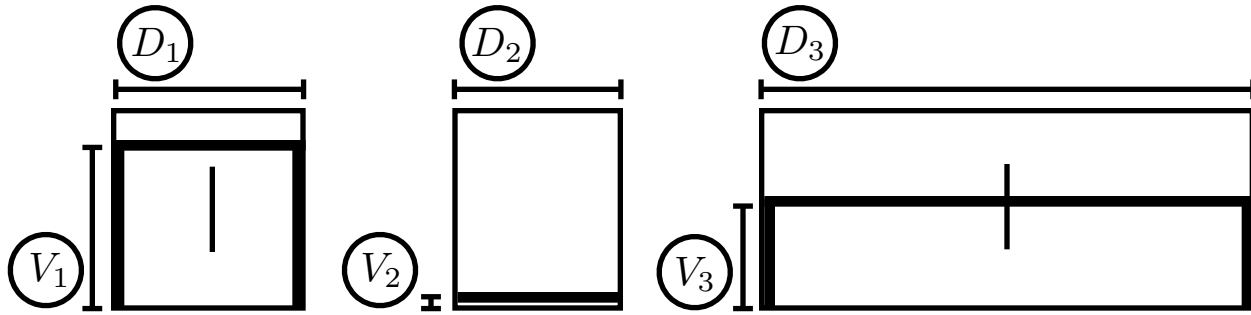

Berkeley



Activation Model

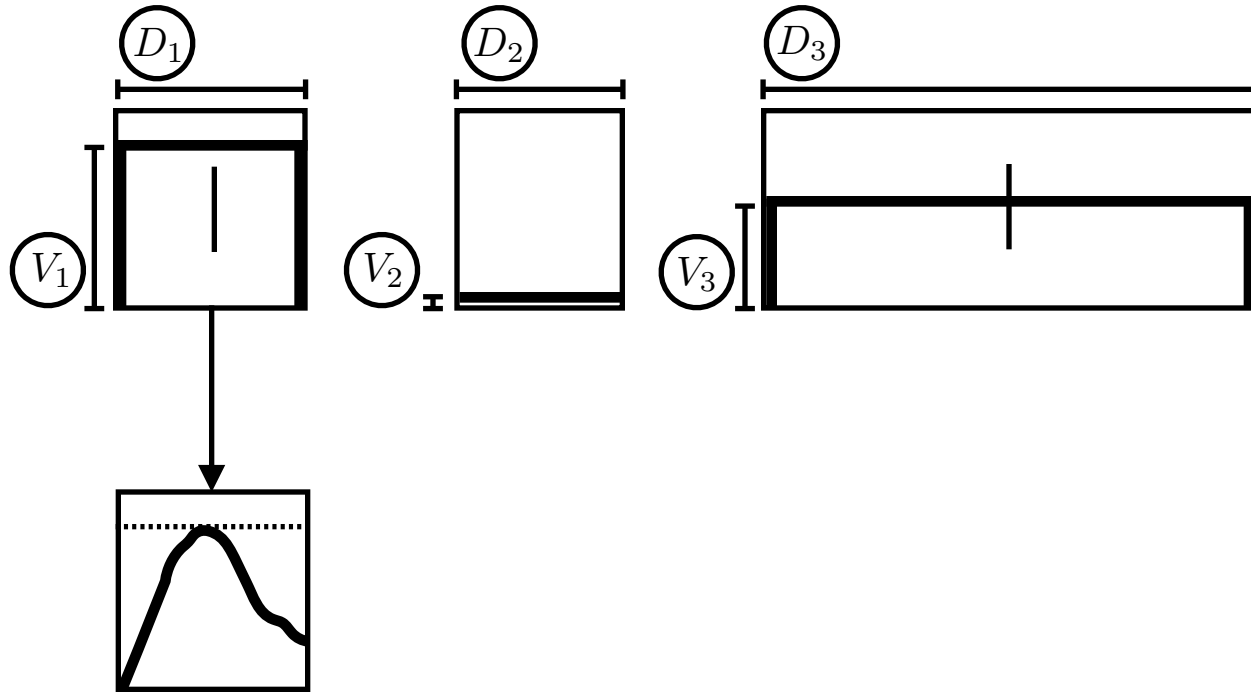

Activation Model

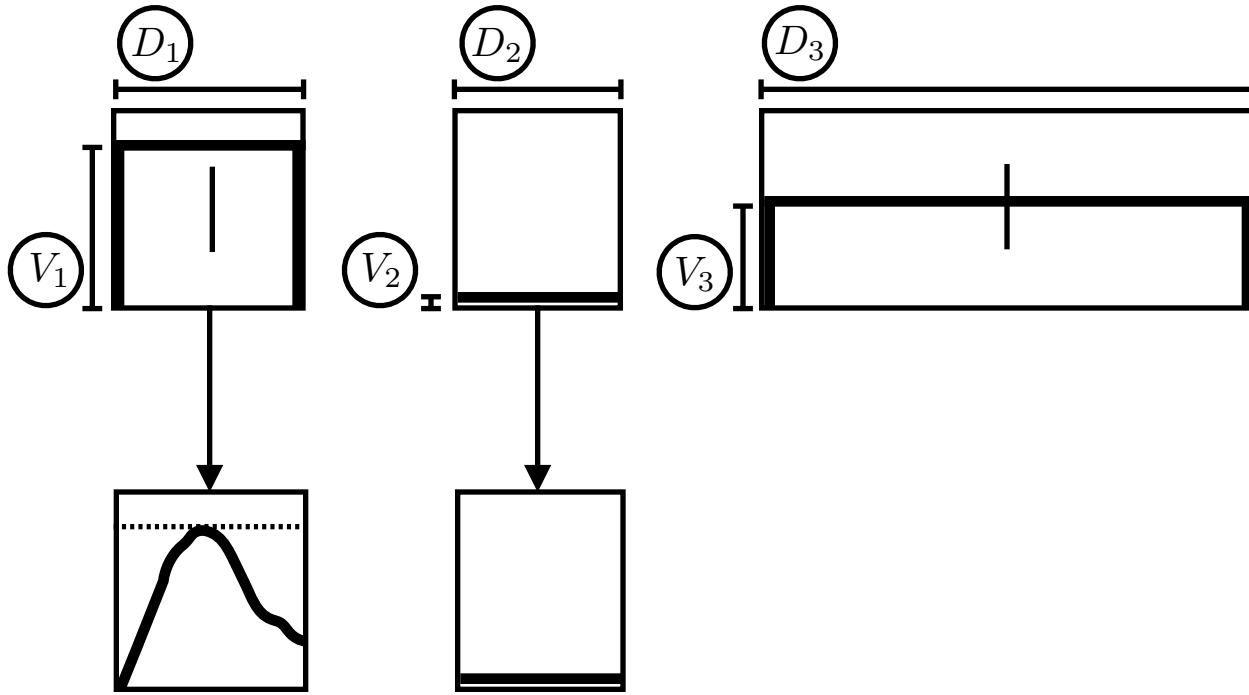

Activation Model

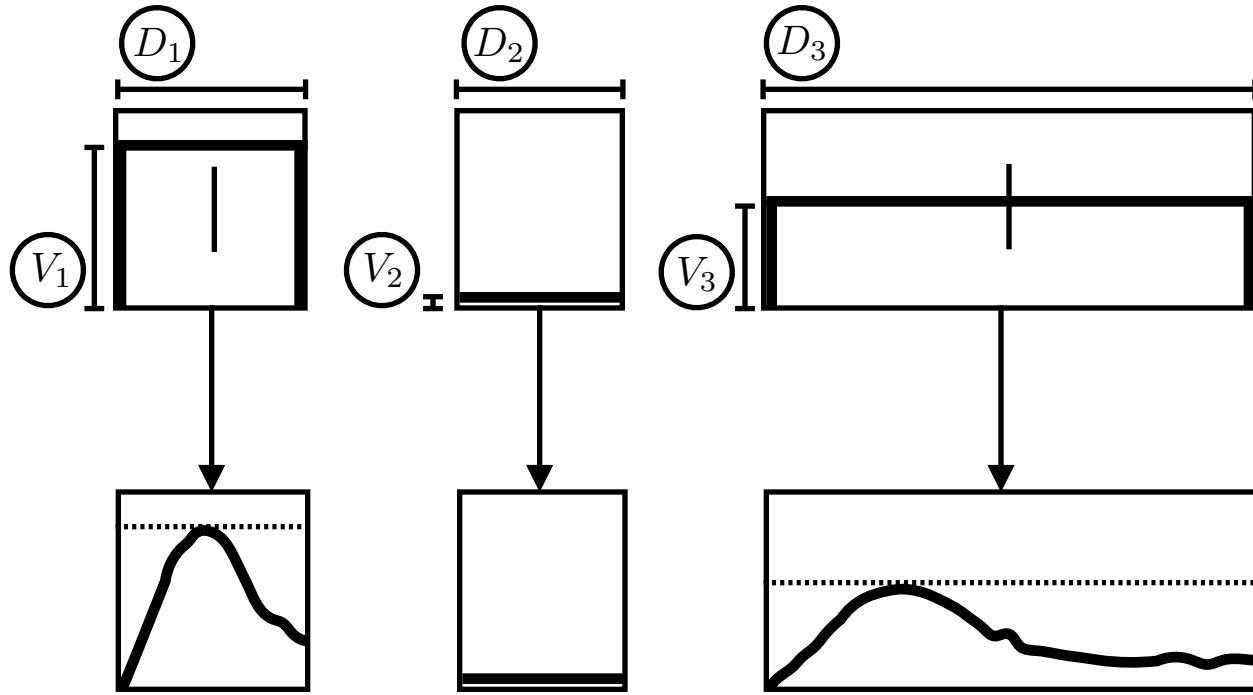

Activation Model

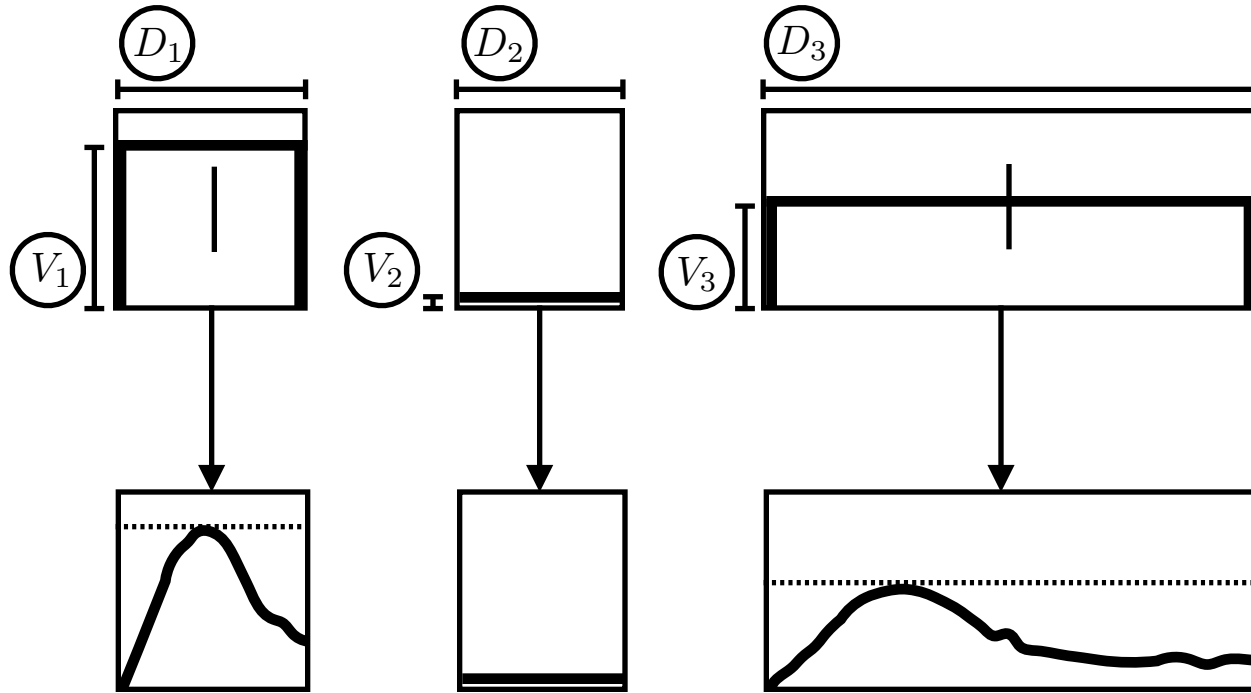

Activation





Activation Model

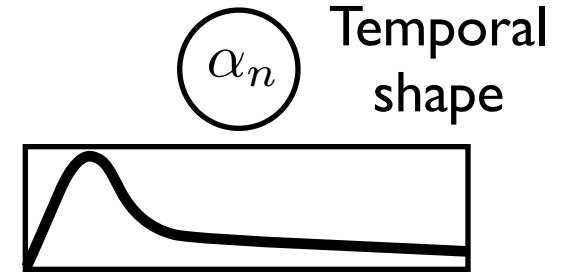
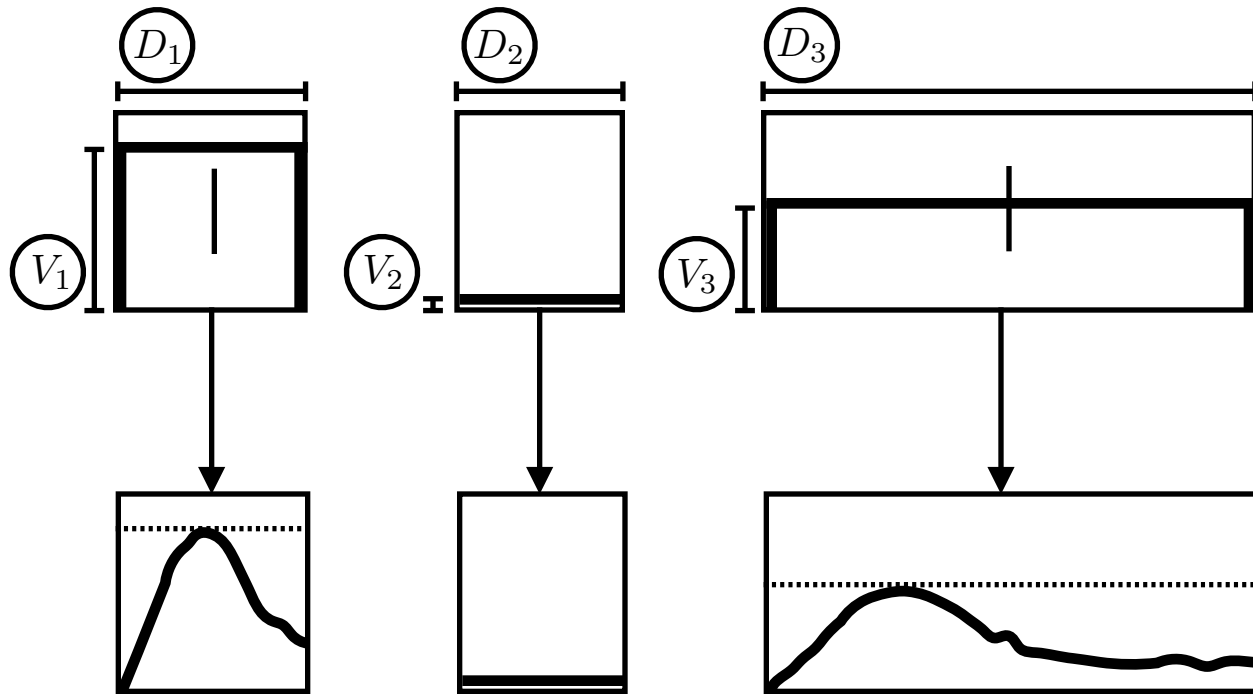

Activation





Activation Model

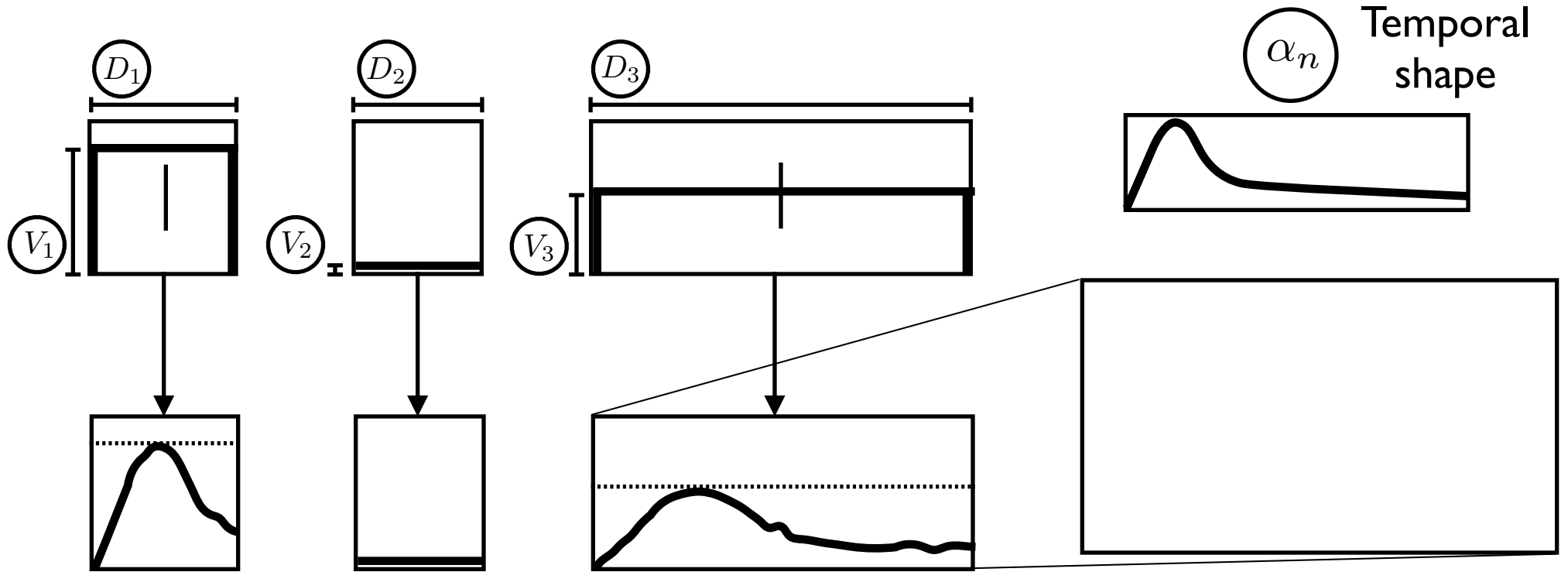

Activation

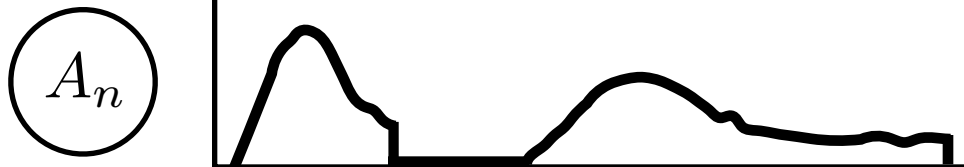



Activation Model

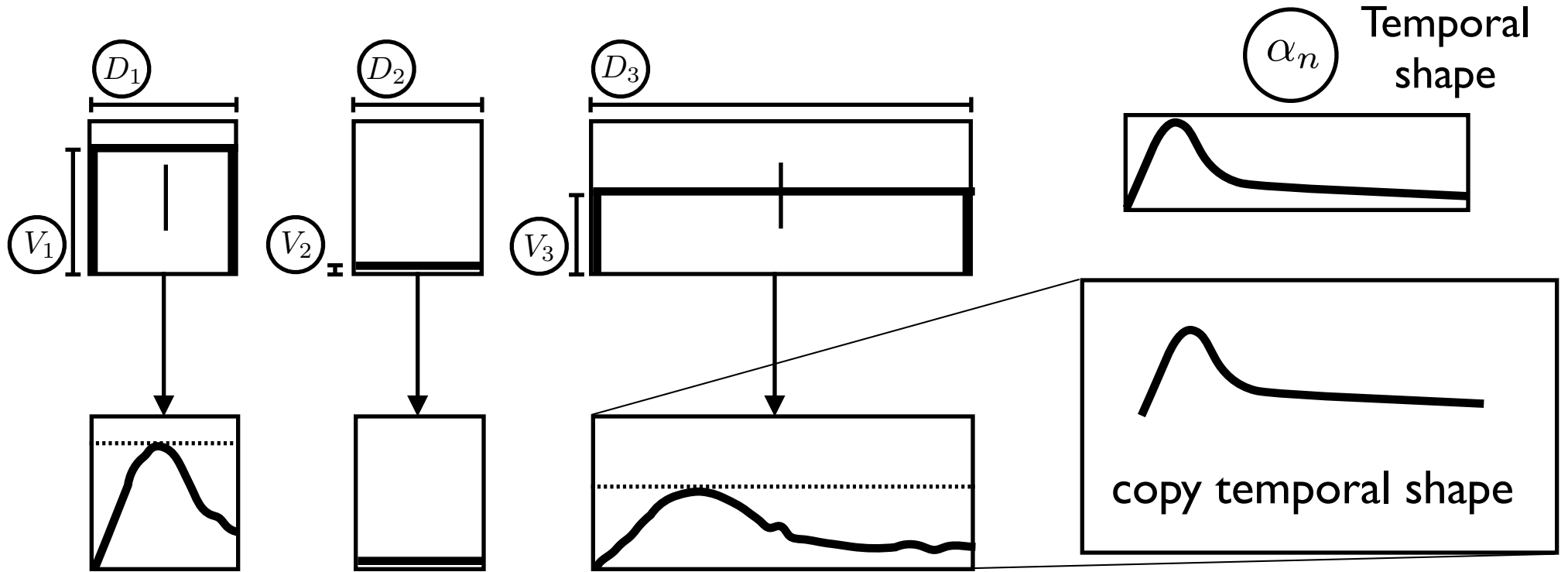

Activation

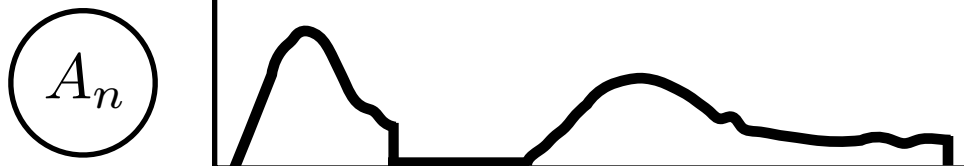



Activation Model

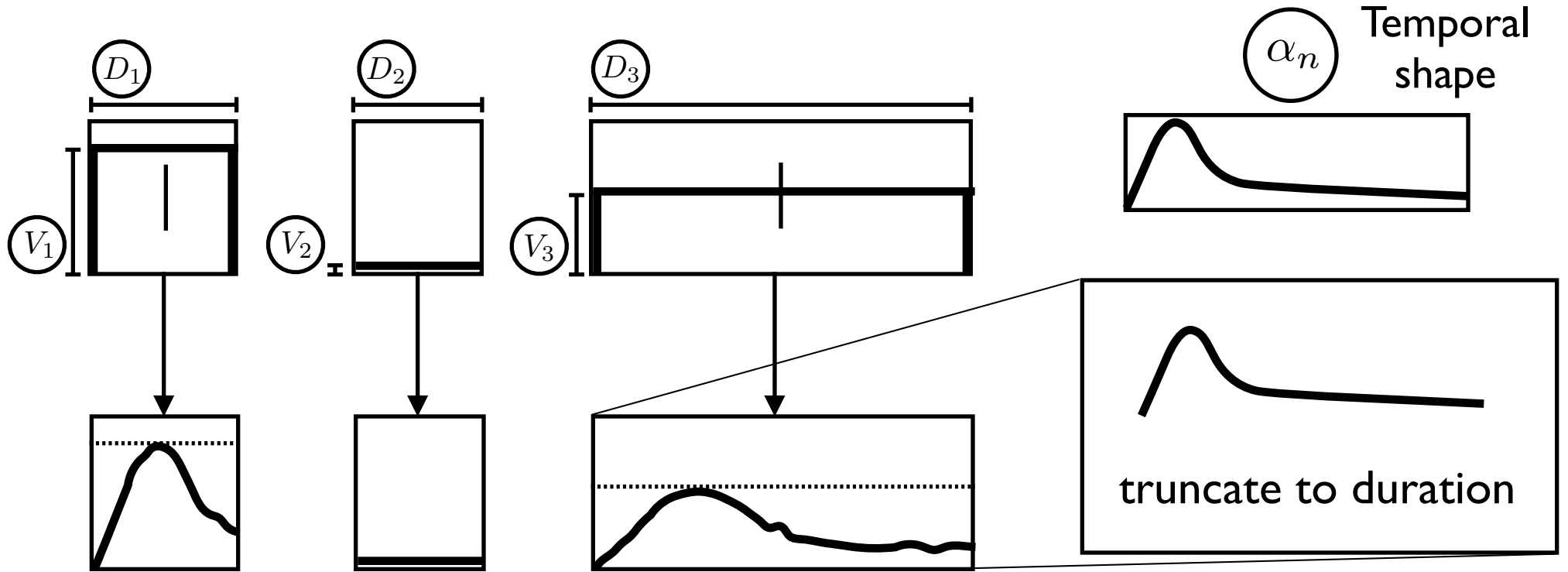

Activation

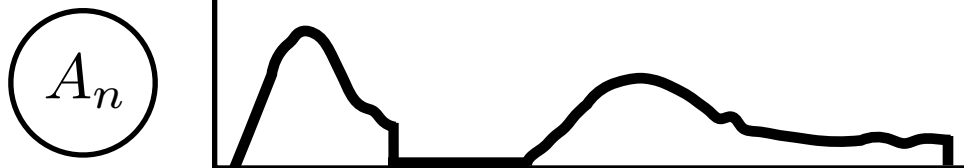



Activation Model

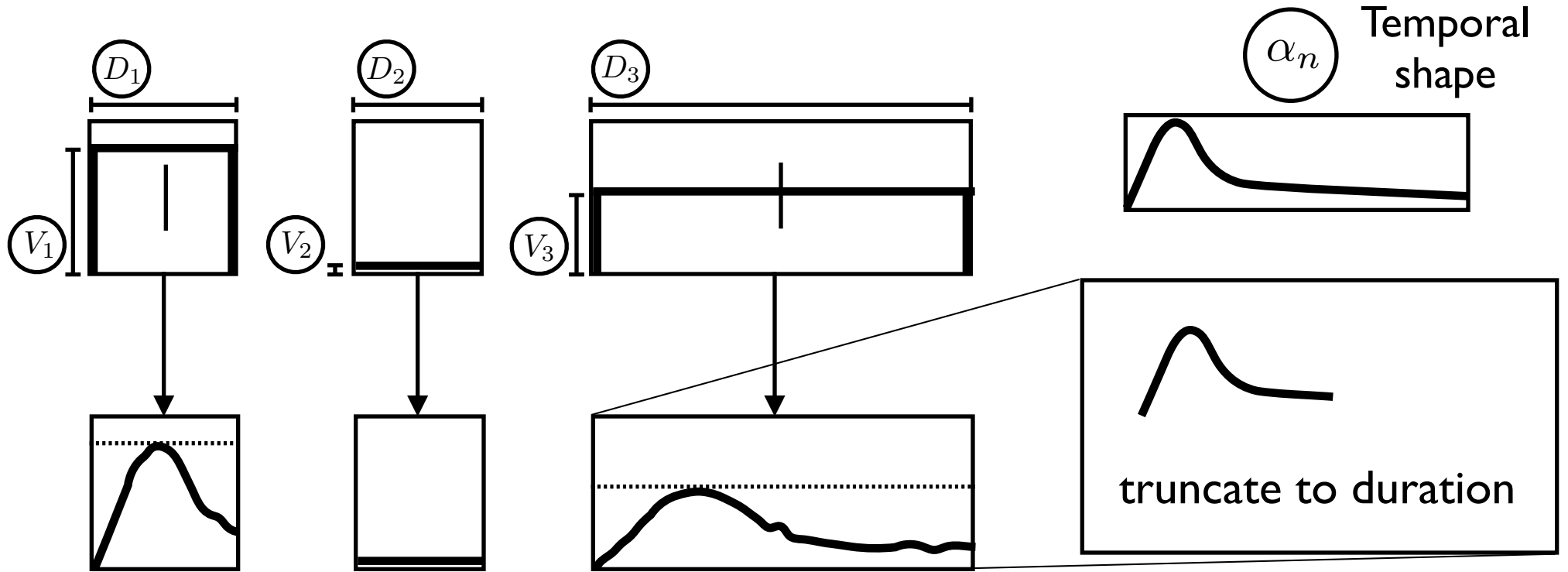

Activation

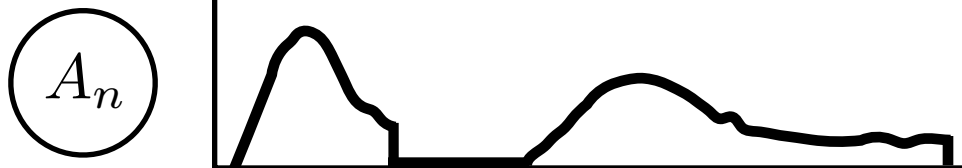



Activation Model

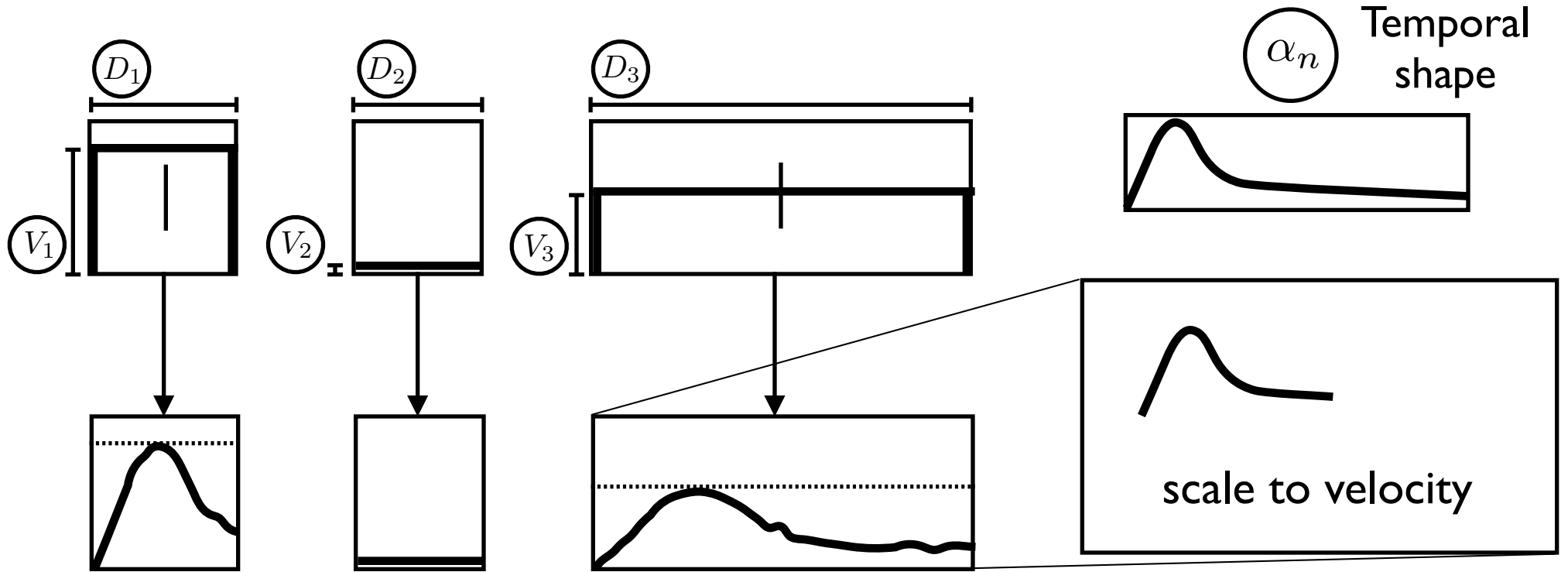

Activation

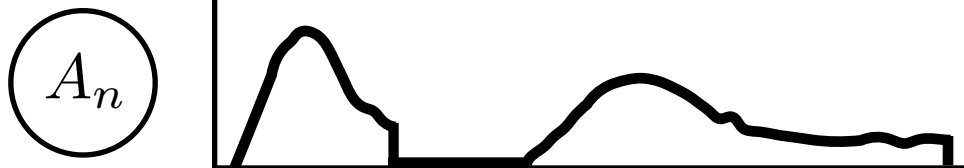



Activation Model

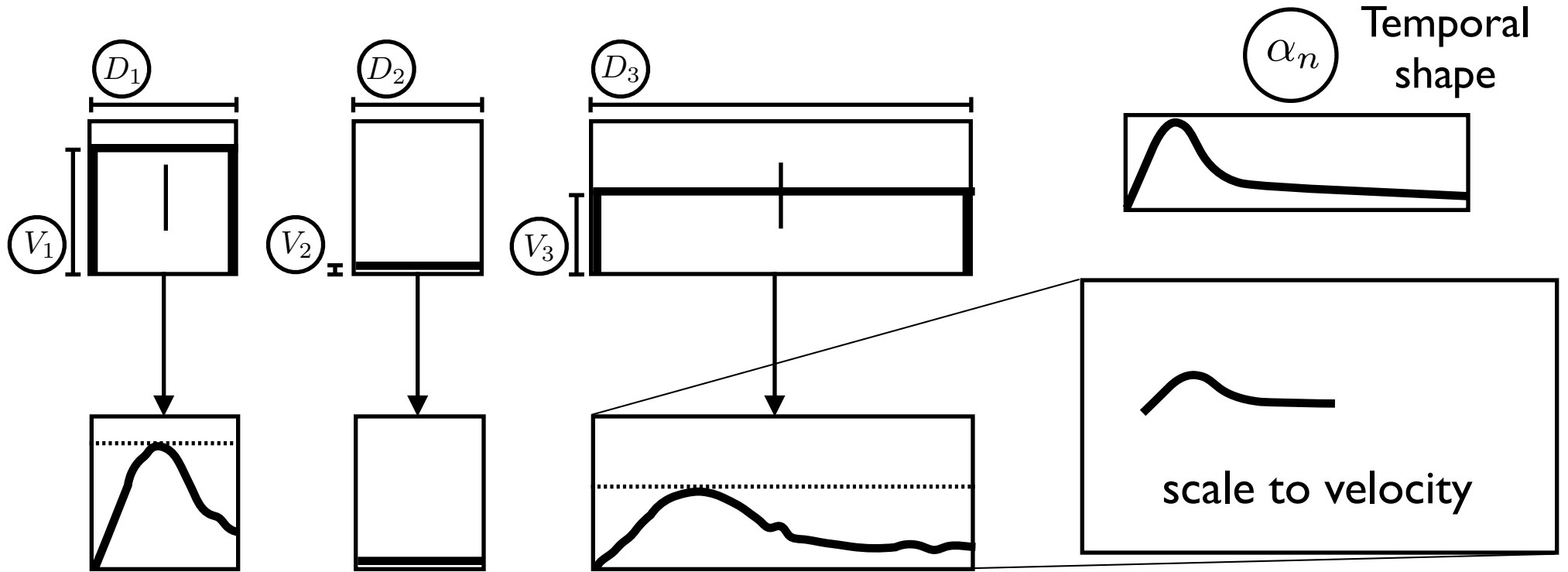

Activation





Activation Model

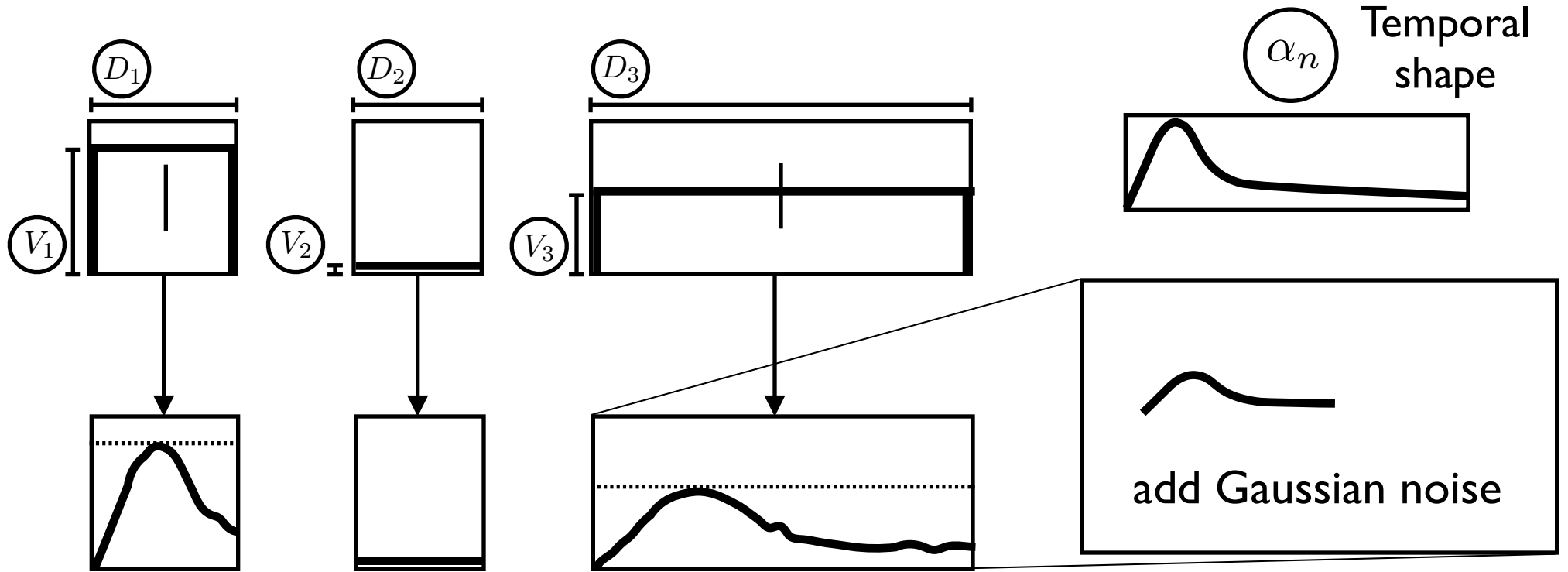

Activation

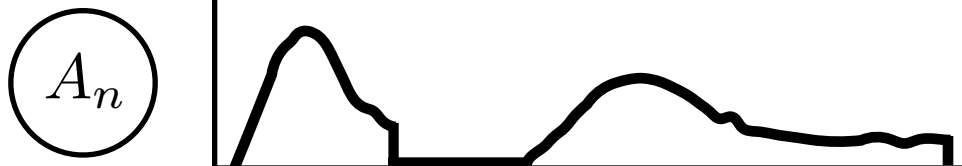



Activation Model

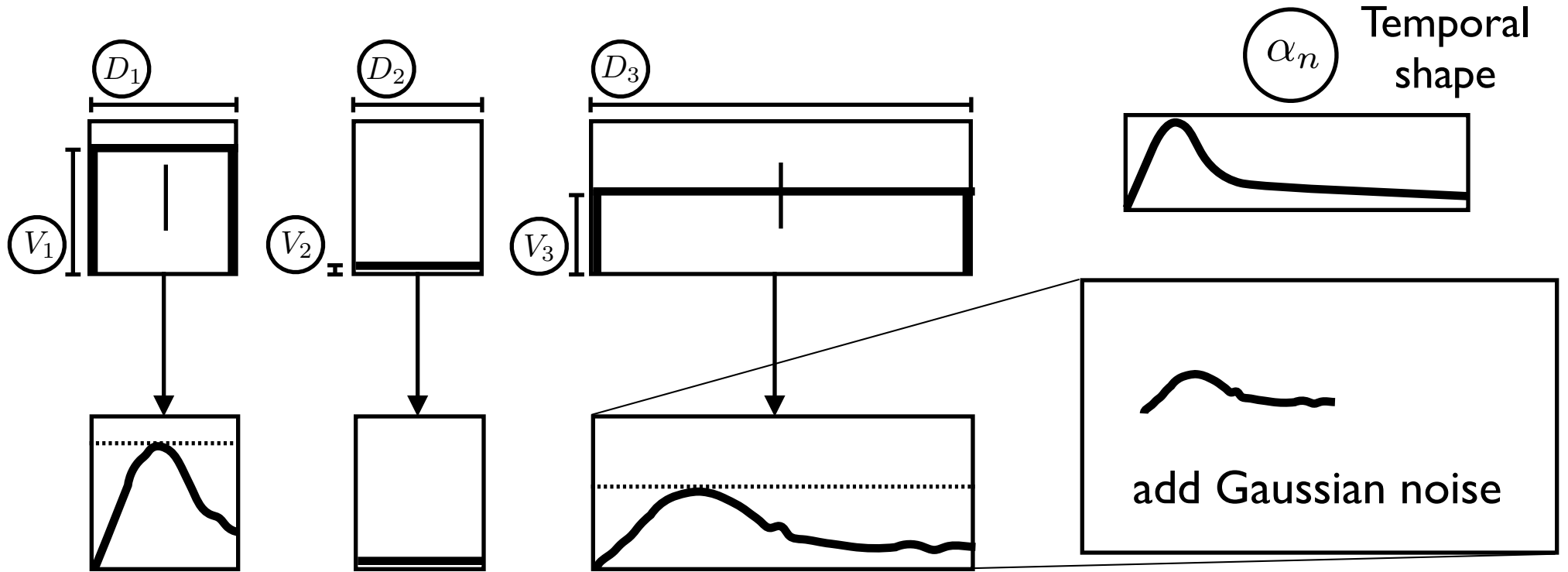

Activation



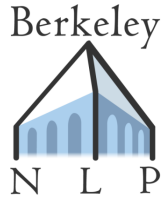

Component Spectrogram Model

Activation

A_n

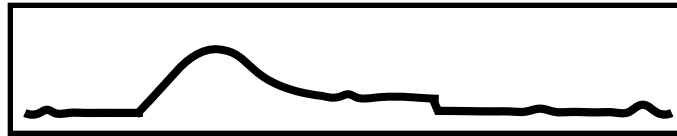

Component Spectrogram Model

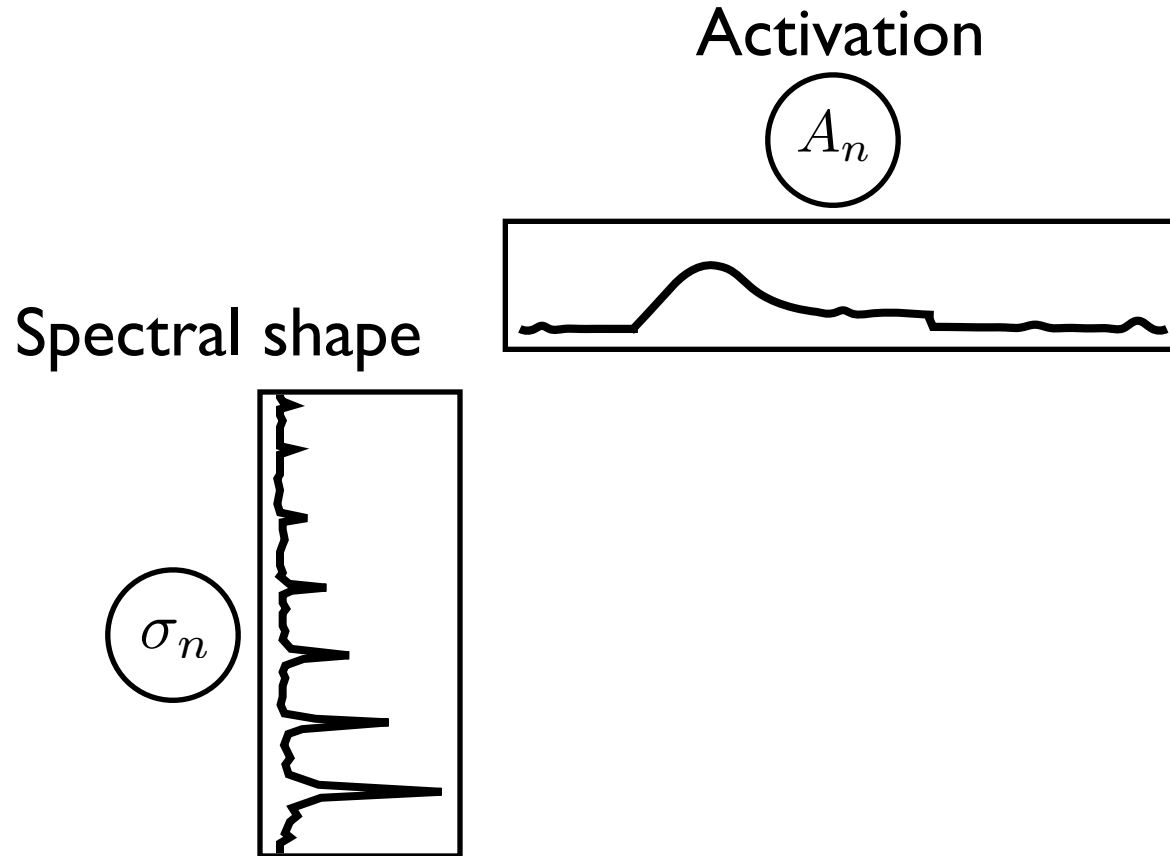

Component Spectrogram Model

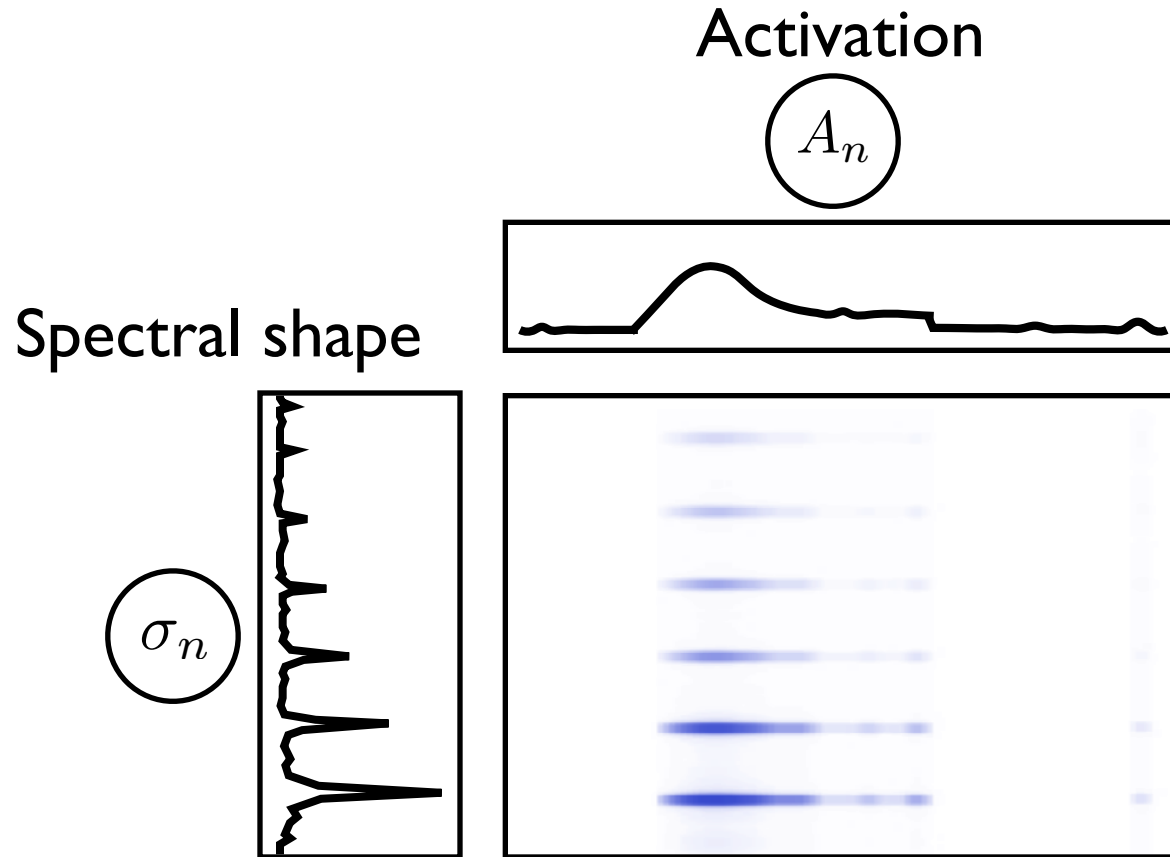

Component Spectrogram Model

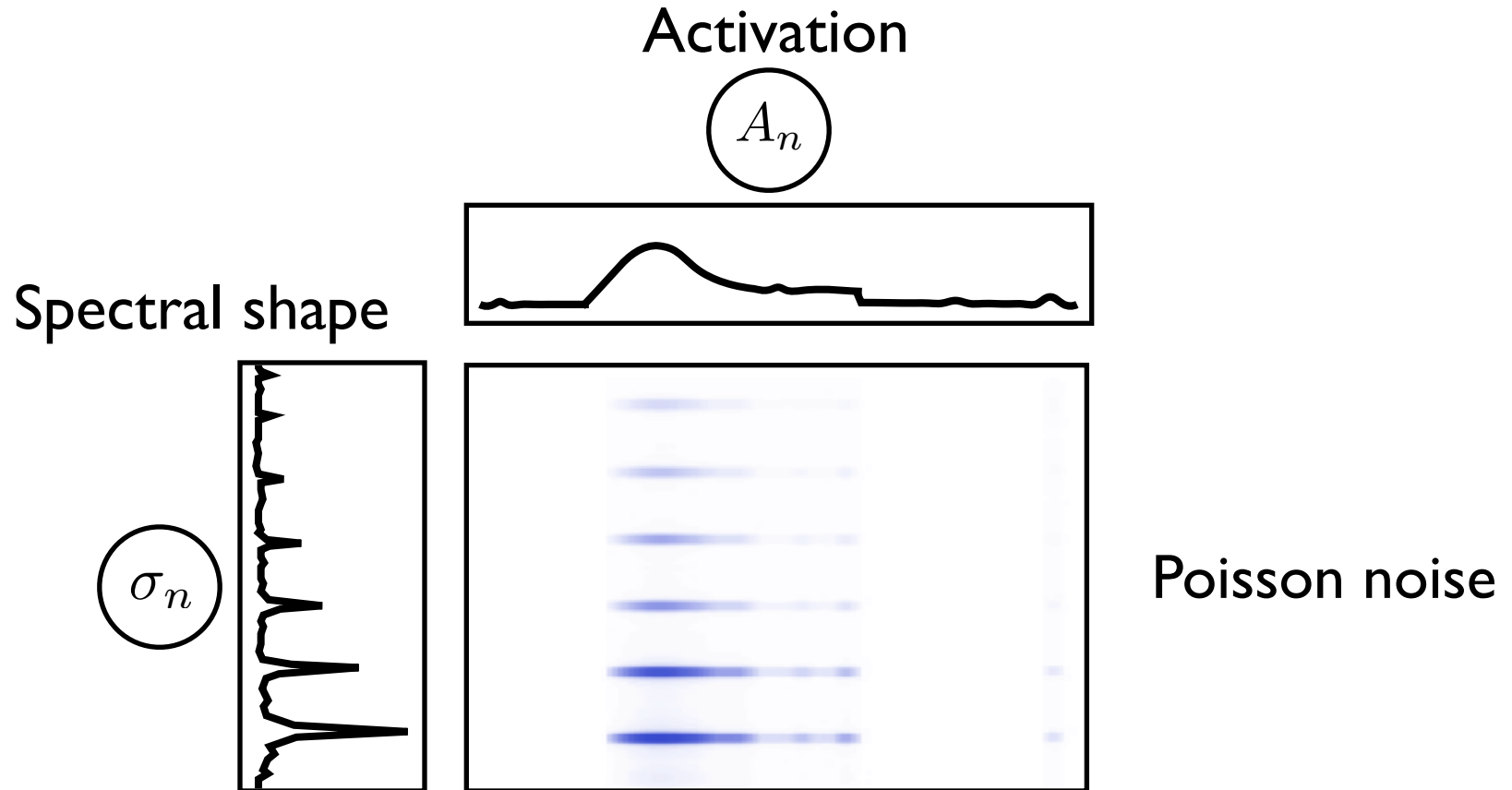

Component Spectrogram Model

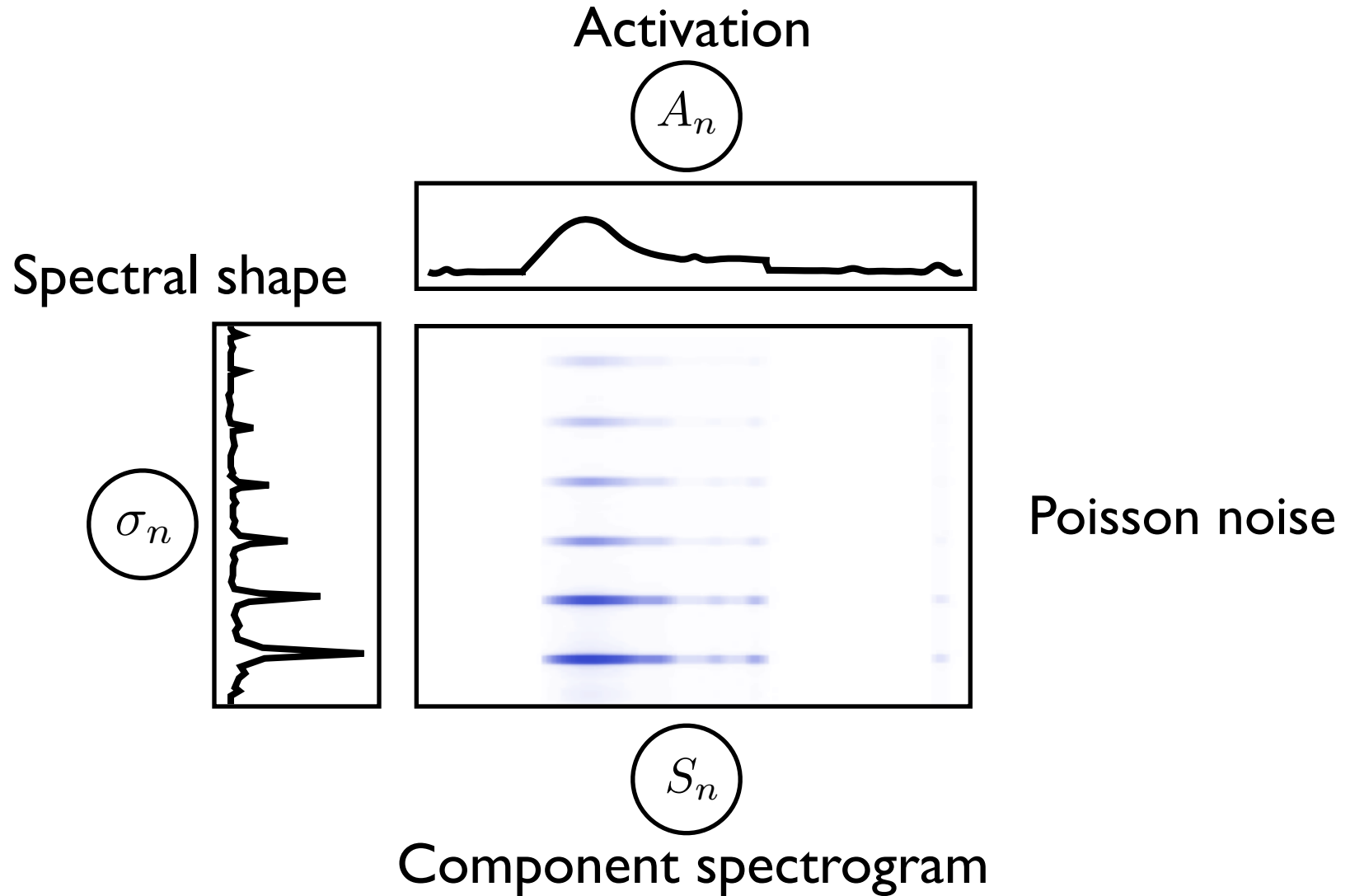

Total Spectrogram Model

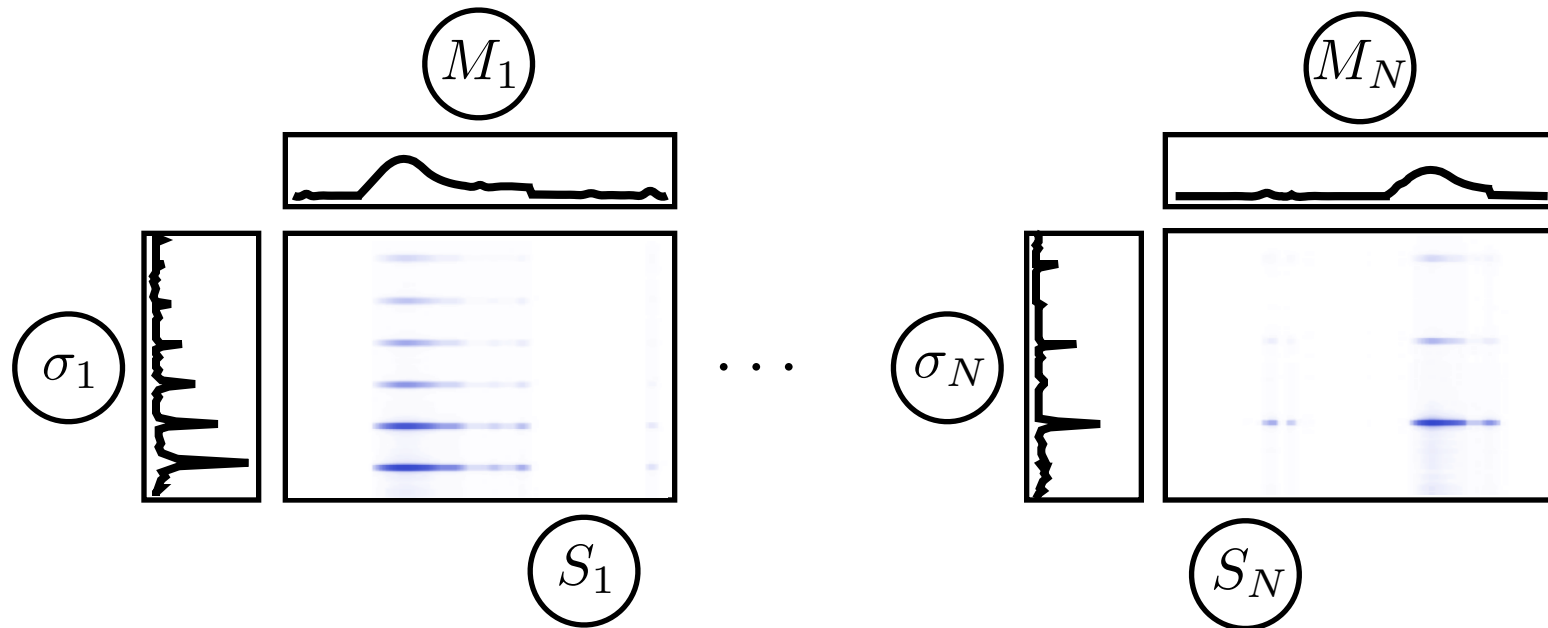

Total Spectrogram Model

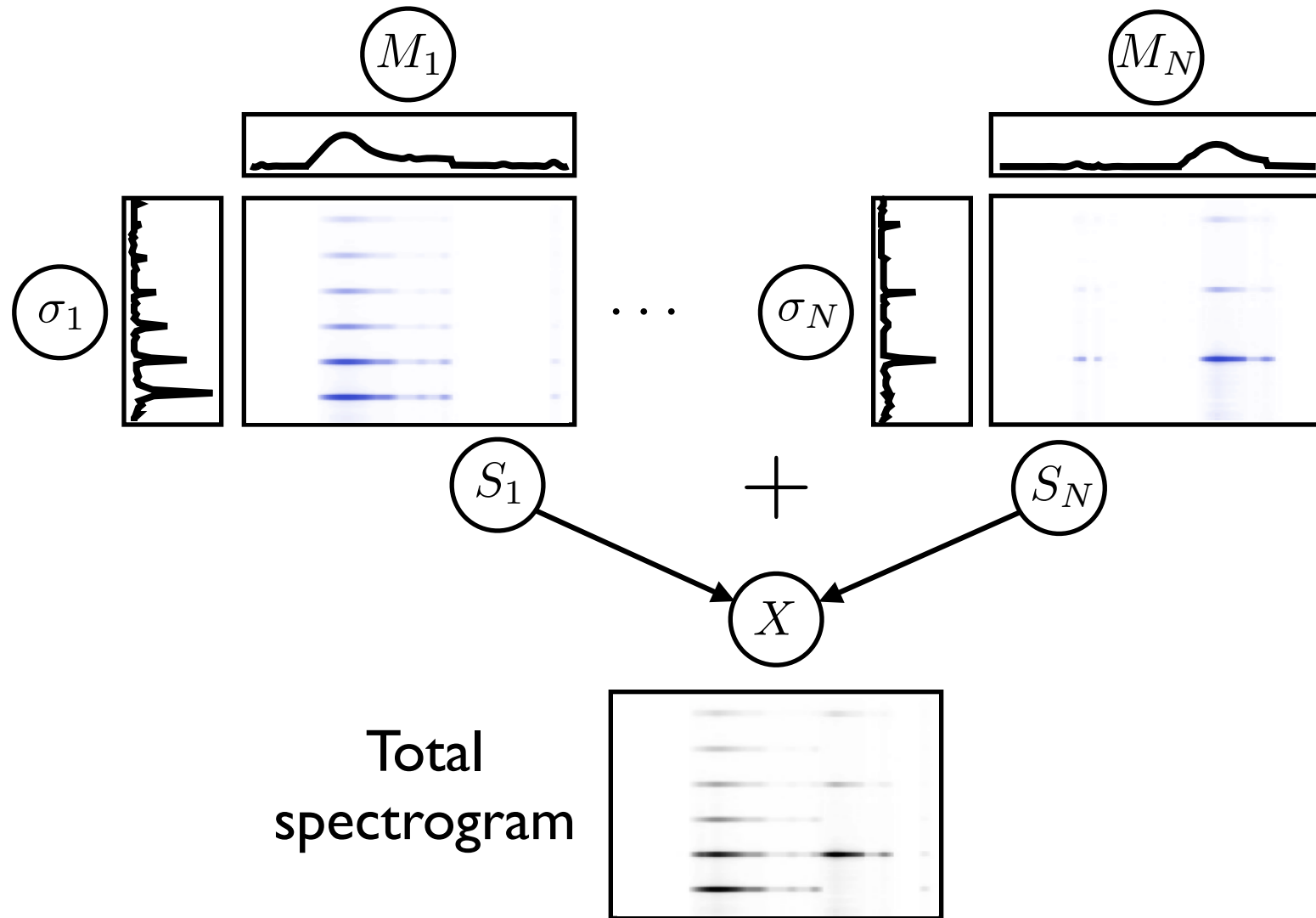

Learning and Inference

Parameters

Latent variables

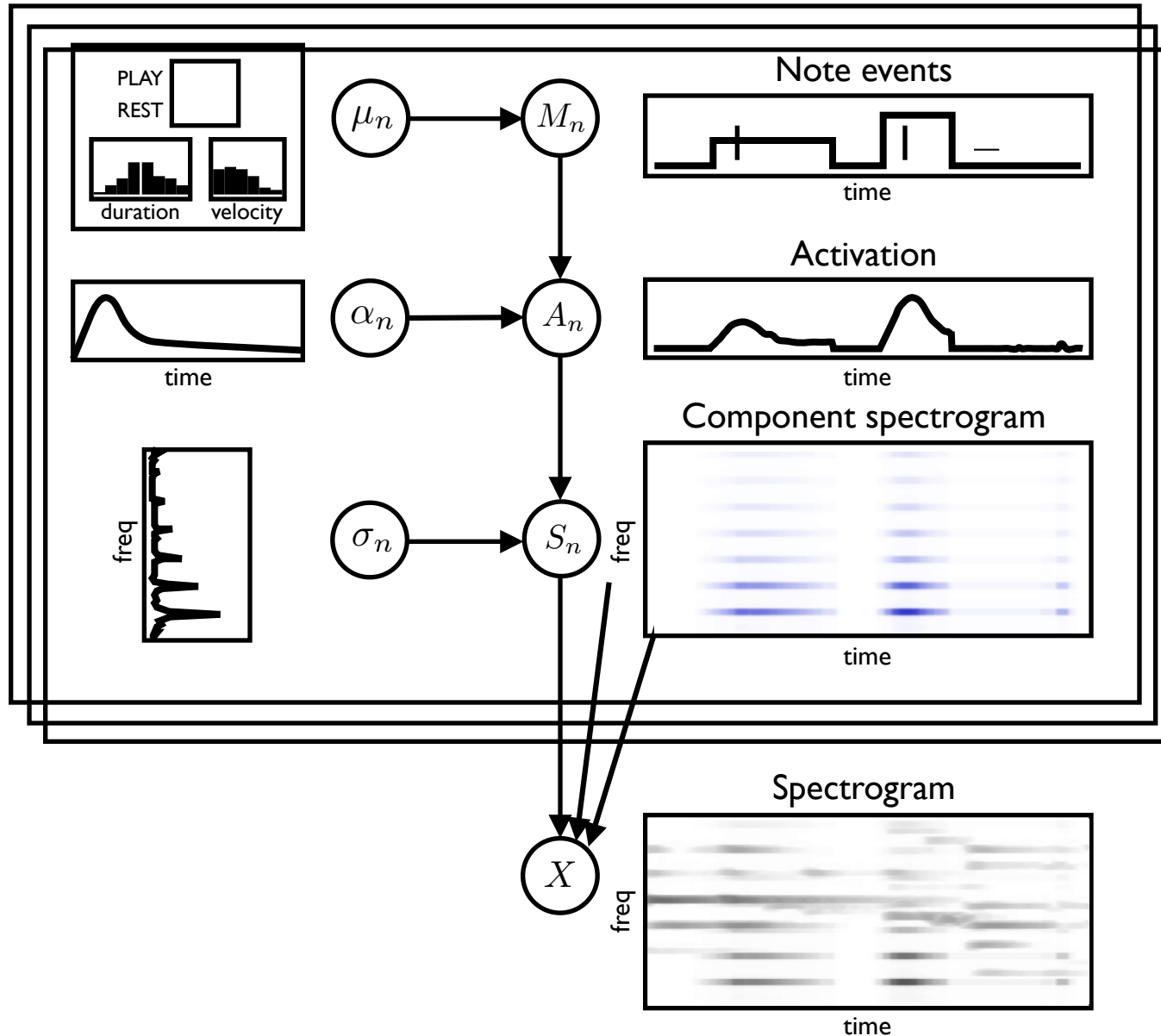

Learning and Inference

Parameters

Latent variables

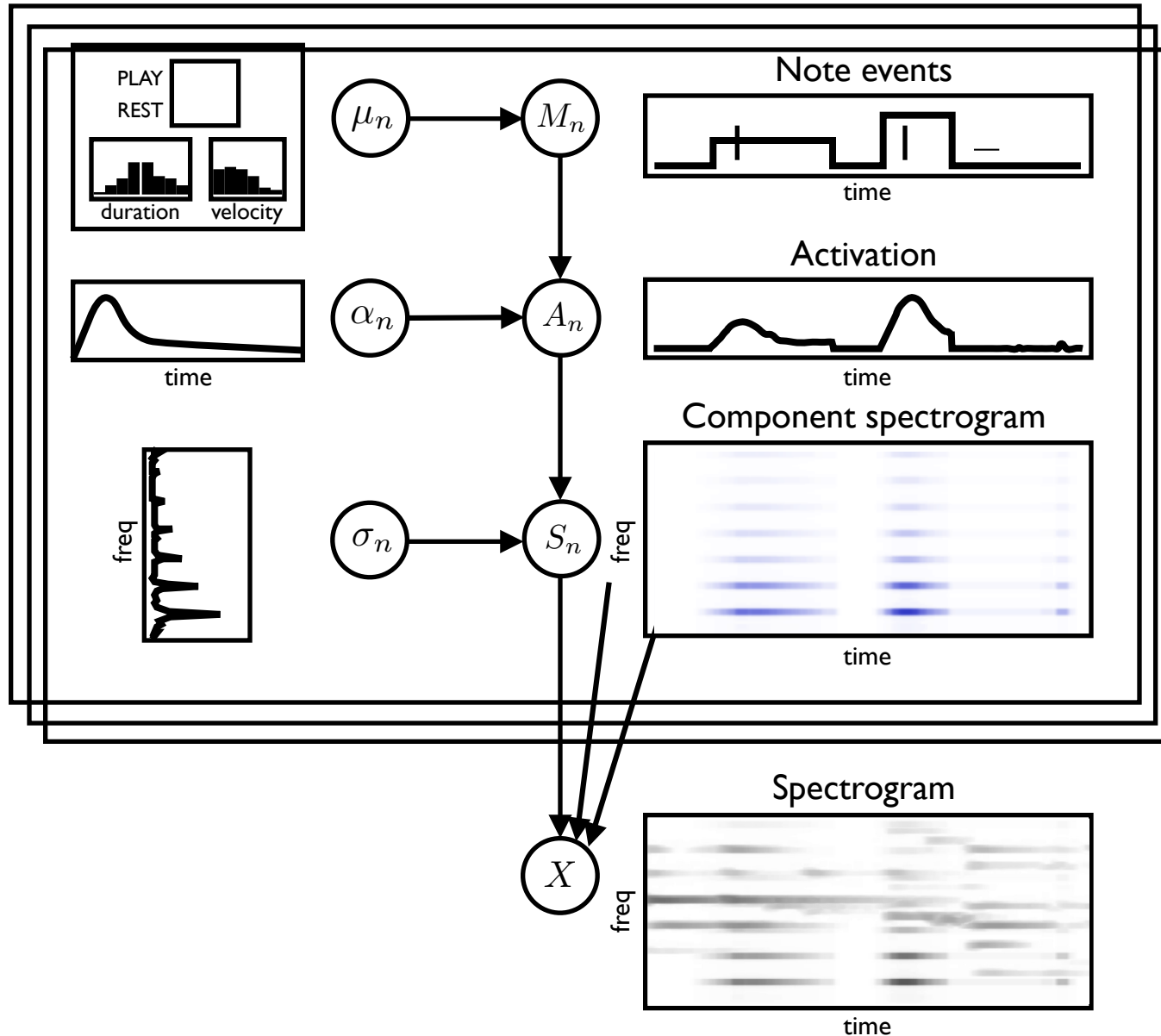

Learning and Inference

Parameters

Latent variables

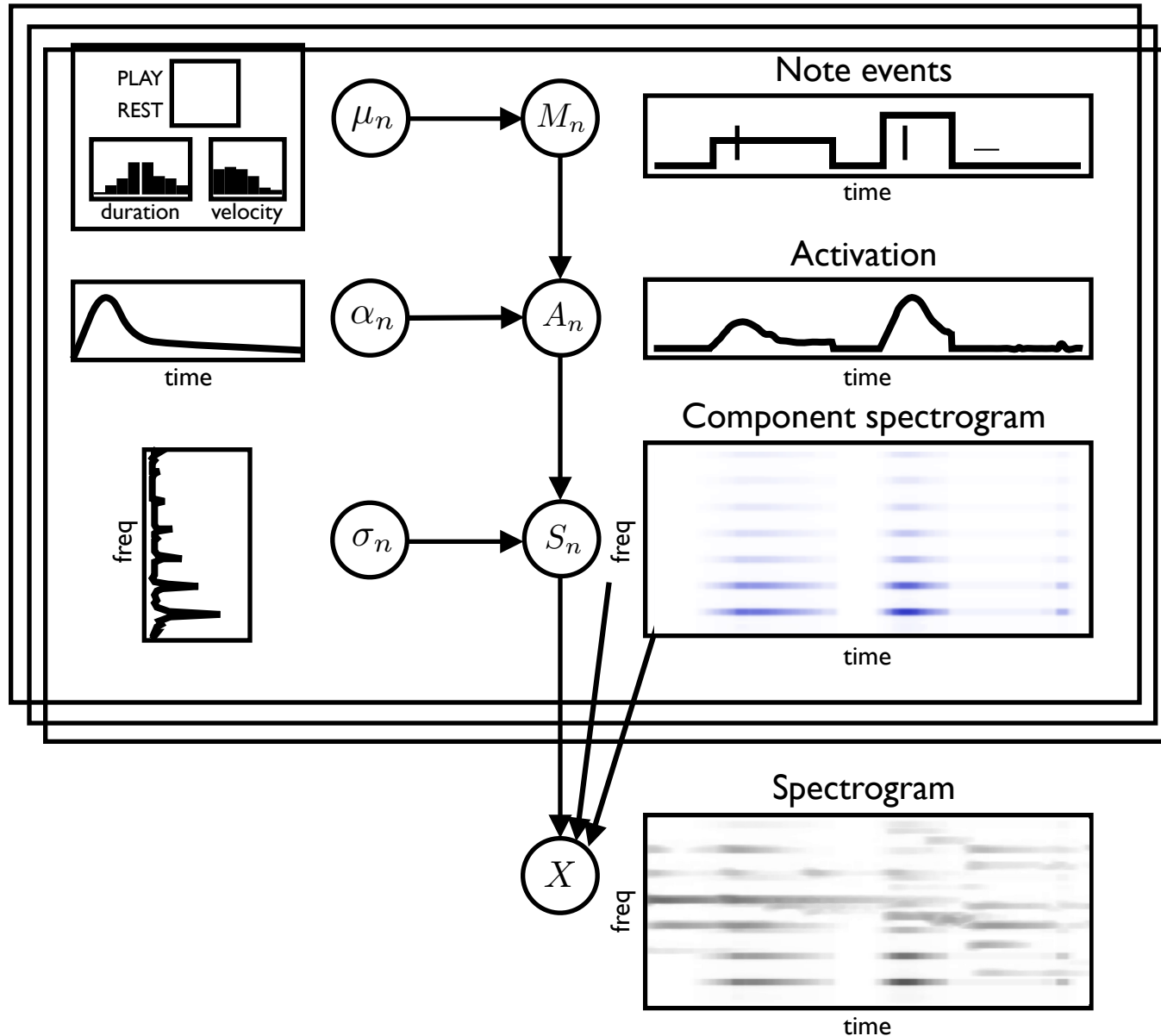

Learning and Inference

Parameters

Latent variables

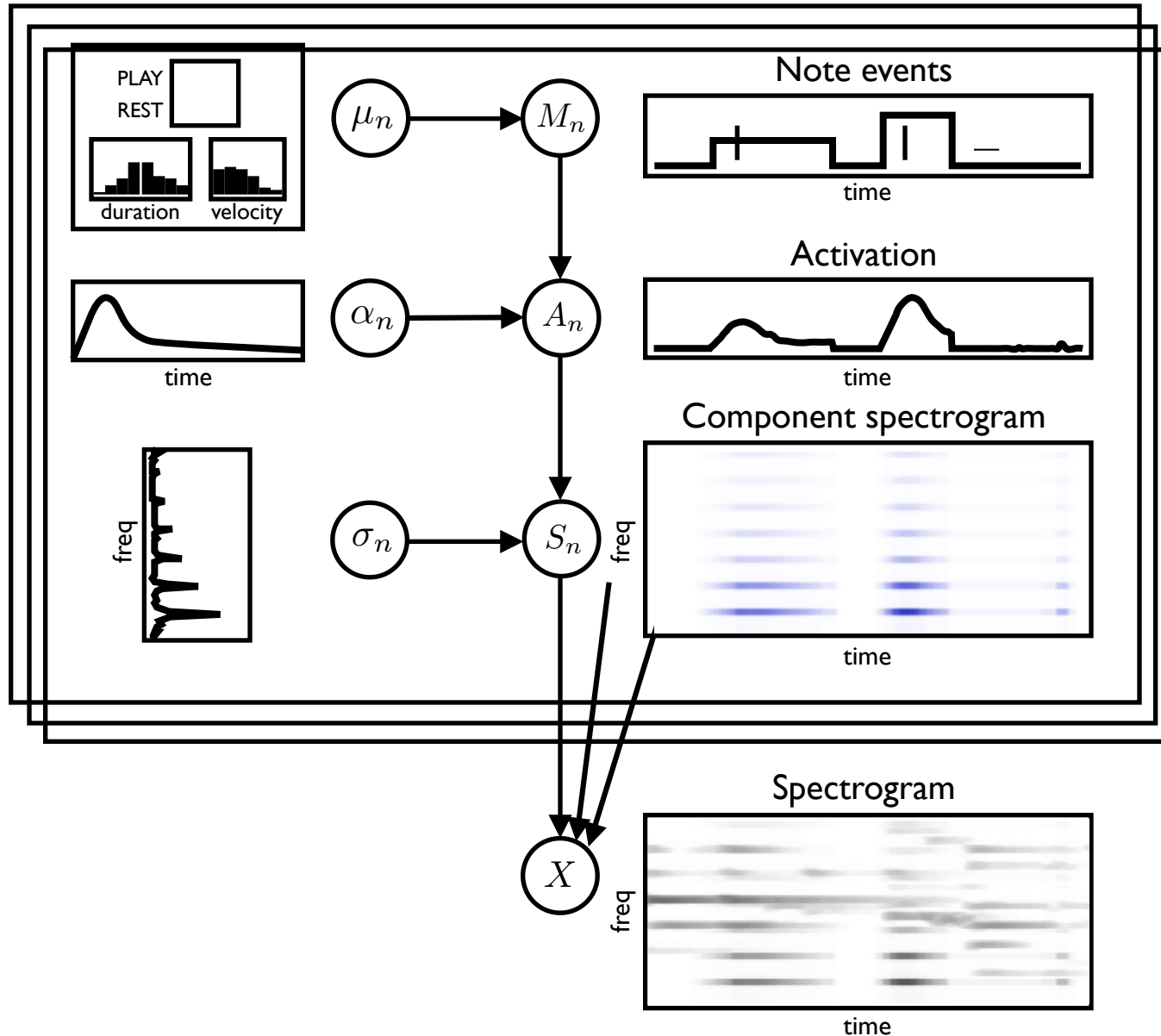

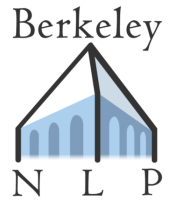

Learning and Inference

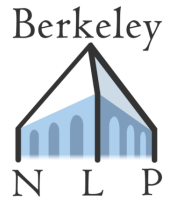

Learning and Inference

Note events update:



$$M | A, \alpha, \mu$$



Learning and Inference

Note events update:



$$M | A, \alpha, \mu$$

Semi-Markov dynamic program

Learning and Inference

Note events update:



$$M | A, \alpha, \mu$$

Semi-Markov dynamic program

Temporal shapes update:



Learning and Inference

Note events update:



$$M | A, \alpha, \mu$$

Semi-Markov dynamic program

Temporal shapes update:



Closed form update

Learning and Inference

Note events update:



$$M | A, \alpha, \mu$$

Semi-Markov dynamic program

Temporal shapes update:



$$\alpha | A, M$$

Closed form update

Activations update:



$$A | M, X, \alpha, \sigma$$

Learning and Inference

Note events update:



$$M | A, \alpha, \mu$$

Semi-Markov dynamic program

Temporal shapes update:



$$\alpha | A, M$$

Closed form update

Activations update:



$$A | M, X, \alpha, \sigma$$

Exponentiated gradient ascent

Learning and Inference

Note events update:



$$M | A, \alpha, \mu$$

Semi-Markov dynamic program

Temporal shapes update:



$$\alpha | A, M$$

Closed form update

Activations update:



$$A | M, X, \alpha, \sigma$$

Exponentiated gradient ascent

Spectral shapes update:

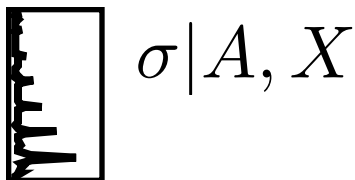

$$\sigma | A, X$$

Learning and Inference

Note events update:



$$M | A, \alpha, \mu$$

Semi-Markov dynamic program

Temporal shapes update:



$$\alpha | A, M$$

Closed form update

Activations update:



$$A | M, X, \alpha, \sigma$$

Exponentiated gradient ascent

Spectral shapes update:

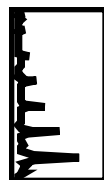

$$\sigma | A, X$$

Exponentiated gradient ascent

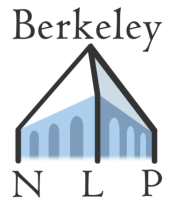

Evaluation

Onset F1

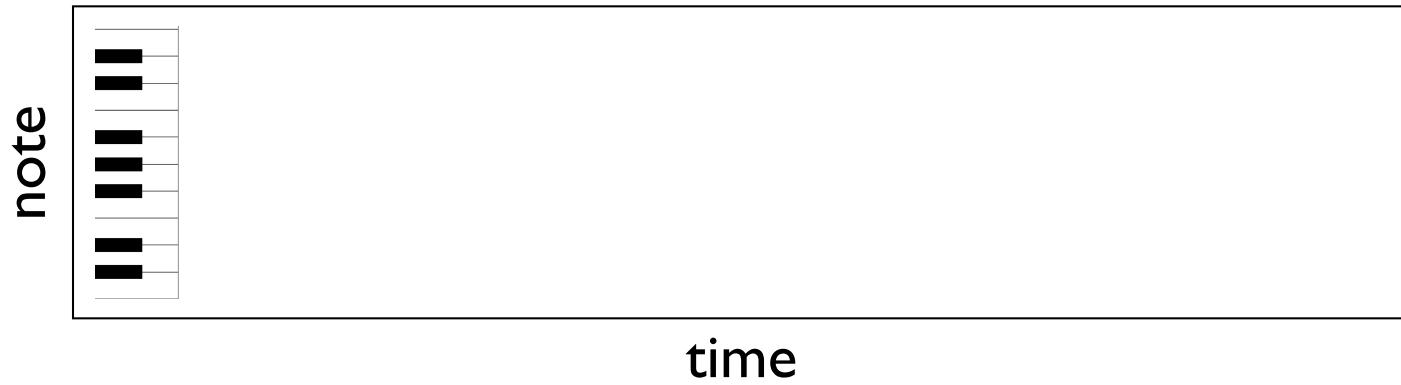

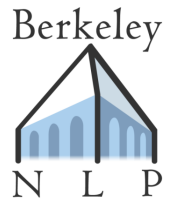

Evaluation

Onset F1

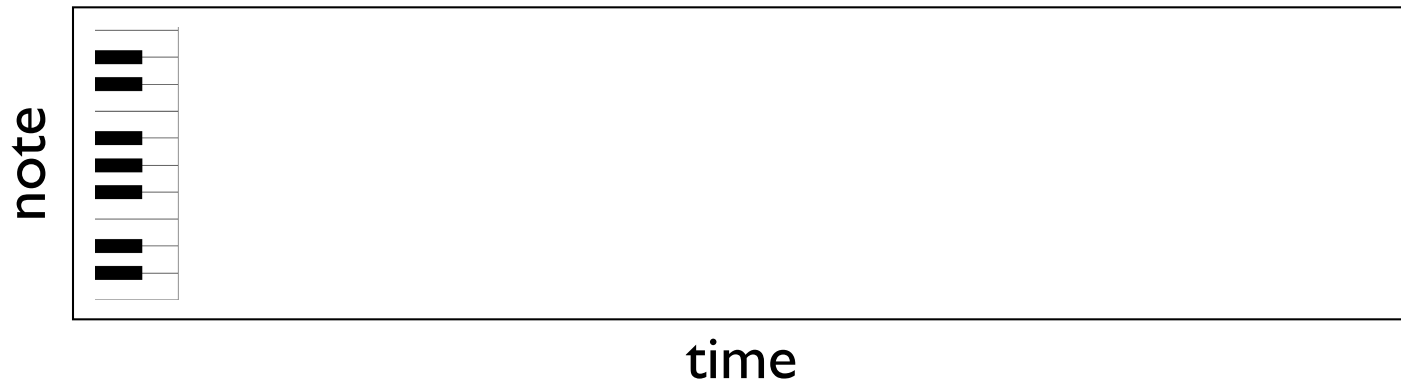

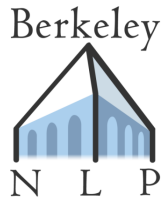

Results

MAPS Corpus

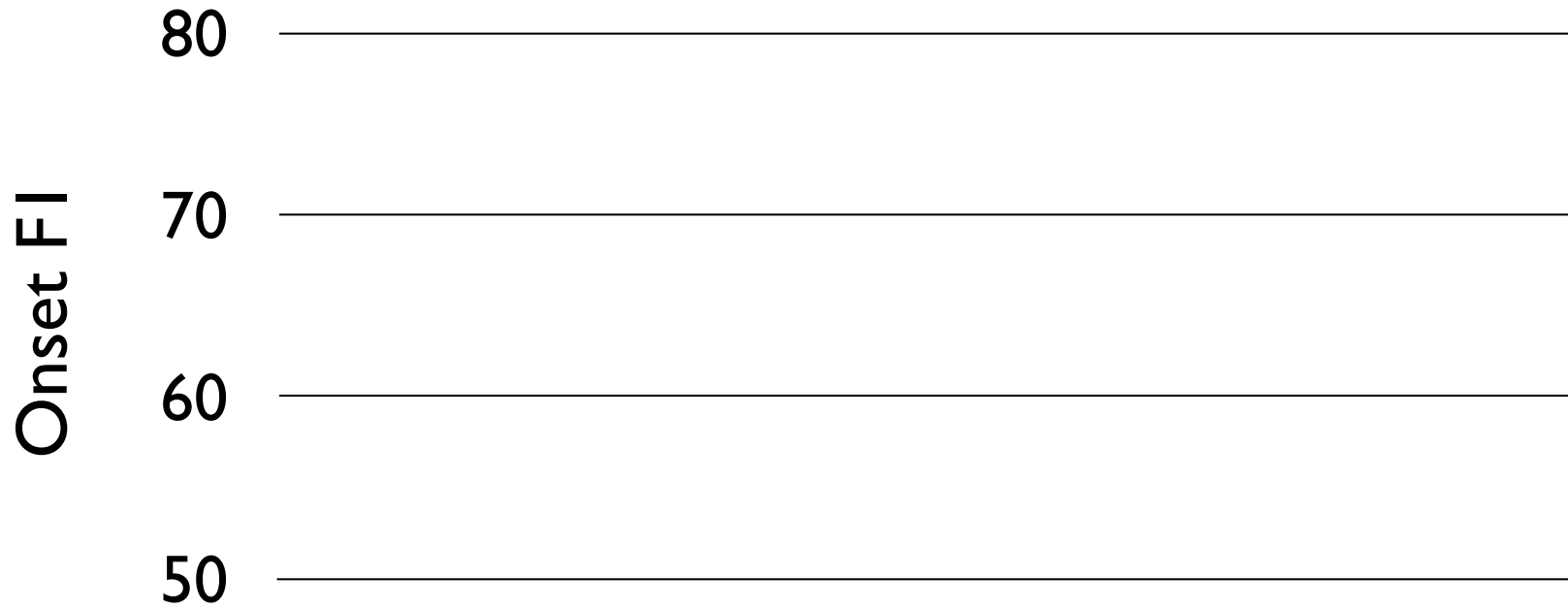

[Valentin et al. 2010]

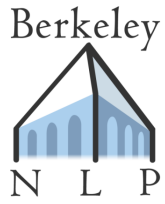

Results

MAPS Corpus

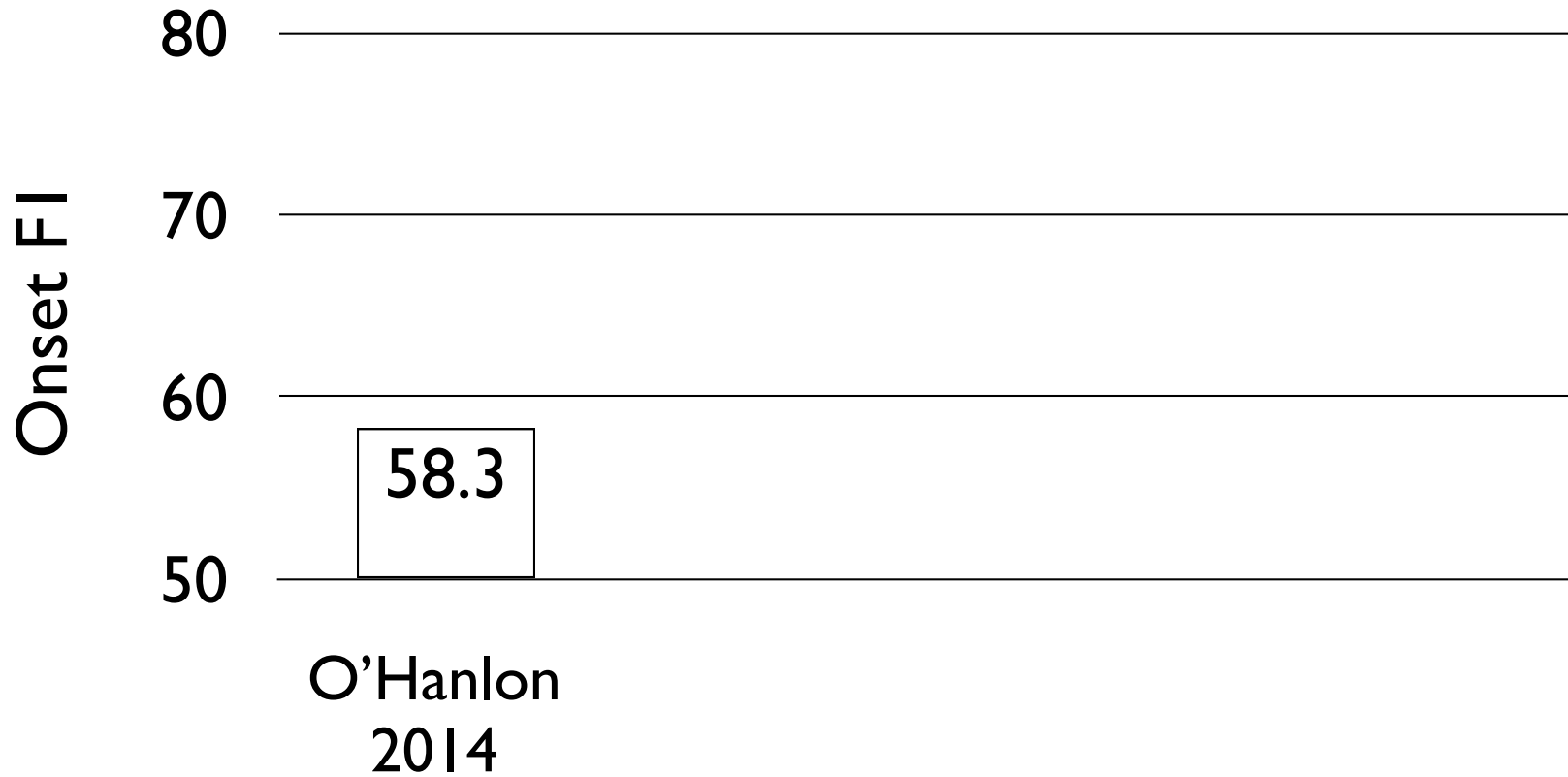

[Valentin et al. 2010]

Results

MAPS Corpus

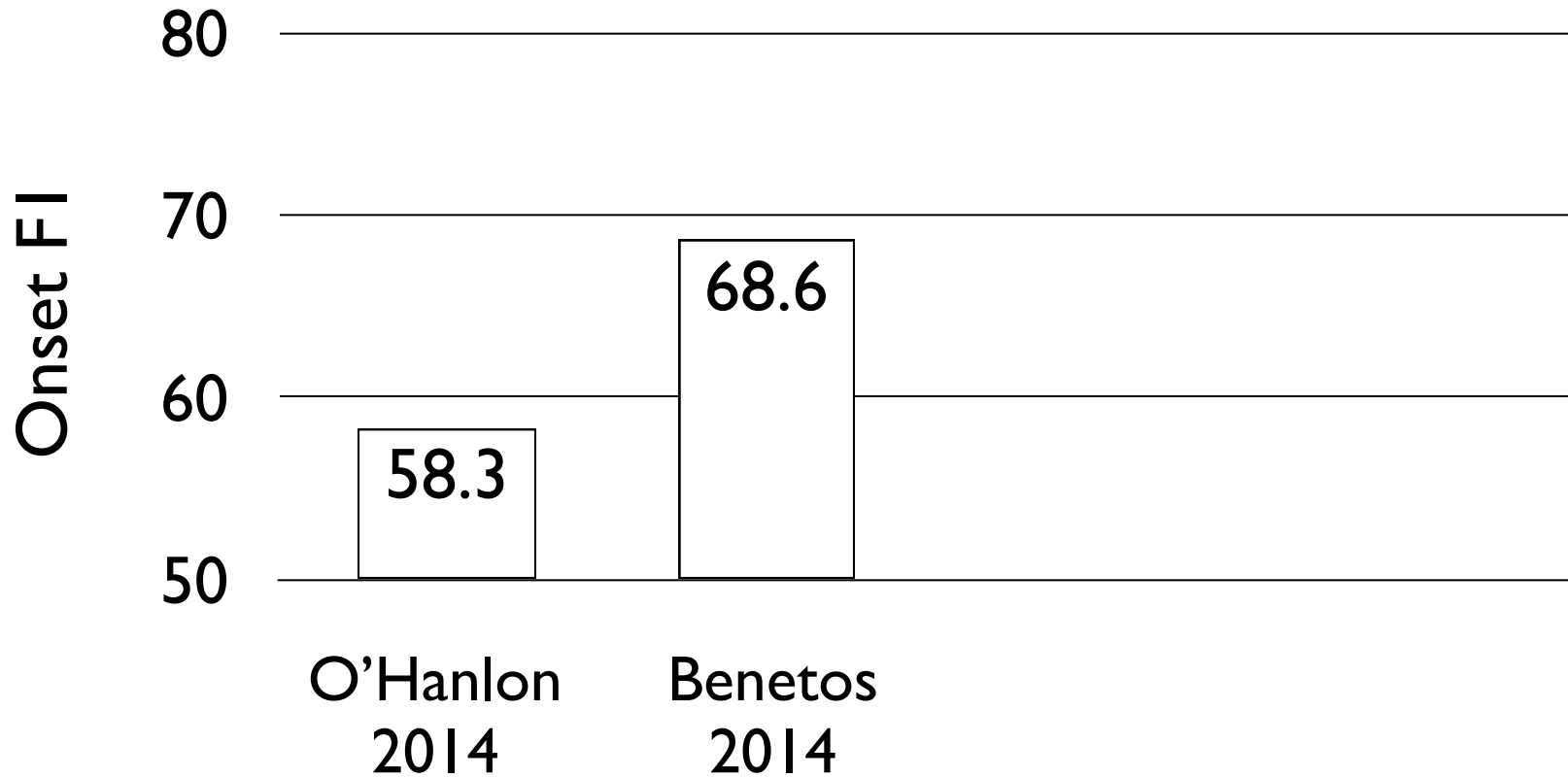

Results

MAPS Corpus

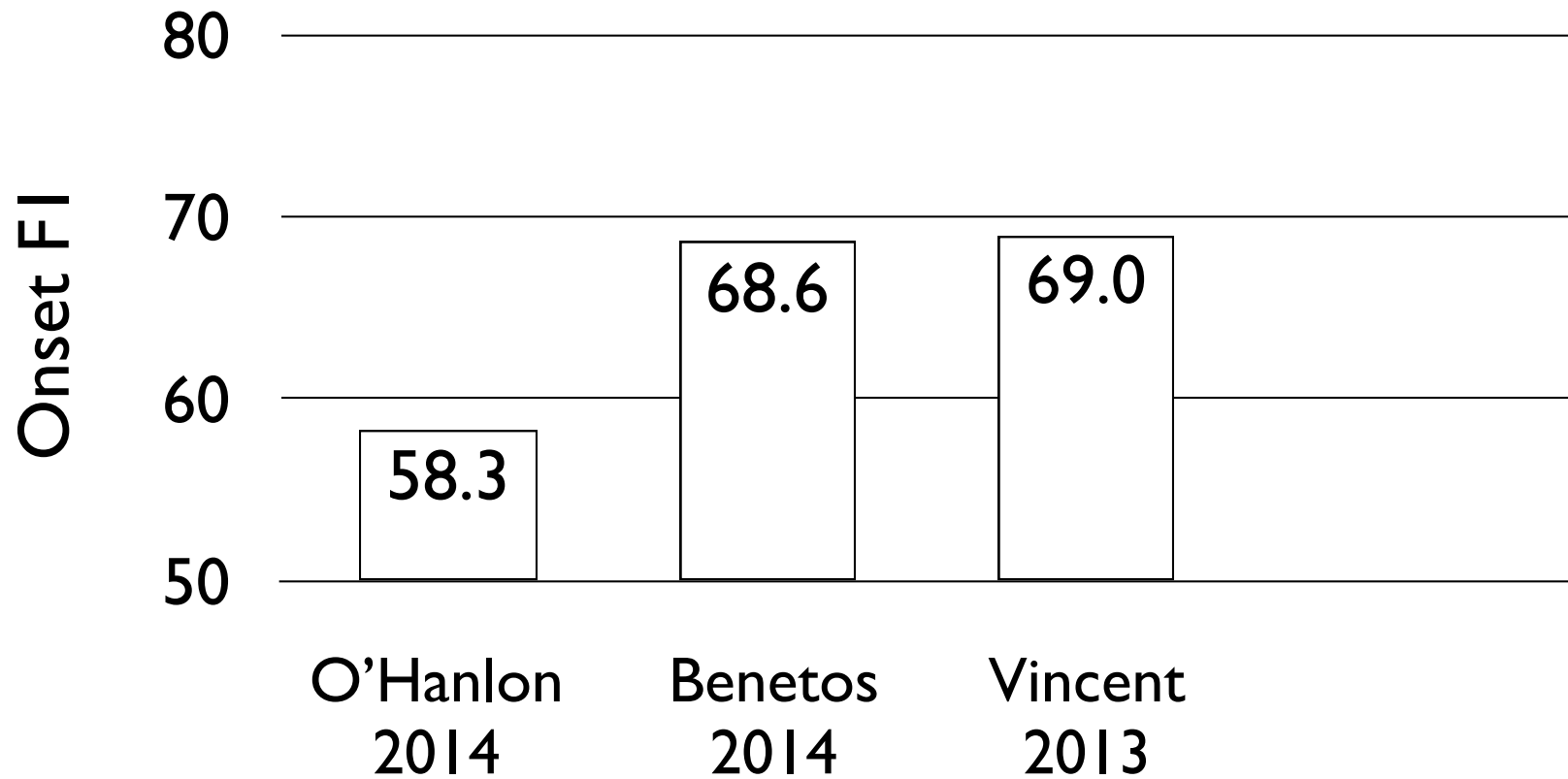

[Valentin et al. 2010]

Results

MAPS Corpus

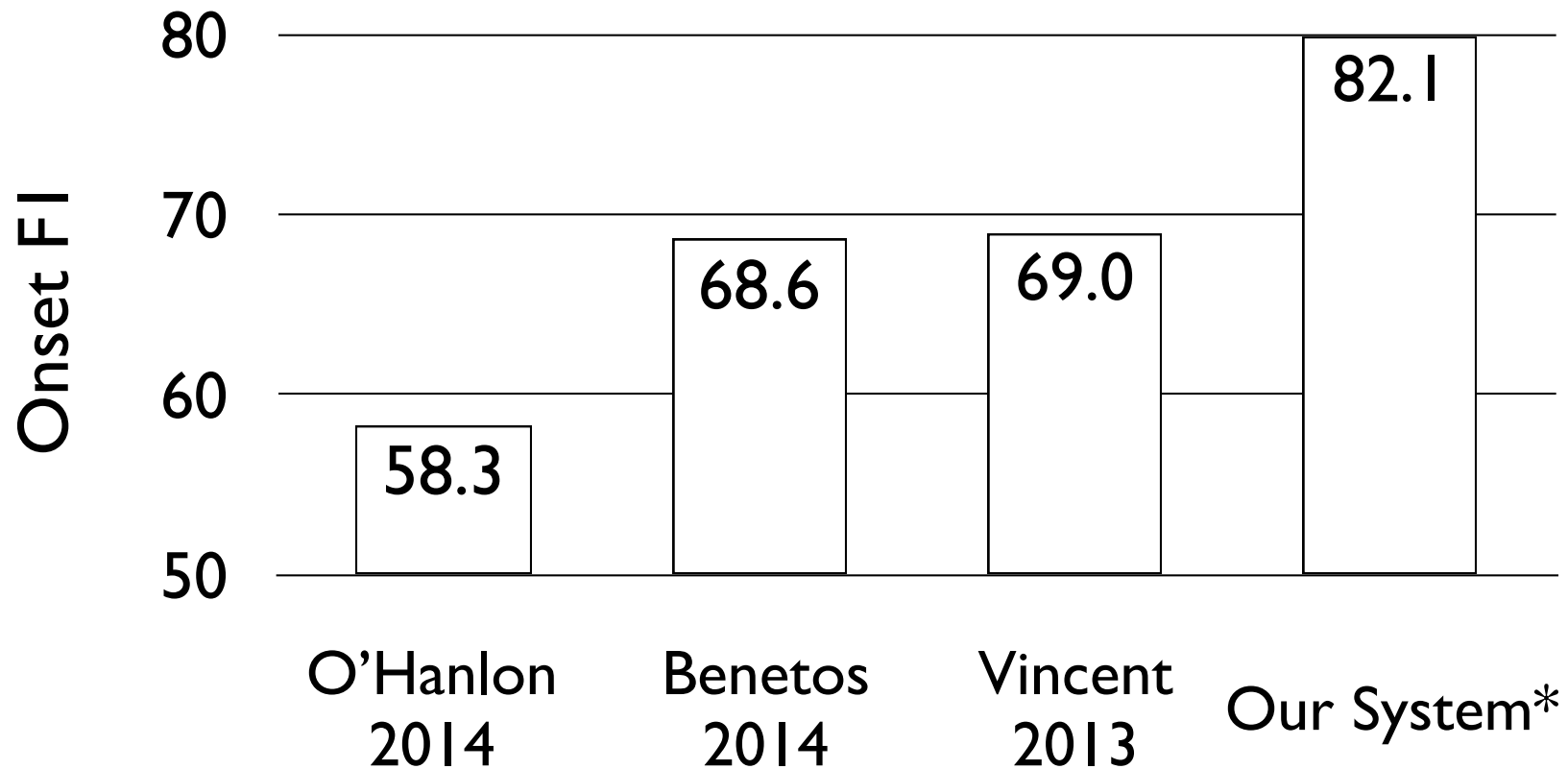

[Valentin et al. 2010]

[Berg-Kirkpatrick et al. 2014]

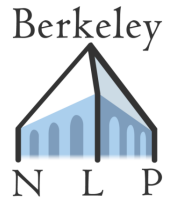

Transcription

Transcription

Reference



Transcription

Reference



Predicted



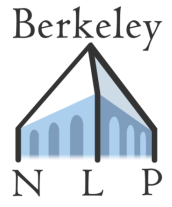

Resynthesized Examples

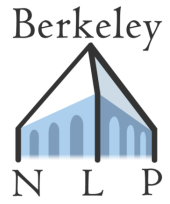

Resynthesized Examples

Grieg input



Resynthesized Examples

Grieg input

Grieg resynth piano

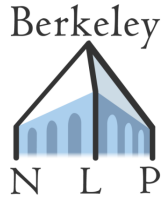

Resynthesized Examples

Grieg input

Grieg resynth piano

Grieg resynth guitar