

Natural Language Processing

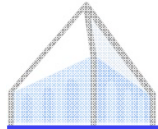

Acoustic Models

Dan Klein – UC Berkeley



The Noisy Channel Model

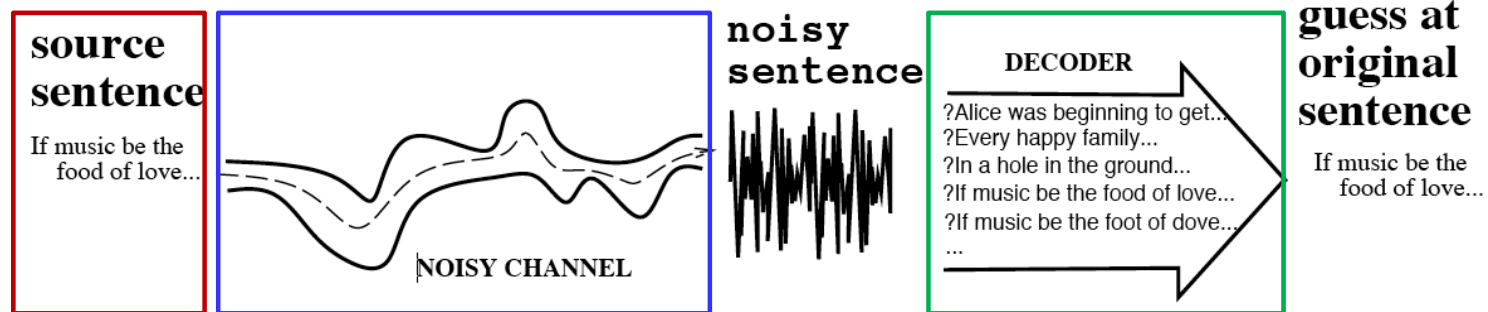

$$w^* = \arg \max_w P(w|a)$$
$$\propto \arg \max_w P(a|w)P(w)$$

Acoustic model: HMMs over word positions with mixtures of Gaussians as emissions

Language model: Distributions over sequences of words (sentences)

Figure: J & M

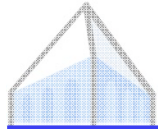

Speech Recognition Architecture

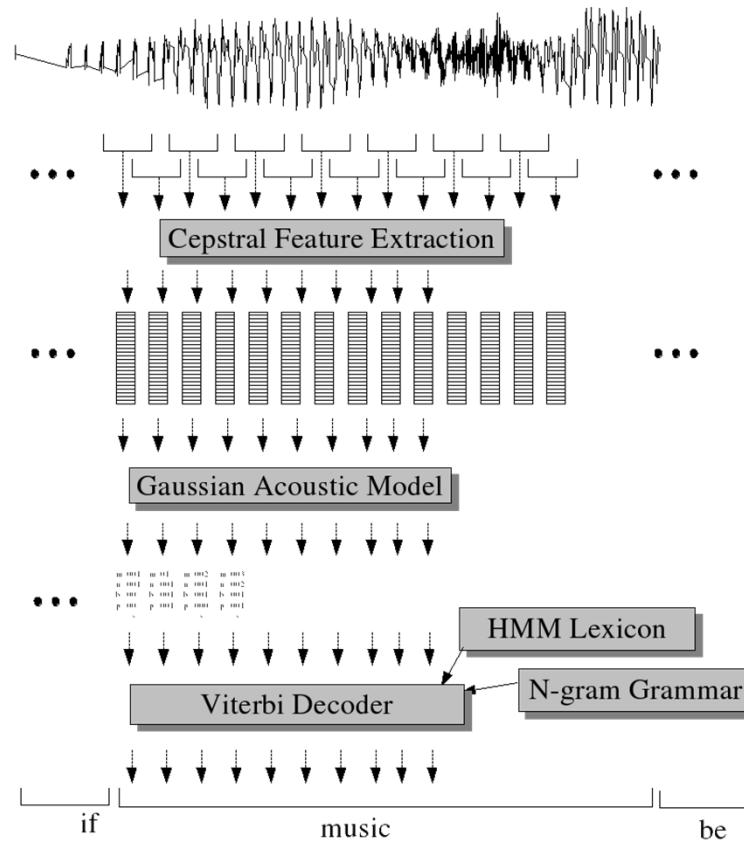
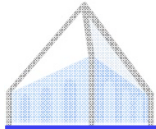

Figure: J & M

Feature Extraction



Digitizing Speech

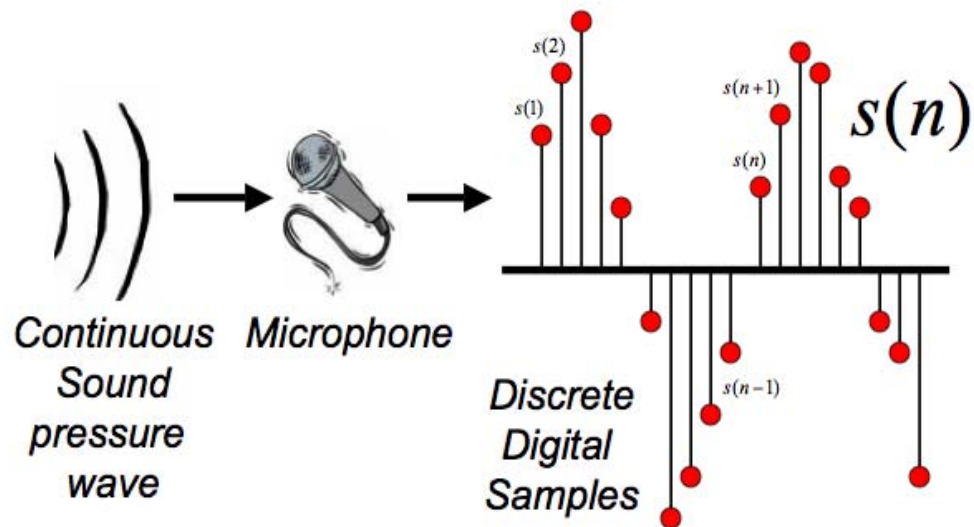
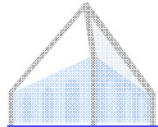

Figure: Bryan Pellom



Frame Extraction

- A frame (25 ms wide) extracted every 10 ms

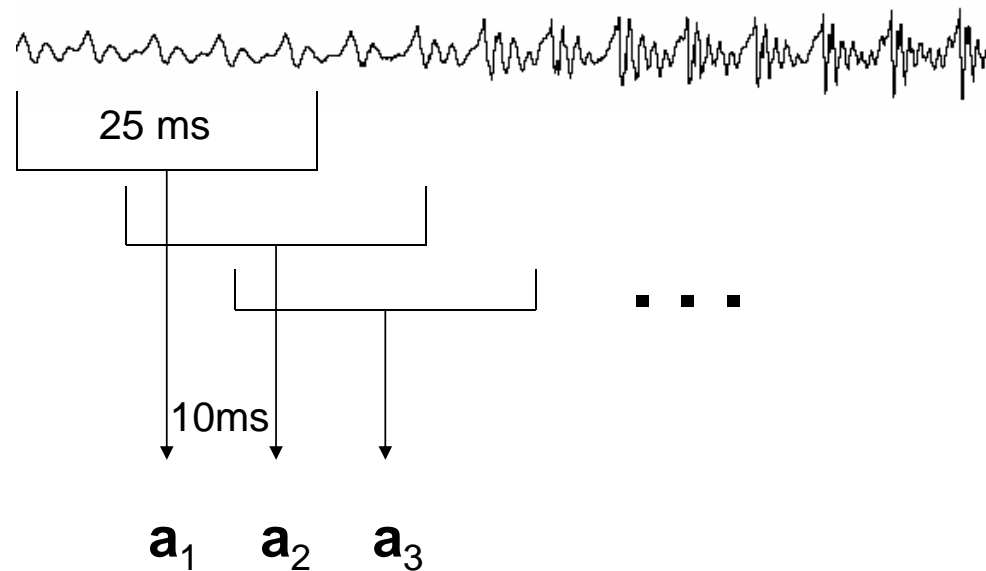
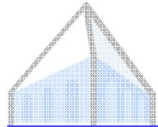
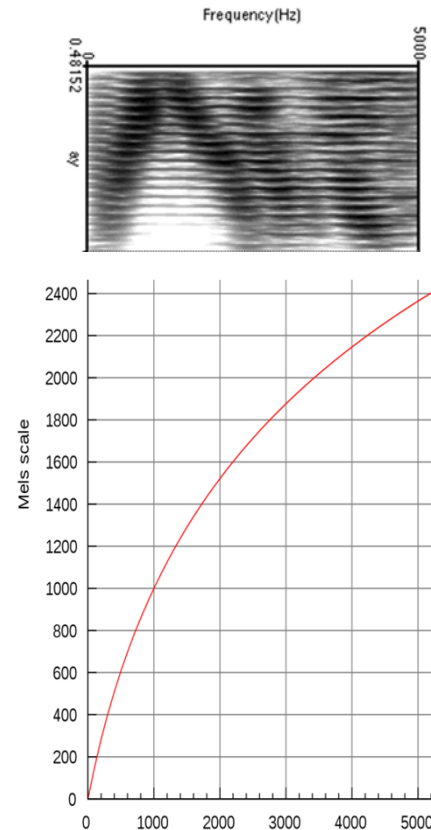

Figure: Simon Arnfield



Mel Freq. Cepstral Coefficients

- Do FFT to get spectral information
 - Like the spectrogram we saw earlier
- Apply Mel scaling
 - Models human ear; more sensitivity in lower freqs
 - Approx linear below 1kHz, log above, equal samples above and below 1kHz
- Plus discrete cosine transform



[Graph: Wikipedia]

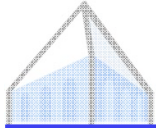

Final Feature Vector

- 39 (real) features per 10 ms frame:
 - 12 MFCC features
 - 12 delta MFCC features
 - 12 delta-delta MFCC features
 - 1 (log) frame energy
 - 1 delta (log) frame energy
 - 1 delta-delta (log frame energy)

- So each frame is represented by a 39D vector

Emission Model

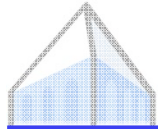

HMMs for Continuous Observations

- Before: discrete set of observations
- Now: feature vectors are real-valued
- Solution 1: discretization
- Solution 2: continuous emissions
 - Gaussians
 - Multivariate Gaussians
 - Mixtures of multivariate Gaussians
- A state is progressively
 - Context independent subphone (~3 per phone)
 - Context dependent phone (triphones)
 - State tying of CD phone

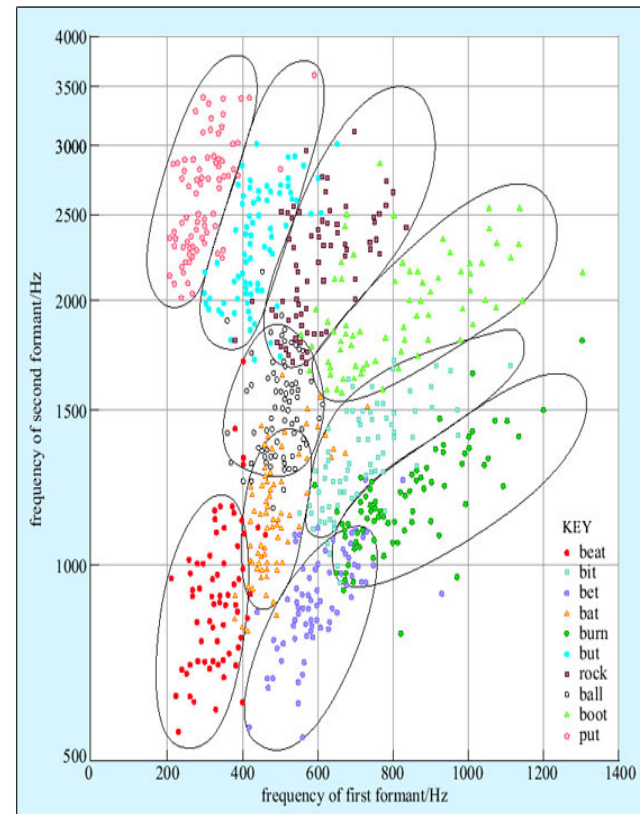

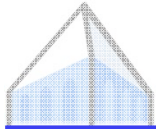

Vector Quantization

- Idea: discretization
 - Map MFCC vectors onto discrete symbols
 - Compute probabilities just by counting
- This is called vector quantization or VQ
- Not used for ASR any more
- But: useful to consider as a starting point

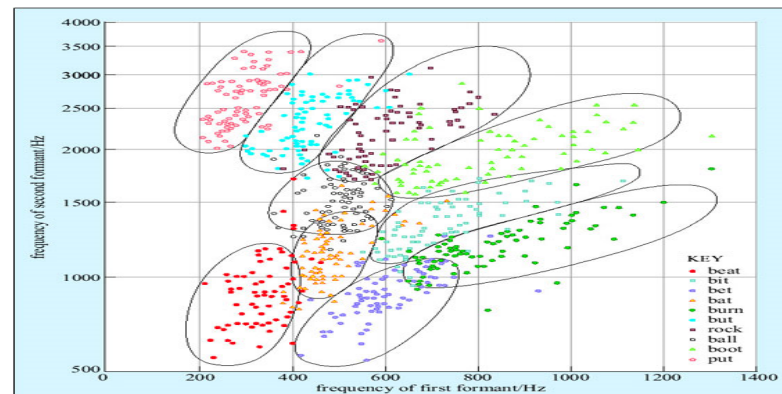
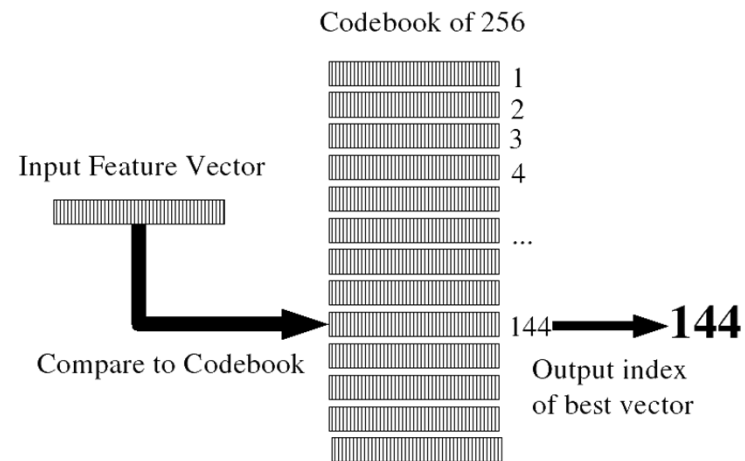

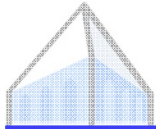

Gaussian Emissions

- VQ is insufficient for top-quality ASR
 - Hard to cover high-dimensional space with codebook
 - Moves ambiguity from the model to the preprocessing
- Instead: assume the possible values of the observation vectors are normally distributed.
 - Represent the observation likelihood function as a Gaussian?

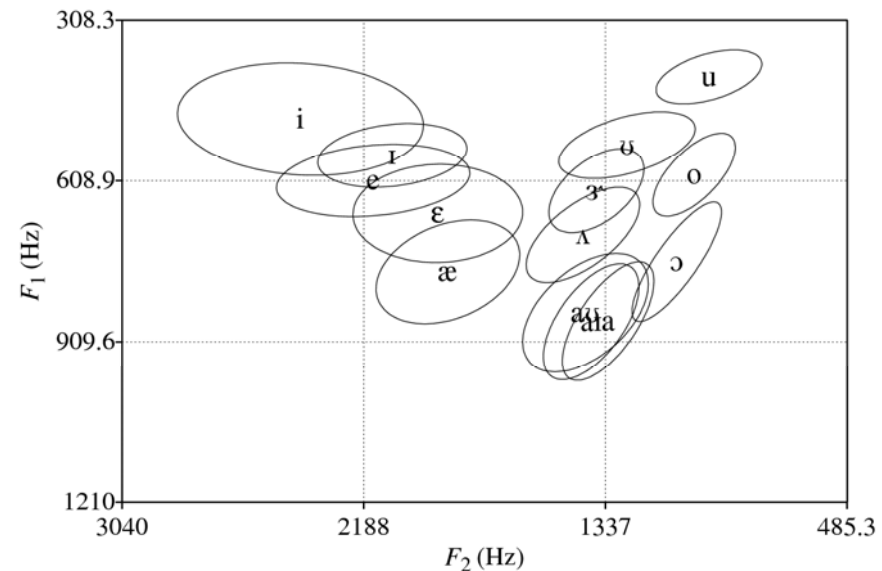

From bartus.org/akustyk

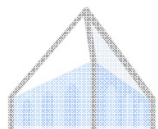

Gaussians for Acoustic Modeling

A Gaussian is parameterized by a mean and a variance:

$$P(x|\mu, \sigma) = \frac{1}{\sigma\sqrt{2\pi}} \exp\left(-\frac{(x-\mu)^2}{2\sigma^2}\right)$$

■ $P(x)$:

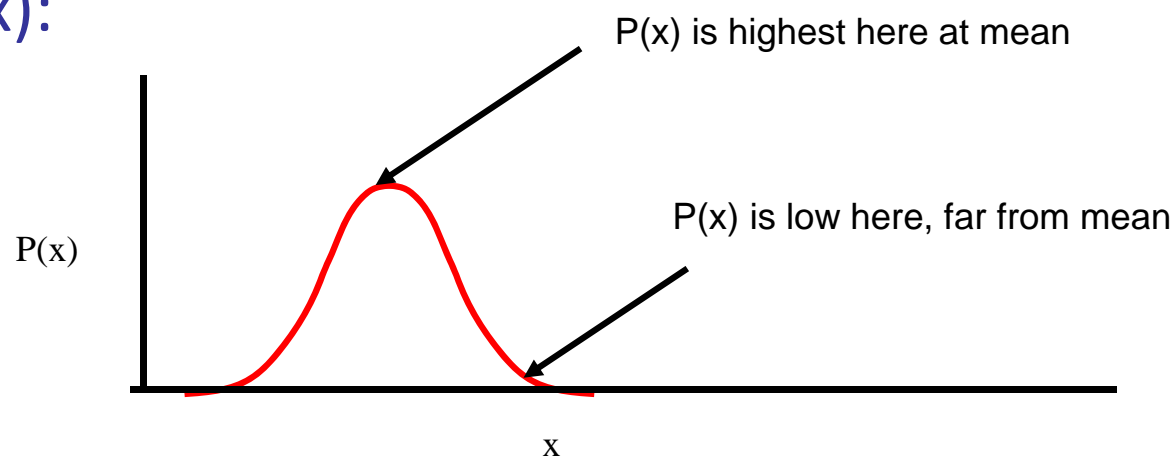

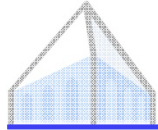

Multivariate Gaussians

- Instead of a single mean μ and variance σ^2 :

$$P(x|\mu, \sigma) = \frac{1}{\sigma\sqrt{2\pi}} \exp\left(-\frac{(x-\mu)^2}{2\sigma^2}\right)$$

- Vector of means μ and covariance matrix Σ

$$P(x|\mu, \Sigma) = \frac{1}{(2\pi)^{k/2}|\Sigma|^{1/2}} \exp\left(-\frac{1}{2}(x - \mu)^\top \Sigma^{-1}(x - \mu)\right)$$

- Usually assume diagonal covariance (!)
 - This isn't very true for FFT features, but is less bad for MFCC features

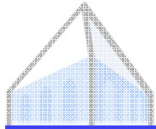

Gaussians: Size of Σ

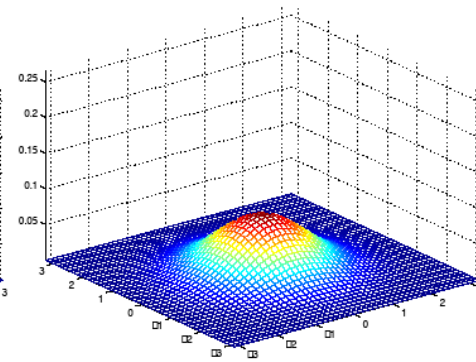
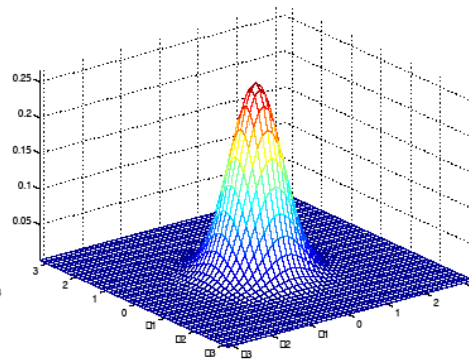
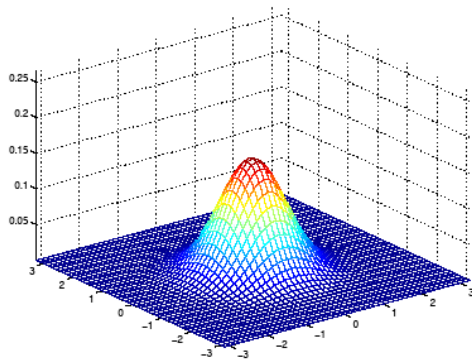

- $\mu = [0 \ 0]$
 - $\Sigma = I$
 - As Σ becomes larger, Gaussian becomes more spread out; as Σ becomes smaller, Gaussian more compressed
- | | | |
|-----------------|-----------------|-----------------|
| $\mu = [0 \ 0]$ | $\mu = [0 \ 0]$ | $\mu = [0 \ 0]$ |
| $\Sigma = I$ | $\Sigma = 0.6I$ | $\Sigma = 2I$ |

Text and figures from Andrew Ng

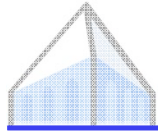

Gaussians: Shape of Σ

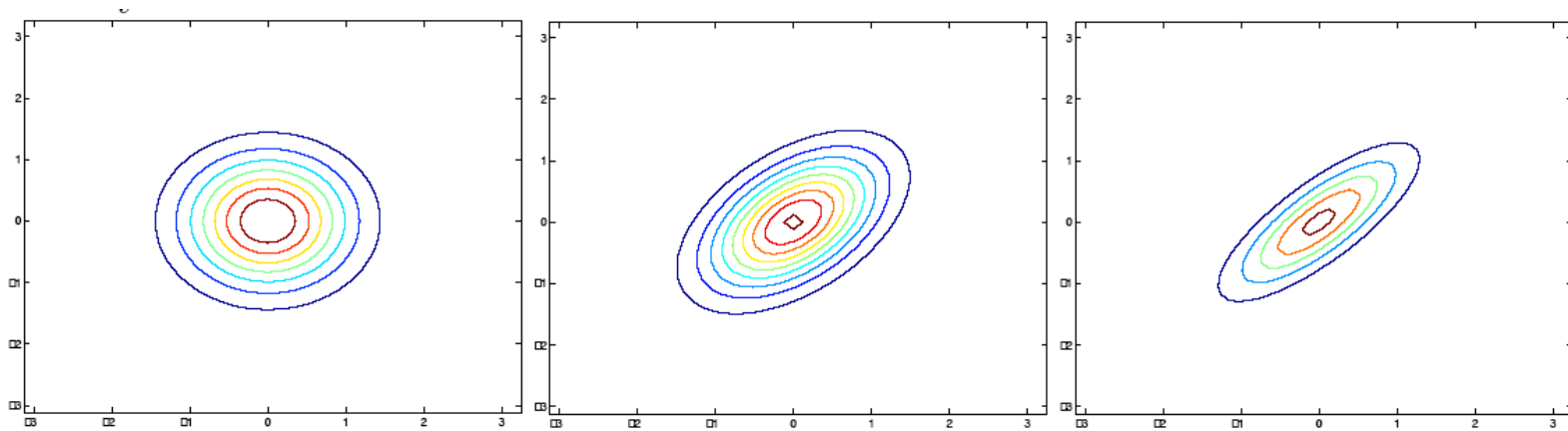

$$\Sigma = \begin{bmatrix} 1 & 0 \\ 0 & 1 \end{bmatrix}; \quad \Sigma = \begin{bmatrix} 1 & 0.5 \\ 0.5 & 1 \end{bmatrix}; \quad \Sigma = \begin{bmatrix} 1 & 0.8 \\ 0.8 & 1 \end{bmatrix}$$

- As we increase the off diagonal entries, more correlation between value of x and value of y

Text and figures from Andrew Ng

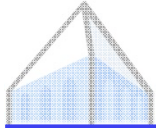

But we're not there yet

- Single Gaussians may do a bad job of modeling a complex distribution in any dimension
- Even worse for diagonal covariances
- Solution: mixtures of Gaussians

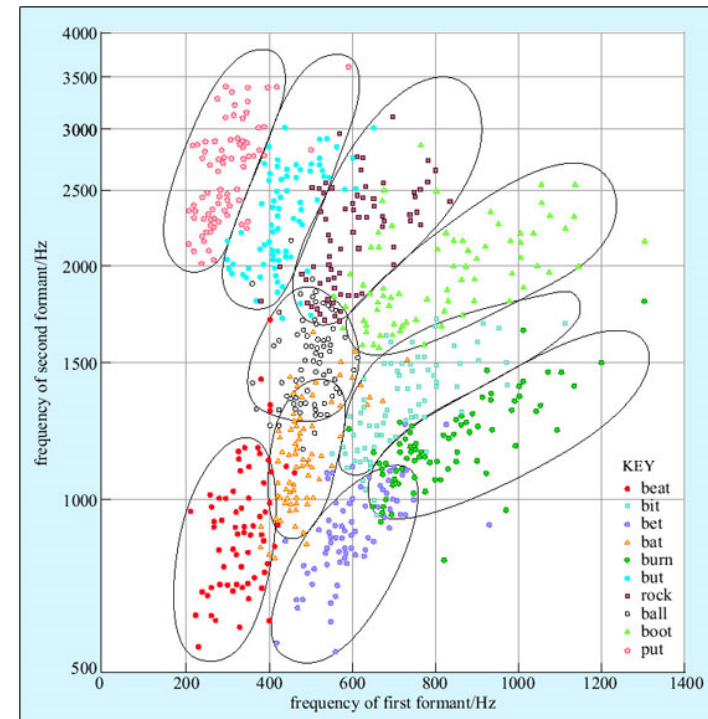

From openlearn.open.ac.uk

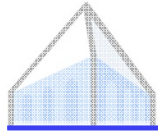

Mixtures of Gaussians

- Mixtures of Gaussians:

$$P(x|\mu_i, \Sigma_i) = \frac{1}{(2\pi)^{k/2} |\Sigma_i|^{1/2}} \exp\left(-\frac{1}{2}(x - \mu_i)^\top \Sigma_i^{-1}(x - \mu_i)\right)$$

$$P(x|\mu, \Sigma, \mathbf{c}) = \sum_i c_i P(x|\mu_i, \Sigma_i)$$

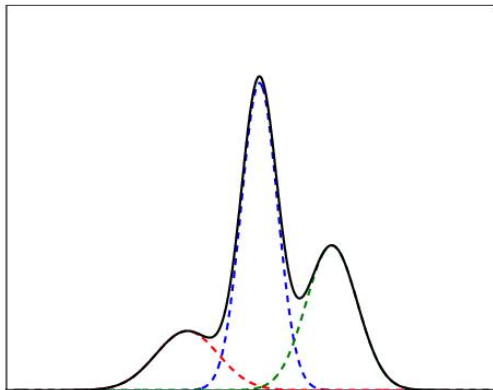

From robots.ox.ac.uk

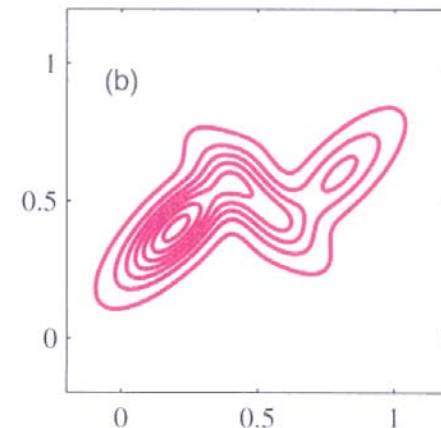
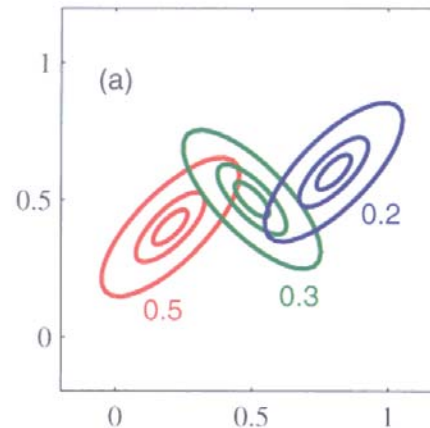

<http://www.itee.uq.edu.au/~comp4702>

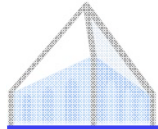

GMMs

- Summary: each state has an emission distribution $P(x|s)$ (likelihood function) parameterized by:
 - M mixture weights
 - M mean vectors of dimensionality D
 - Either M covariance matrices of $D \times D$ or M $D \times 1$ diagonal variance vectors
- Like soft vector quantization after all
 - Think of the mixture means as being learned codebook entries
 - Think of the Gaussian densities as a learned codebook distance function
 - Think of the mixture of Gaussians like a multinomial over codes
 - (Even more true given shared Gaussian inventories, cf next week)

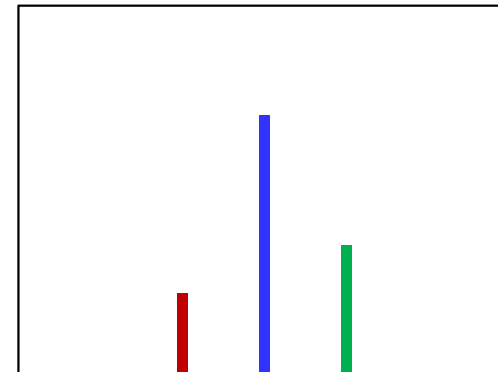
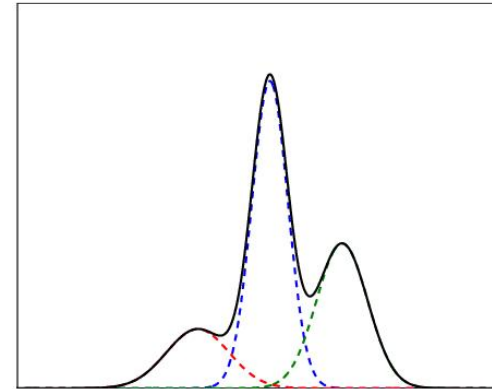

State Model

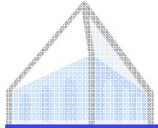

State Transition Diagrams

- Bayes Net: HMM as a Graphical Model

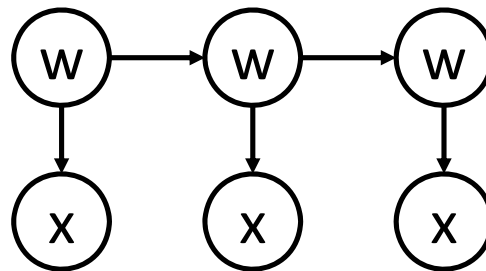

- State Transition Diagram: Markov Model as a Weighted FSA

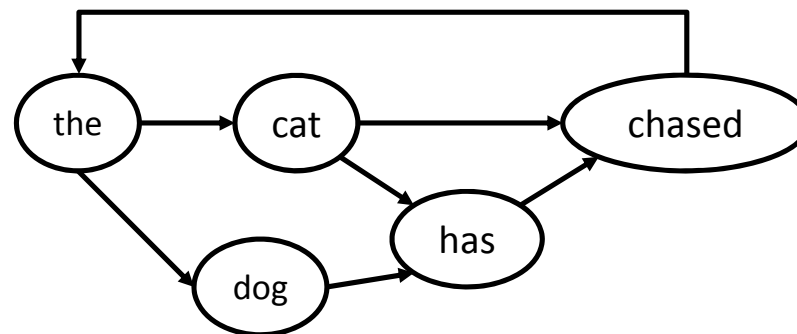

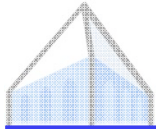

ASR Lexicon

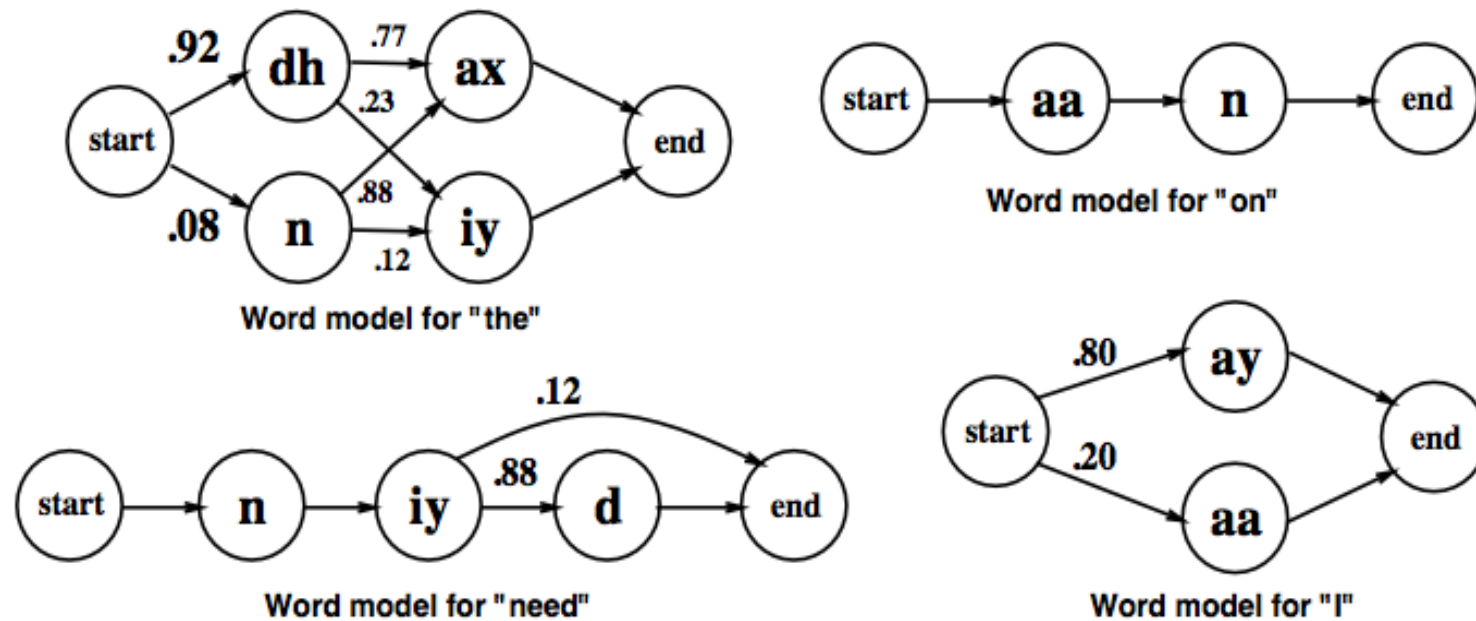
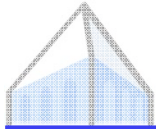

Figure: J & M



Lexical State Structure

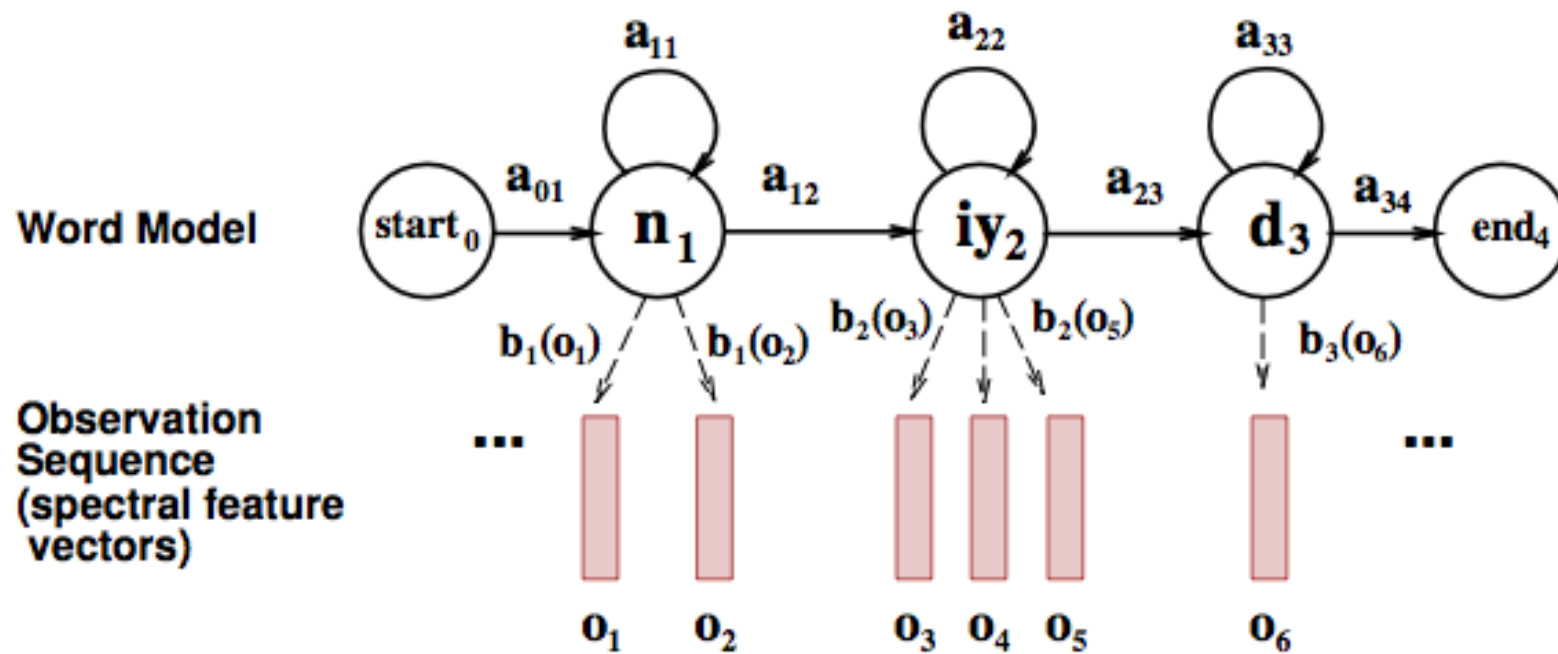
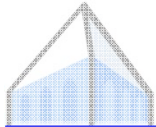

Figure: J & M



Adding an LM

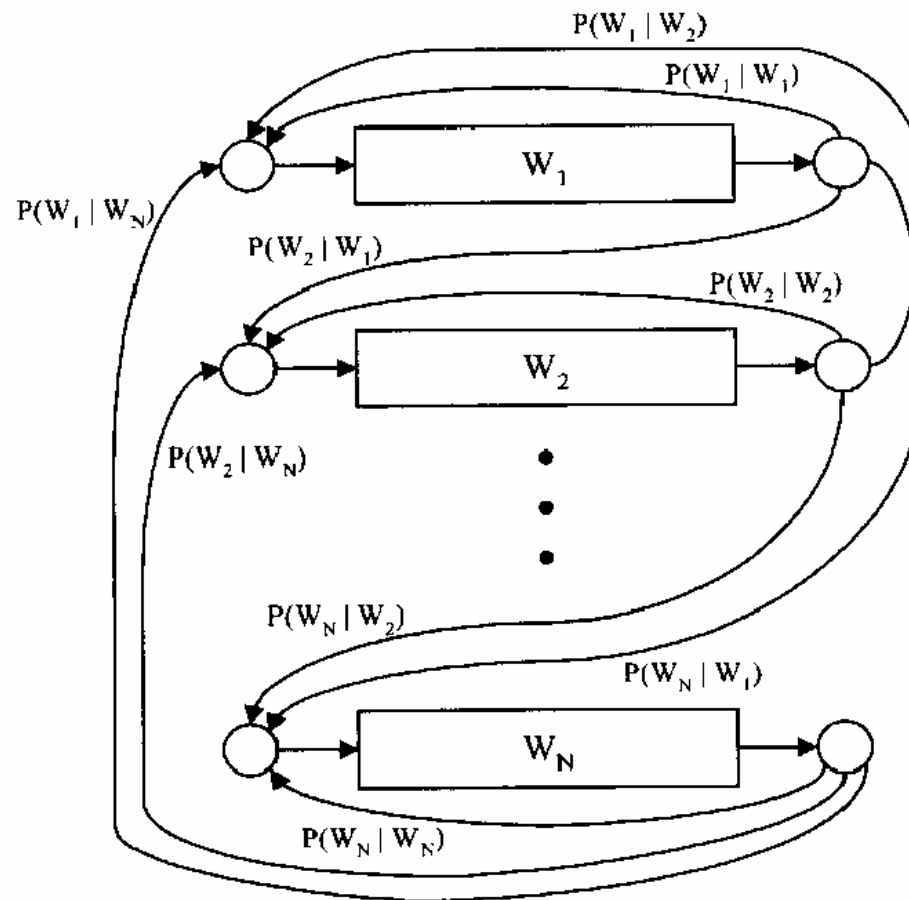
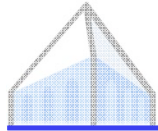

Figure from Huang et al page 618



State Space

- State space must include
 - Current word ($|V|$ on order of 20K+)
 - Index within current word ($|L|$ on order of 5)

- Acoustic probabilities only depend on phone type
 - E.g. $P(x|\text{lec}[t]\text{ure}) = P(x|t)$

- From a state sequence, can read a word sequence

State Refinement

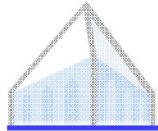

Phones Aren't Homogeneous

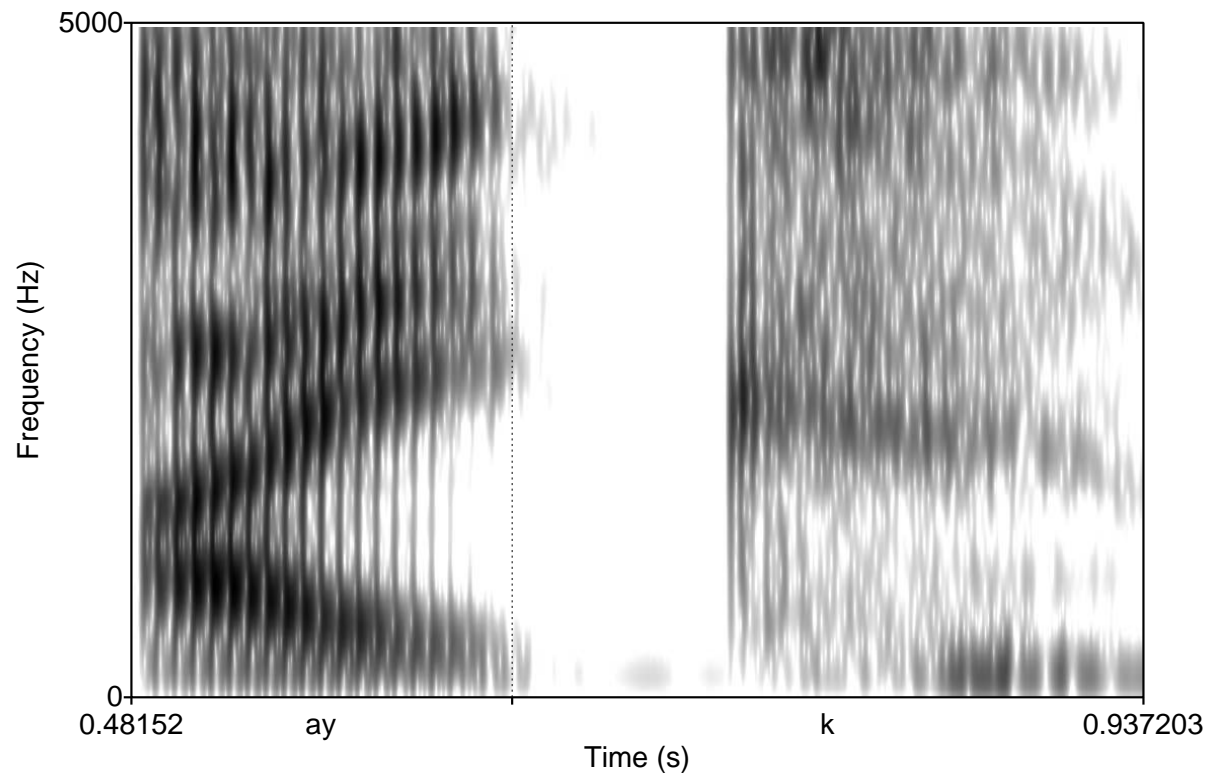

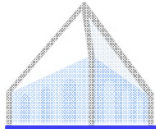

Need to Use Subphones

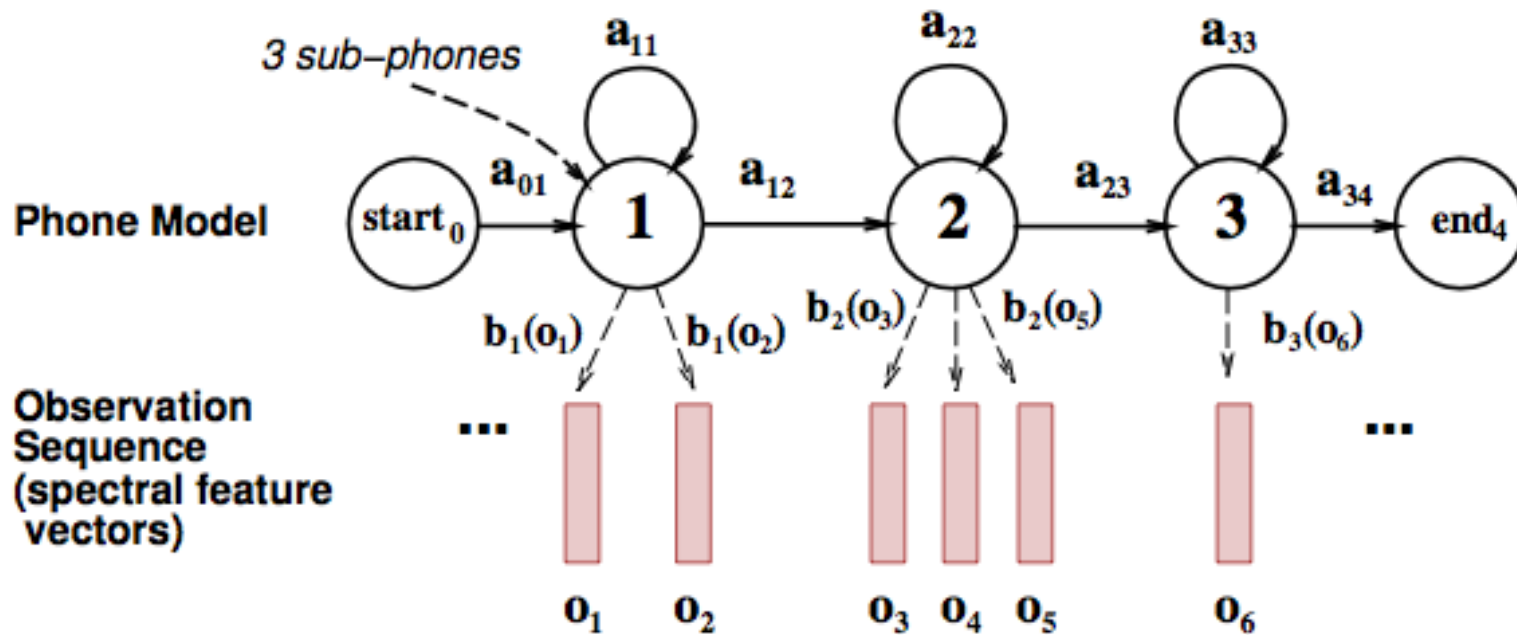
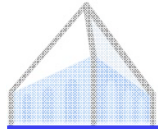

Figure: J & M



A Word with Subphones

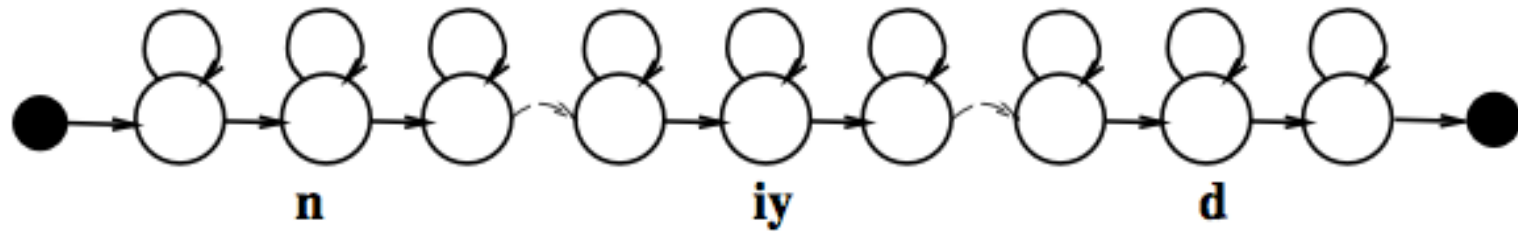
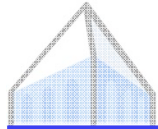
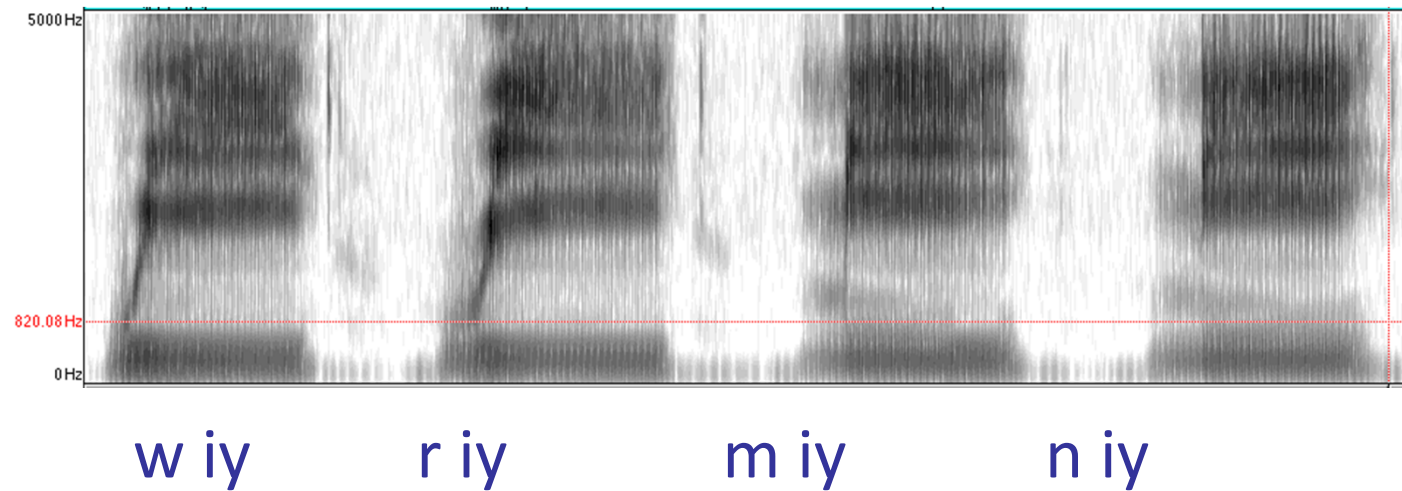
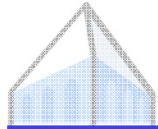

Figure: J & M



Modeling phonetic context





“Need” with triphone models

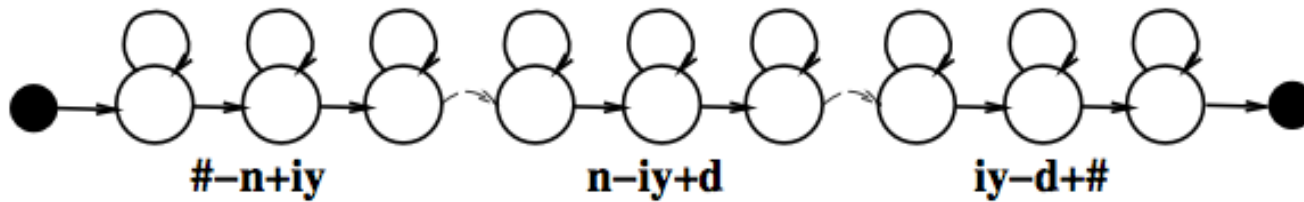
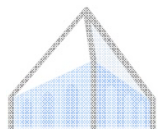
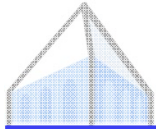

Figure: J & M



Lots of Triphones

- Possible triphones: $50 \times 50 \times 50 = 125,000$
- How many triphone types actually occur?
- 20K word WSJ Task (from Bryan Pellom)
 - Word internal models: need 14,300 triphones
 - Cross word models: need 54,400 triphones
- Need to generalize models, tie triphones



State Tying / Clustering

- [Young, Odell, Woodland 1994]
- How do we decide which triphones to cluster together?
- Use **phonetic features** (or 'broad phonetic classes')
 - Stop
 - Nasal
 - Fricative
 - Sibilant
 - Vowel
 - lateral

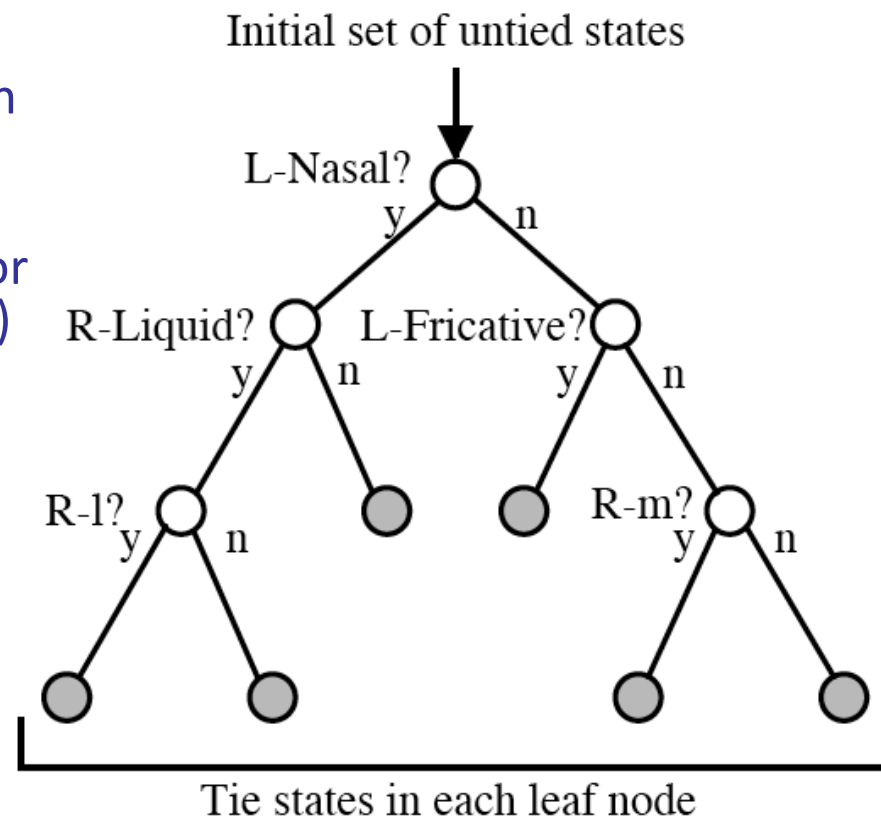
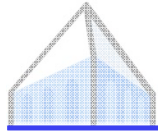

Figure: J & M



State Space

- State space now includes
 - Current word: $|W|$ is order 20K
 - Index in current word: $|L|$ is order 5
 - Subphone position: 3
- Acoustic model depends on clustered phone context
 - But this doesn't grow the state space

Decoding

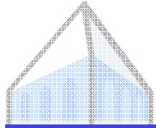

Inference Tasks

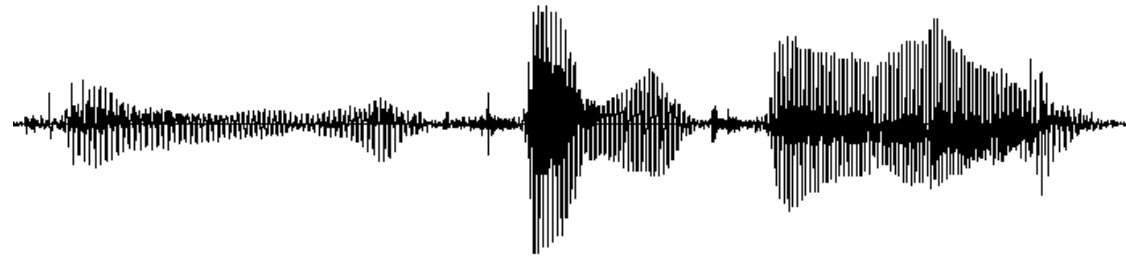

Most likely word sequence:

d - ae - d

Most likely state sequence:

$d_1-d_6-d_6-d_4-ae_5-ae_2-ae_3-ae_0-d_2-d_2-d_3-d_7-d_5$

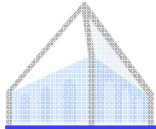

Viterbi Decoding

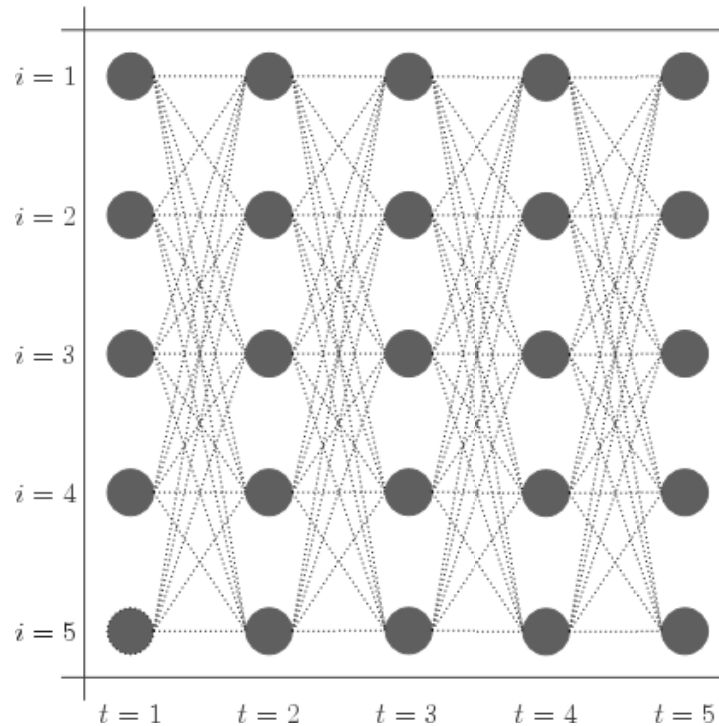

$$\phi_t(s_t, s_{t-1}) = P(x_t|s_t)P(s_t|s_{t-1})$$

$$v_t(s_t) = \max_{s_{t-1}} \phi_t(s_t, s_{t-1})v_{t-1}(s_{t-1})$$

Figure: Enrique Benimeli

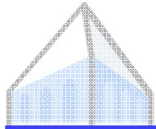

Viterbi Decoding

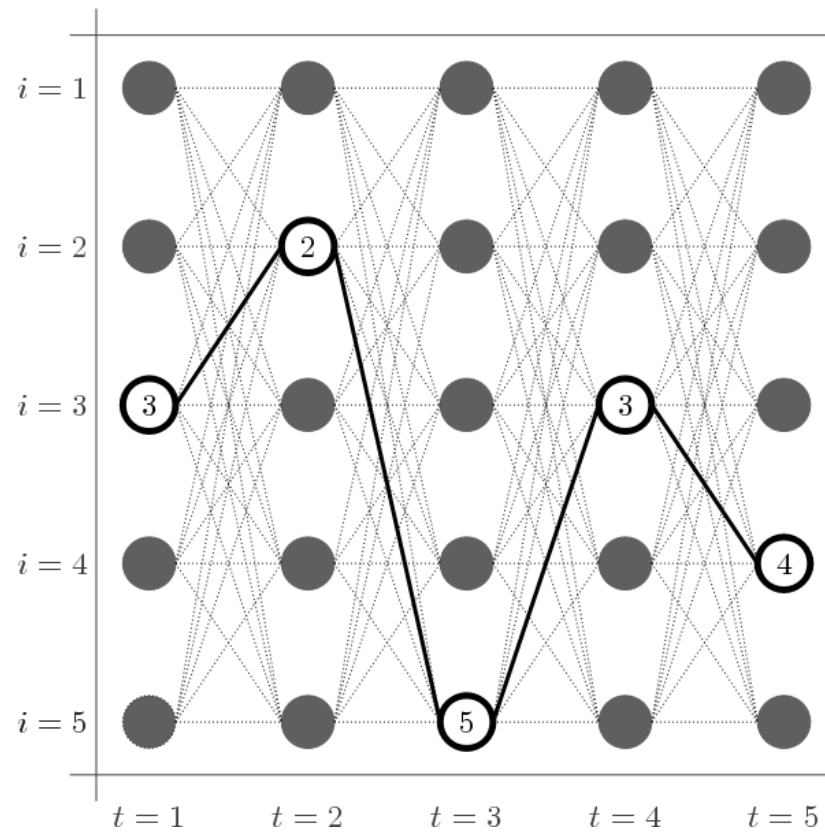
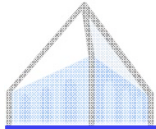
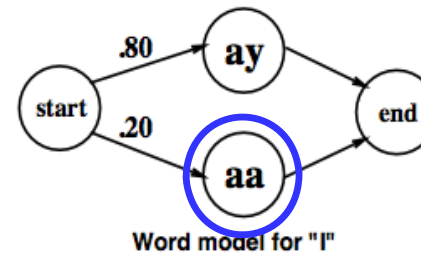
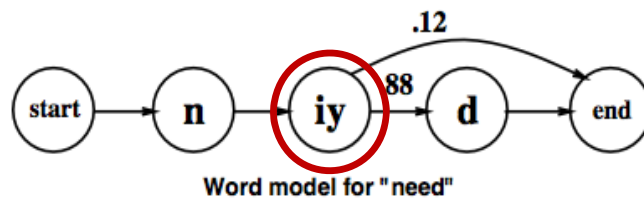
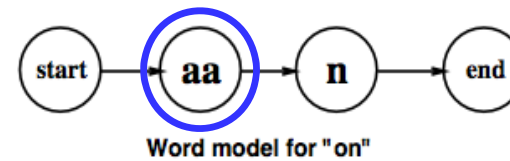
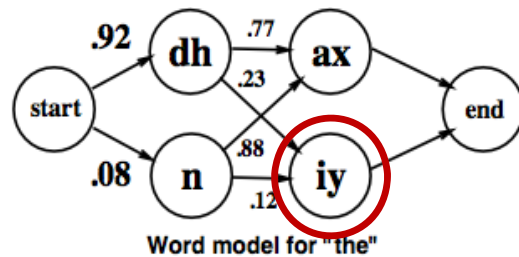

Figure: Enrique Benimeli



Emission Caching

- Problem: scoring all the $P(x|s)$ values is too slow
- Idea: many states share tied emission models, so cache them



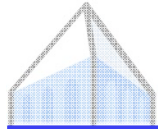

Prefix Trie Encodings

- Problem: many partial-word states are indistinguishable
- Solution: encode word production as a prefix trie (with pushed weights)

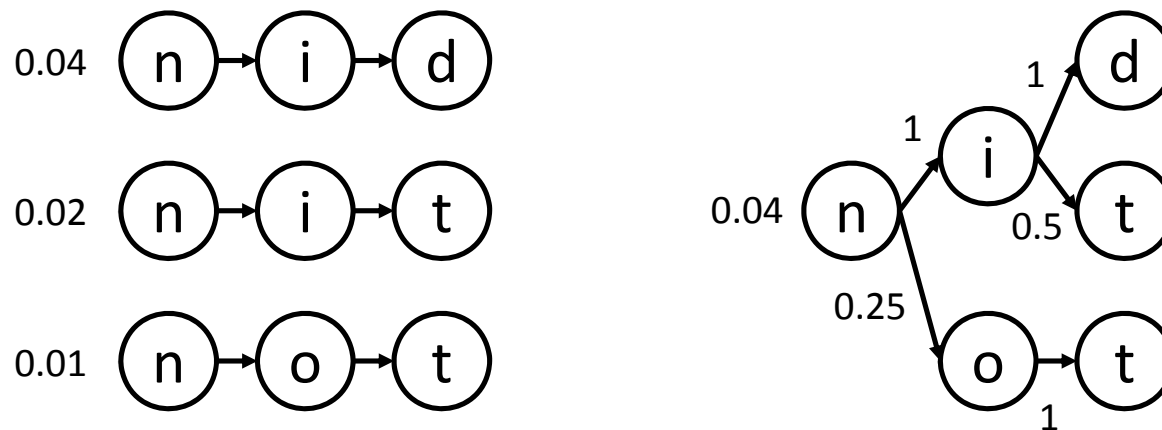

- A specific instance of minimizing weighted FSAs [Mohri, 94]

Figure: Aubert, 02

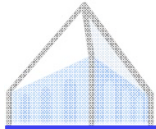

Beam Search

- Problem: trellis is too big to compute $v(s)$ vectors
- Idea: most states are terrible, keep $v(s)$ only for top states at each time

the b.
the m.
and then.
at then.

the ba.
the be.
the bi.

the ma.
the me.
the mi.

then a.
then e.
then i.

the ba.
the be.
the ma.
then a.



- Important: still dynamic programming; collapse equiv states

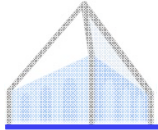

LM Factoring

- Problem: Higher-order n-grams explode the state space
- (One) Solution:
 - Factor state space into (word index, lm history)
 - Score unigram prefix costs while inside a word
 - Subtract unigram cost and add trigram cost once word is complete

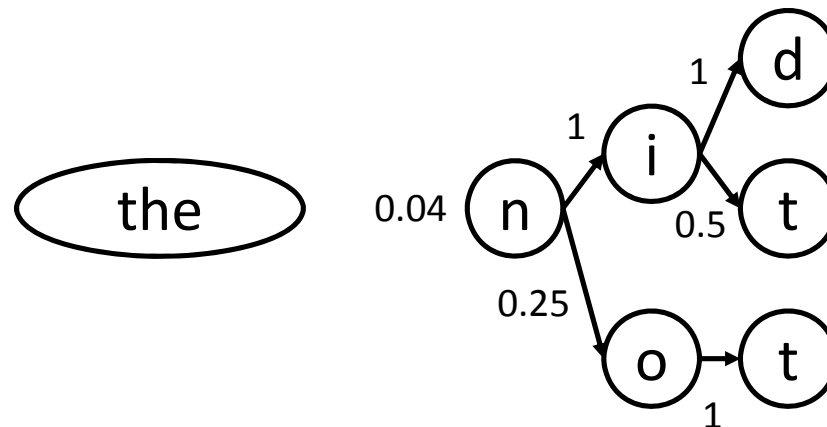

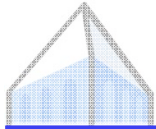

LM Reweighting

- Noisy channel suggests

$$P(x|w)P(w)$$

- In practice, want to boost LM

$$P(x|w)P(w)^\alpha$$

- Also, good to have a “word bonus” to offset LM costs

$$P(x|w)P(w)^\alpha|w|^\beta$$

- These are both consequences of broken independence assumptions in the model