



(12) **United States Patent**  
**Eldridge**

(10) **Patent No.:** **US 6,837,830 B2**  
(45) **Date of Patent:** **Jan. 4, 2005**

(54) **APPARATUS USING MULTI-DIRECTIONAL RESISTANCE IN EXERCISE EQUIPMENT**

(76) **Inventor:** **Mark W. Eldridge**, P.O. Box 70, 816 Hwy. 11 C, Brasher Falls, NY (US) 13613

(\*) **Notice:** Subject to any disclaimer, the term of this patent is extended or adjusted under 35 U.S.C. 154(b) by 236 days.

(21) **Appl. No.:** **10/286,279**

(22) **Filed:** **Nov. 1, 2002**

(65) **Prior Publication Data**

US 2004/0087418 A1 May 6, 2004

(51) **Int. Cl.<sup>7</sup>** ..... **A63B 22/00**

(52) **U.S. Cl.** ..... **482/54**

(58) **Field of Search** ..... 482/51, 54, 14, 482/39, 66, 121-124, 145, 111, 112

(56) **References Cited**

**U.S. PATENT DOCUMENTS**

1,364,699 A *	1/1921	Brown	482/54
2,017,128 A *	10/1935	O'Neill, Jr.	482/54
4,256,302 A	3/1981	Keiser et al.	
4,354,676 A	10/1982	Ariel	
4,544,154 A	10/1985	Ariel	
4,625,962 A *	12/1986	Street	482/116
4,645,201 A	2/1987	Evans	
4,915,373 A	4/1990	Walker	
5,145,481 A	9/1992	Friedebach	
5,167,601 A	12/1992	Frappier	

5,328,422 A *	7/1994	Nichols	482/52
5,385,519 A	1/1995	Hsu et al.	
5,385,520 A	1/1995	Lepine et al.	
5,444,812 A *	8/1995	Thibodeau	388/840
5,518,480 A	5/1996	Frappier	
5,876,308 A	3/1999	Jarvie	
5,941,804 A	8/1999	Johnston et al.	
6,120,416 A	9/2000	Walker	
6,123,649 A *	9/2000	Lee et al.	482/54
6,126,575 A *	10/2000	Wang	482/54
6,146,315 A *	11/2000	Schonenberger	482/69
6,186,290 B1	2/2001	Carlson	
6,231,484 B1	5/2001	Gordon	
6,234,935 B1	5/2001	Chu	
6,413,195 B1	7/2002	Barzelay	

\* cited by examiner

*Primary Examiner*—Stephen R. Crow

(74) *Attorney, Agent, or Firm*—Michael P. Williams; Bond, Schoeneck & King, PLLC

(57) **ABSTRACT**

An exercise apparatus includes a frame for supporting all the components of the apparatus and a multi-directional resistance means for providing a user of the apparatus the ability to duplicate actual athletic procedures. The apparatus includes a treadmill for the user to operate with the multi-directional resistance means and at least two connection means between the user legs the multi-directional resistance means. A front bar is mounted on the frame for the user to hold onto while duplicating an athletic procedure. Finally, there is a controlling means to adjust the multi-directional resistance means for changing the effect of the users' workout.

**29 Claims, 6 Drawing Sheets**

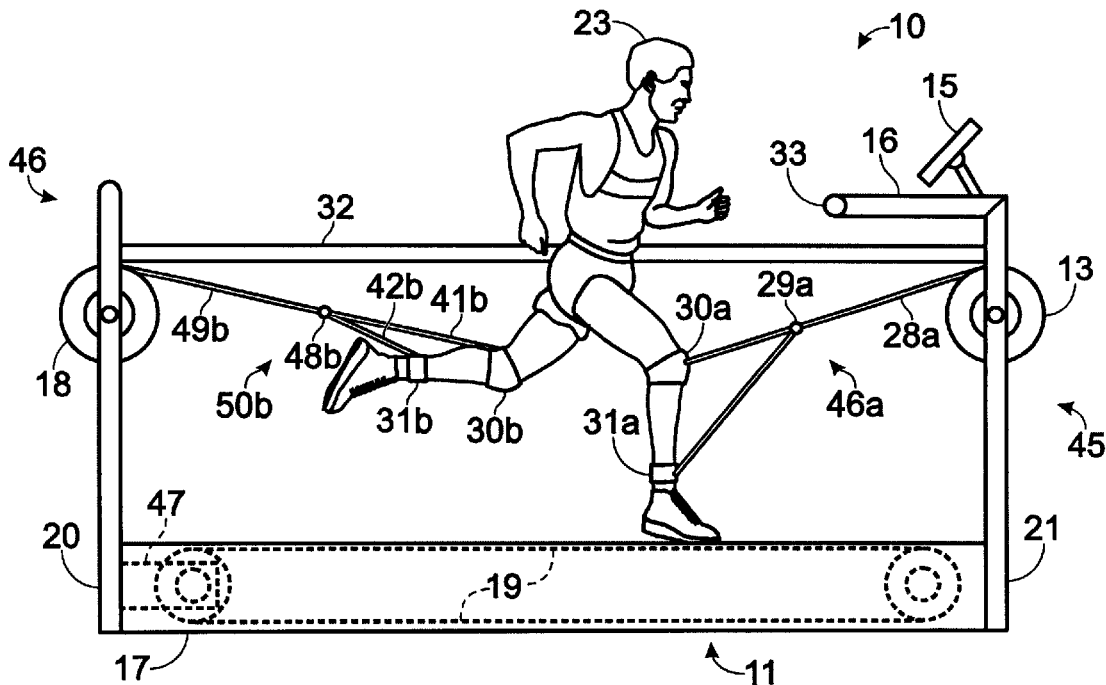

Fig. 1

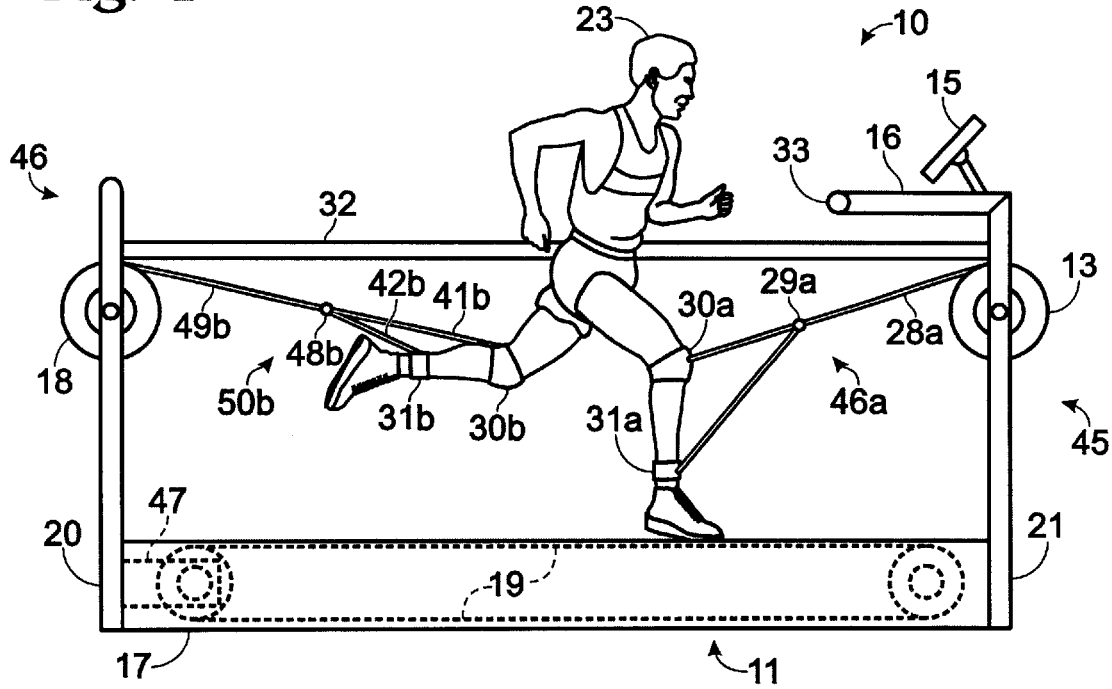
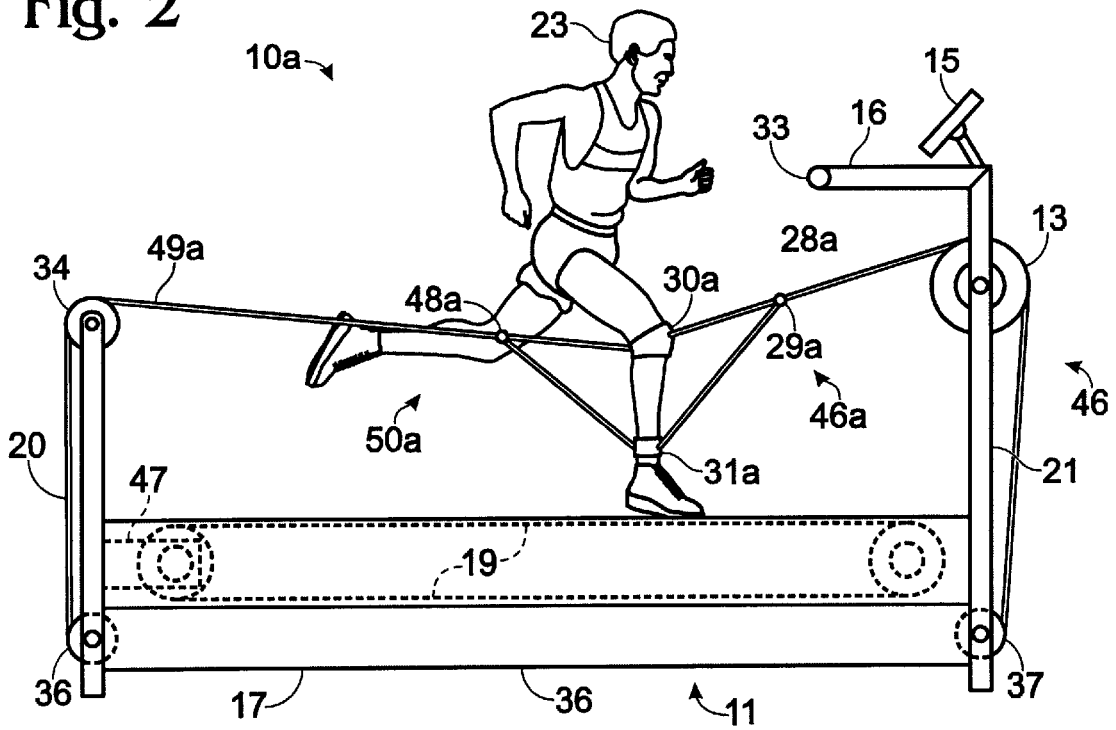

Fig. 2



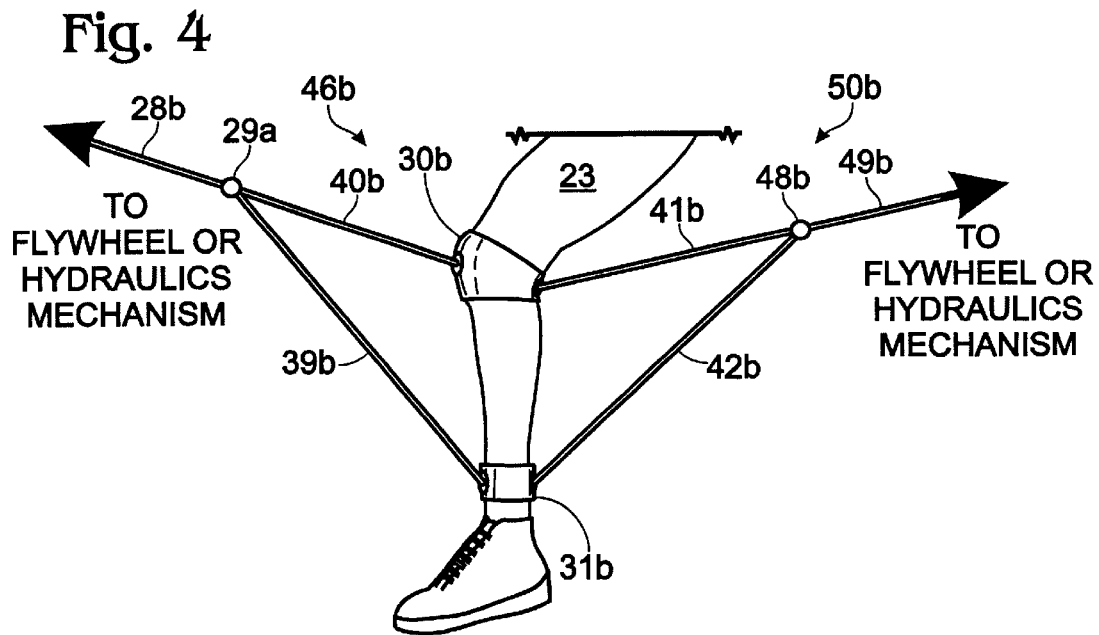
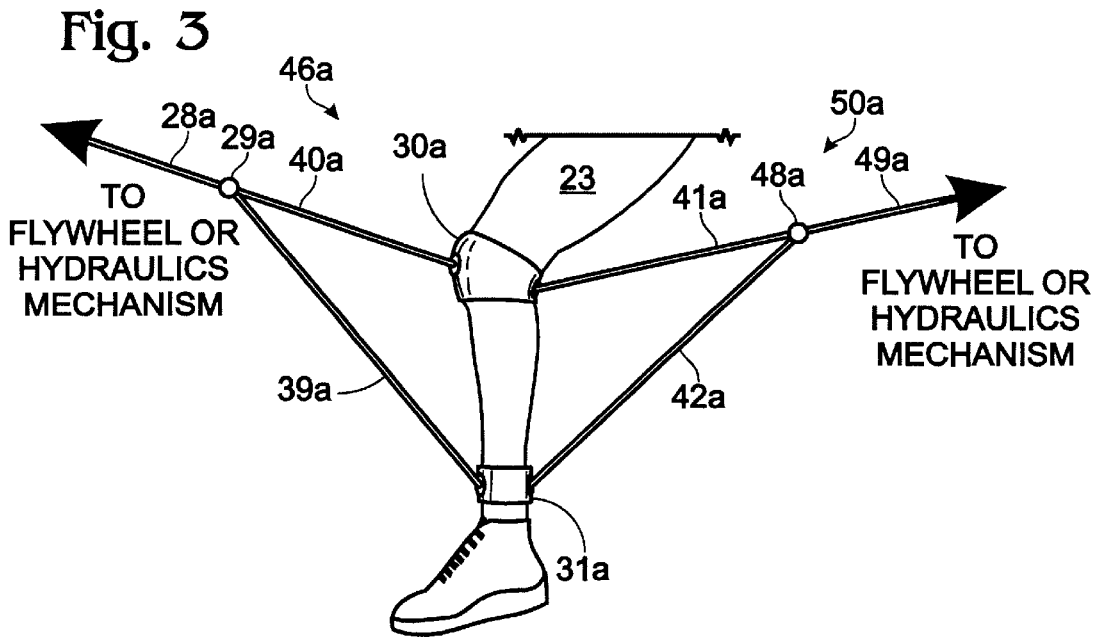

Fig. 5

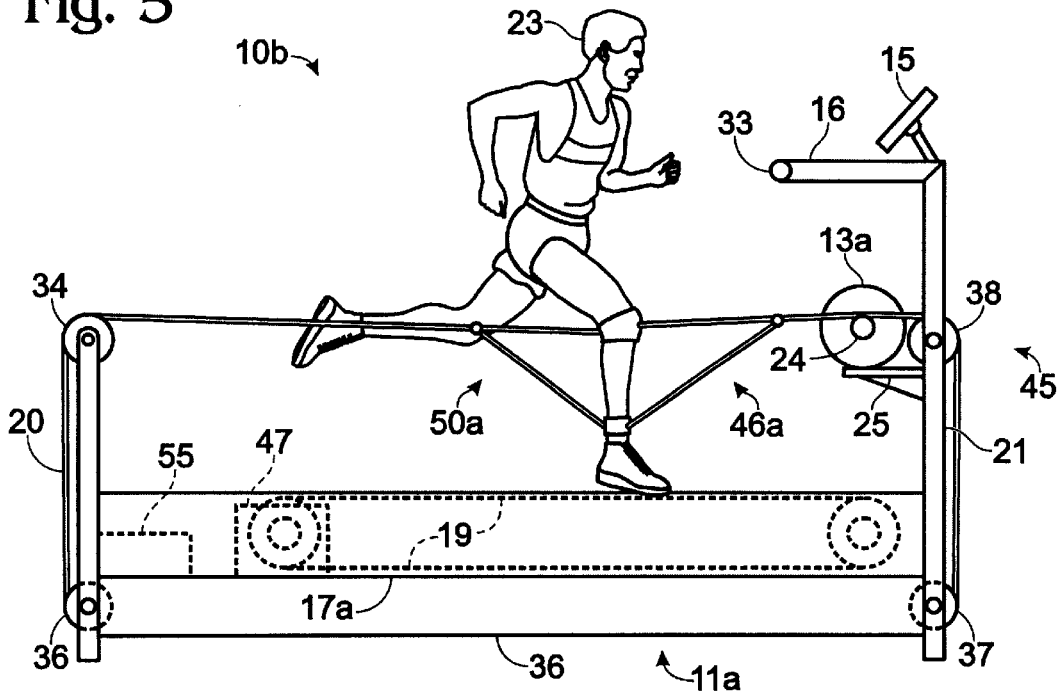

Fig. 5A

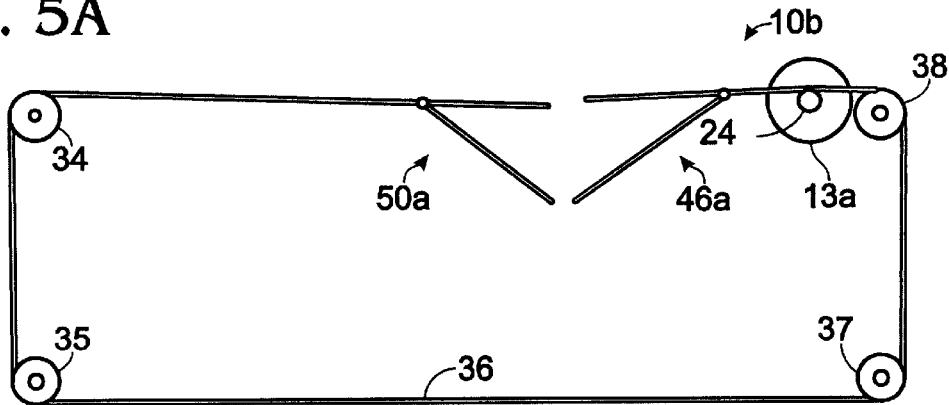

Fig. 5B

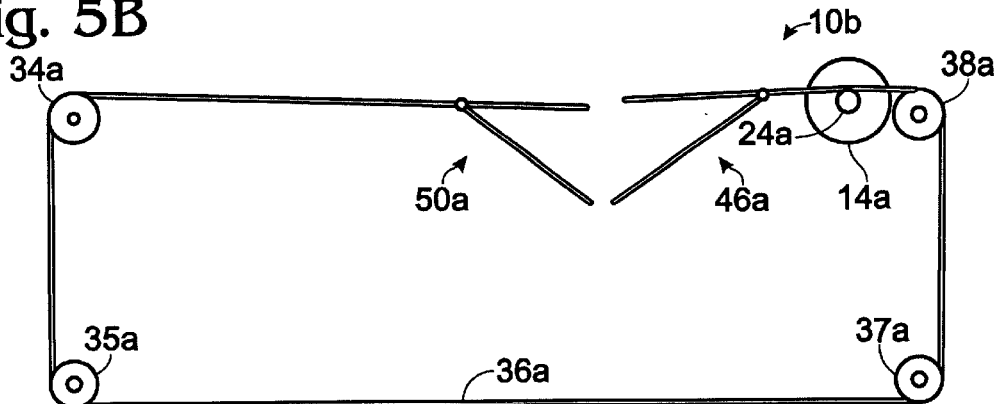

Fig. 6A

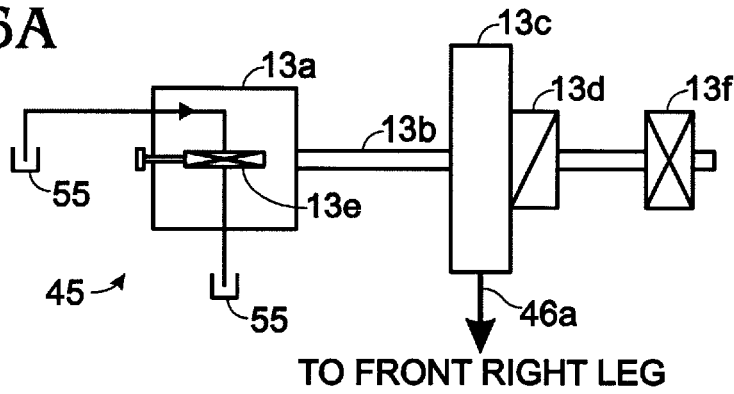

Fig. 6B

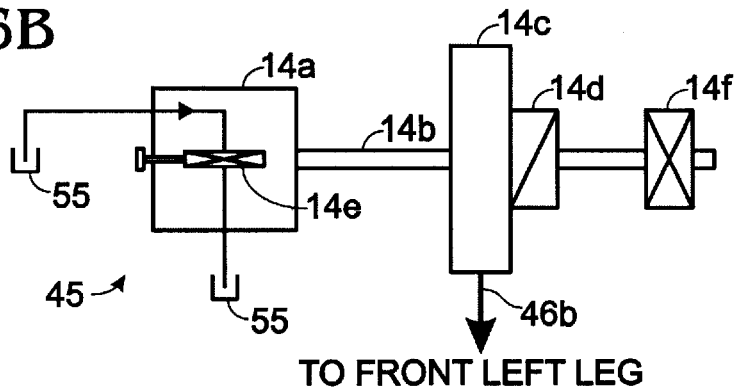

Fig. 6C

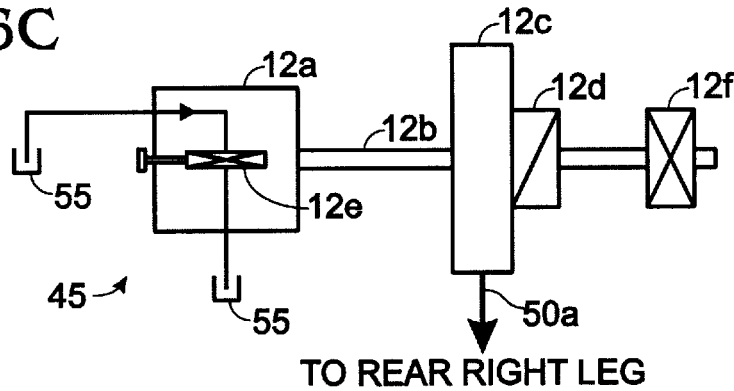

Fig. 6D

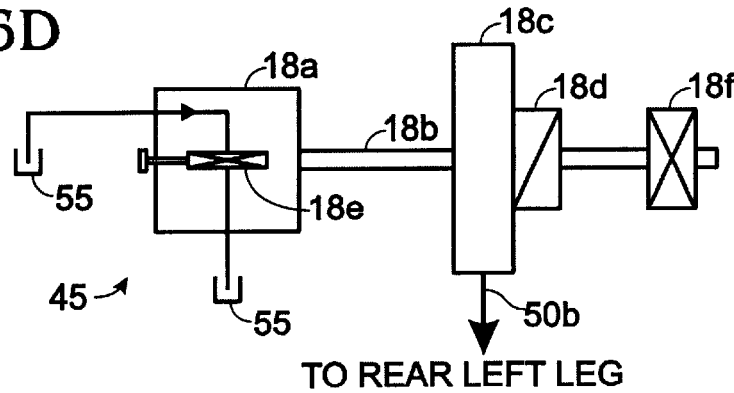

Fig. 7A

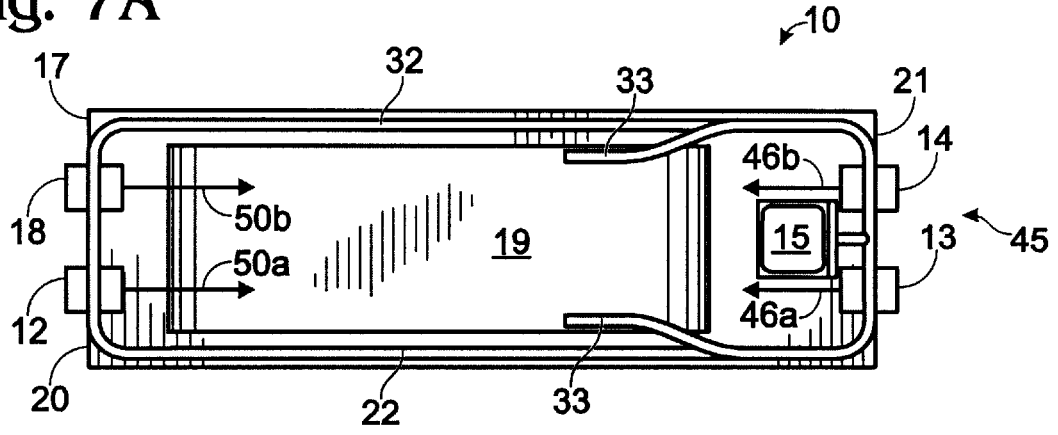

Fig. 7B

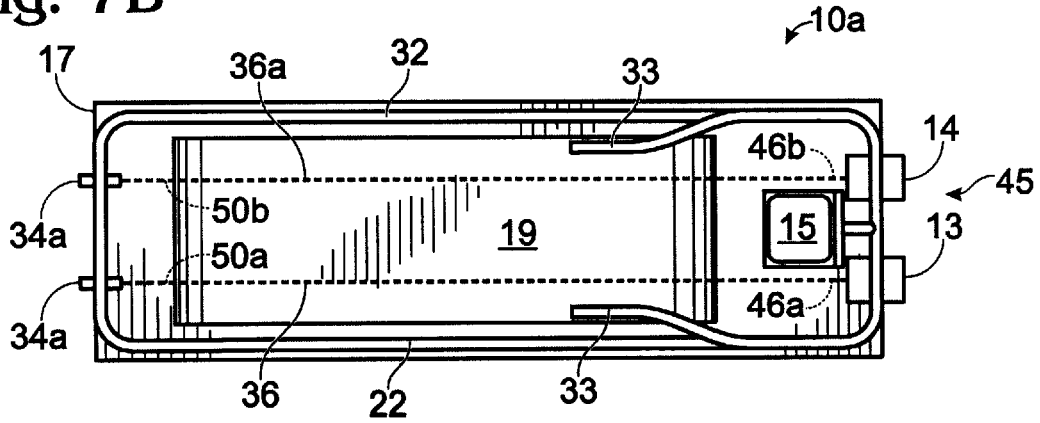

Fig. 7C

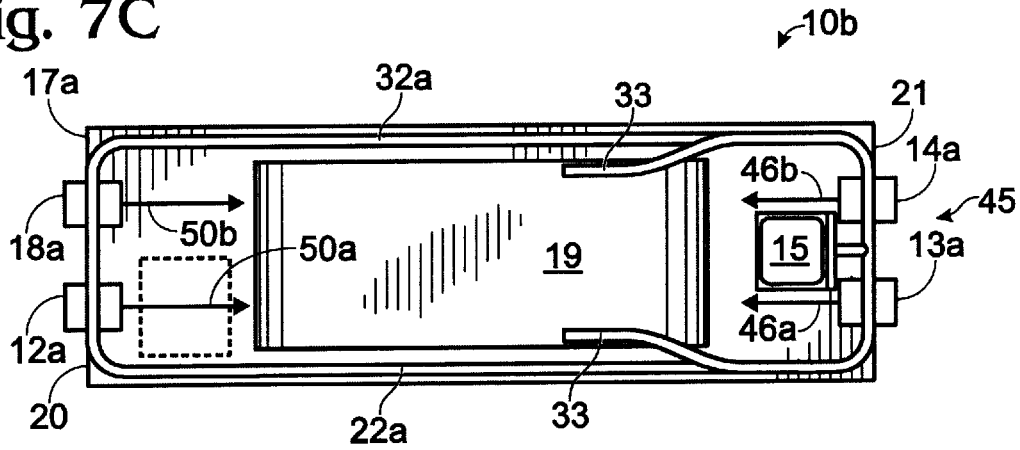

Fig. 8

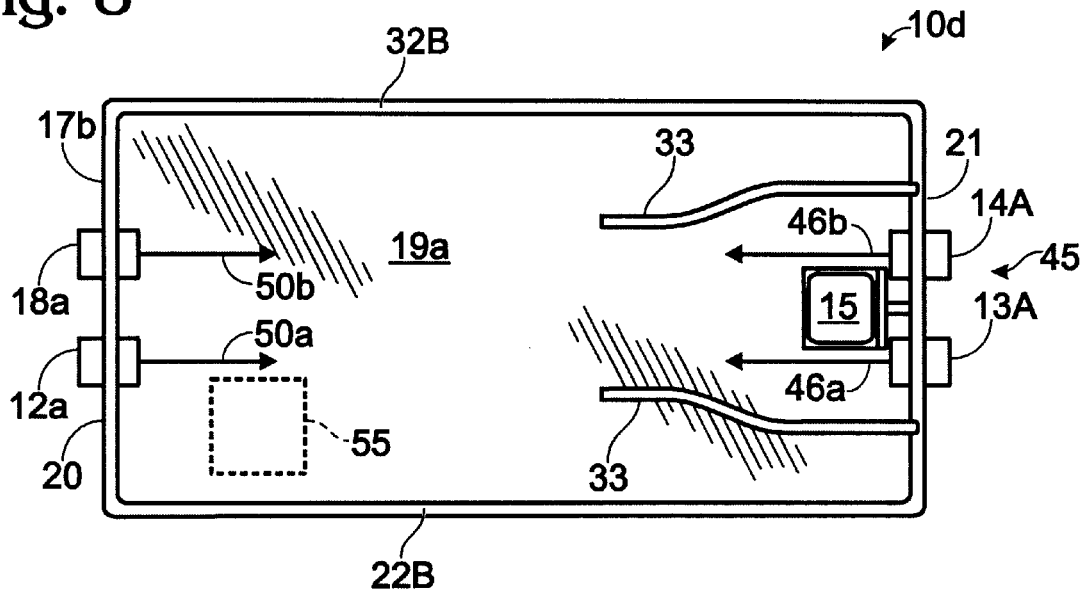
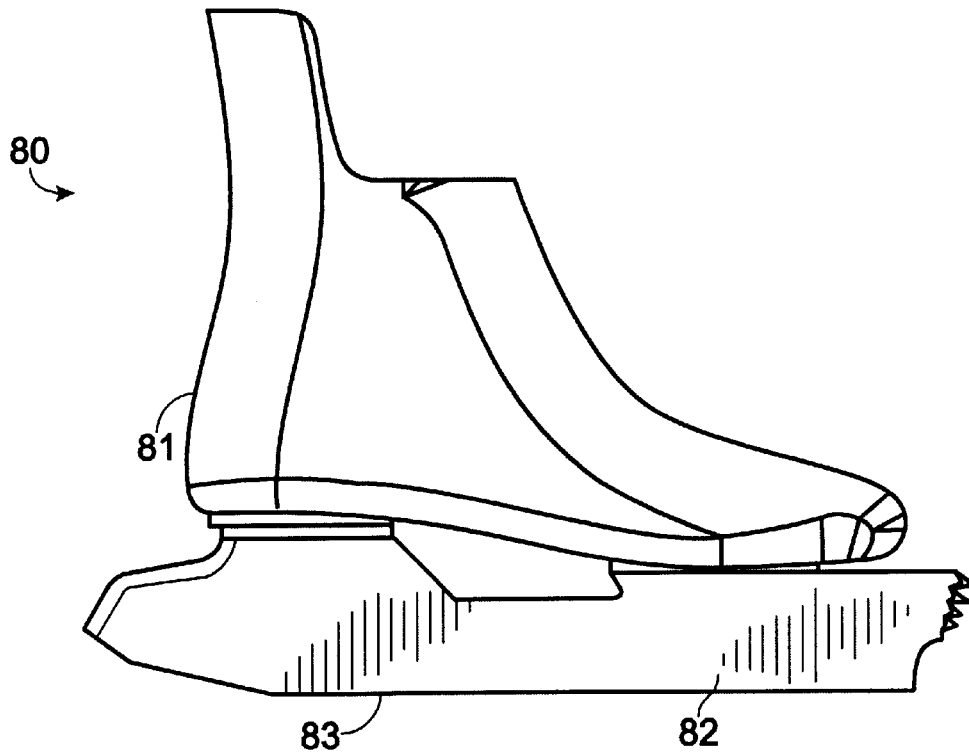

Fig. 9



## APPARATUS USING MULTI-DIRECTIONAL RESISTANCE IN EXERCISE EQUIPMENT

### FIELD OF THE INVENTION

This invention relates to exercise equipment and a method of operating the same, and more particularly to the use of multi-directional resistance in an exercise machine that allows the user to duplicate actual athletic procedures.

### BACKGROUND OF THE INVENTION

Maintaining proper fitness is a growing concern for many Americans. The medical community has become increasingly aware in the value of exercise to the overall health of an individual. Furthermore, athletes need regular and stringent workouts to maintain their abilities. As a result, more and more individuals are committed to a routine of regular exercise. However, it is difficult for many to devote a great amount of time in their regular exercise routine. Also, many prefer to workout in the home instead of a gymnasium because this provides the flexibility of working out when a schedule allows the time. Simultaneously, there is a demand for exercise equipment that is capable of providing an effective stringent workout with the ability to duplicate athletic routines.

As is known by the practitioner in the art, a conventional running exercise machine uses rotary potentiometers installed on the consoles in front of the machines. These potentiometers will vary the speed of the machine allowing the user to run faster or slower. However, the only resistance provided by this kind of running machine is through the tilt of the running machine platform. If the user wants a harder workout then the user will raise the incline of the platform simulating the resistance of the incline of a hill. Also, if the user desires an easier workout they will lower the incline of the platform. The problem with this type of resistance in the running machine is that there is a limited range and direction of resistance for increasing the strength of a users' lower extremities or duplicating athletic procedures.

The running machine described in U.S. Pat. No. 5,444, 812, entitled "Automatic Speed Servo-Control Apparatus For Electrically Powered Walking-Running Exercise Machine," to Thibodeau, is confined to a speed servo-control for a user to walk/run on a moving belt with a direct current drive input that controls the speed of the moving belt. A cord assembly includes a belt that is tied around the users' waist and connected to a control unit that allows the user to increase or decrease the speed of the moving belt. The apparatus does not provide the user with multi-directional resistance and control to their legs providing for appropriate proprioceptive neuromuscular facilitation within the specific musculature. The user is limited in their ability to strengthen their legs and stride and cannot duplicate athletic procedures.

In another exercise machine as described in U.S. Pat. No. 5,385,520, entitled "Ice Skating Treadmill," to Lepine et al., some of the protocols for the biomechanics of ice skating are duplicated in an ice skating treadmill. The ice skating treadmill relies on a lubricated rotatable surface providing a coefficient of friction close to that of natural ice. The ice skating treadmill allows natural ice skating behavior in a fixed position. However, this ice skating treadmill does not provide the capability to provide multi-directional resistance on the lower extremities in a correct biomechanical position. It does not provide for appropriate proprioceptive neuromuscular facilitation within the specific musculature duplicating

athletic procedures. The user is limited in their ability to strengthen their legs and stride.

What is needed is an exercise machine that will incorporate a multi-directional resistance means providing different levels of strengthening to the users' lower extremities and duplicating actual athletic procedures.

### SUMMARY OF THE INVENTION

It is an aspect of this invention to provide a running machine with a multi-directional resistance directed at the user, which allows a directed strengthening of the users' lower extremities by duplicating actual athletic procedures.

It is another aspect of this invention to provide an ice skating machine with a multi-directional resistance directed at the user, which allows a directed strengthening of the users' lower extremities by duplicating actual athletic procedures.

To accomplish these and other aspects of this invention an exercise apparatus includes a frame for supporting all the components of the apparatus and a multi-directional resistance means for providing a user of the apparatus the ability to duplicate actual athletic procedures. The apparatus includes a treadmill for the user to operate with the multi-directional resistance means and at least two connection means between the users' legs and the multi-directional resistance means. A front bar is mounted on the frame for the user to hold onto while duplicating an athletic procedure. Finally, there is a controlling means to adjust the multi-directional resistance means for changing the effect of the users' workout.

### BRIEF DESCRIPTION OF THE DRAWINGS

FIG. 1 shows a side view of the exercise apparatus using four flywheels as the resistance means in the preferred embodiment of the invention.

FIG. 2 shows a side view of the exercise apparatus using two flywheels as the resistance means in the preferred embodiment of the invention.

FIG. 3 shows a detailed view of the right knee and leg strap used in the preferred embodiment of the invention.

FIG. 4 shows a detailed view of the left knee and leg strap that is used in the preferred embodiment of the invention.

FIG. 5 shows a side view of the exercise apparatus using two hydraulic mechanisms as the resistance means in the preferred embodiment of the invention.

FIG. 5A illustrates the right side pulley set in the preferred embodiment of the invention.

FIG. 5B illustrates the left side pulley set in the preferred embodiment of the invention.

FIG. 6A illustrates the front right leg connection means and a hydraulic mechanism in the preferred embodiment of the invention.

FIG. 6B illustrates the front left leg connection means and a hydraulic mechanism in the preferred embodiment of the invention.

FIG. 6C illustrates the rear right leg connection means and a hydraulic mechanism in the preferred embodiment of the invention.

FIG. 6D illustrates the rear left leg connection means and a hydraulic mechanism in the preferred embodiment of the invention.

FIG. 7A illustrates the top view of the four flywheel application in the preferred embodiment of the invention.

FIG. 7B illustrates the top view of the two flywheel application in the preferred embodiment of the invention.

3

FIG. 7C illustrates the top view of the four hydraulic mechanism application in the preferred embodiment of the invention.

FIG. 8 illustrates the top view of an ice skating stationary deck used in one application of the preferred embodiment of the invention.

FIG. 9 shows a side view of an ice skate that is used in one application of the preferred embodiment of the invention.

#### DETAILED DESCRIPTION OF THE INVENTION

While the present invention is described below with reference to a running and skating machine, a practitioner in the art will recognize the principles of the present invention are applicable elsewhere.

FIG. 1 shows an exercise treadmill apparatus 10 in the preferred embodiment of the invention. A frame 11 supports all the components of the apparatus 10. This includes the treadmill platform 17, an endless belt 19, a multi-directional resistance means 45, a controlling means 15, a front bar 33, a left side bar 32 and a right side bar 22 (FIG. 7A). The front bar 33, similar in design to a bicycle handle bar, is for user 23 to hold onto while strengthening their stride and lower extremity muscles. A left sidebar 22 and a right sidebar 32 gives the user 23 the ability to do crossover strides and to duplicate actual athletic procedures when using the multi-directional resistance means 45.

The user 23 may operate the endless belt 19 in conjunction with the multi-directional resistance means 45 or may prefer not to operate the endless belt 19 when using the multidirectional resistance means 45. The multi-directional resistance means 45 provides the user 23 with the ability to strengthen their leg stride and muscles and duplicate actual athletic procedures. Furthermore, the multi-directional resistance means 45 provides either an isotonic or isokinetic resistance that is directly proportional to the intensity of effort applied by the user 23. The multi-directional resistance means 45 in apparatus 10 includes four flywheels each containing a magnetic brake, recoil and a one-way clutch. Alternately, the flywheels are substitutable with four hydraulic mechanisms each containing a recoil and a one-way clutch.

There are four connection means between the two legs of user 23 and the multi-directional resistance means 45. For example, the front right leg connection means 46a includes a right knee strap 30a, a right leg strap 31a, a first element 28a and a first rotatable structure 29a. Furthermore, the rear left leg connection means 50b includes a knee strap 30b, a leg strap 31b, a left leg second rotatable structure 48b, a left leg third segment 41b, a left leg fourth segment 42b and a left leg second element 49b. There also exists a rear right leg connection means 50a (FIG. 3) and a front left leg connection means 46b (FIG. 4).

A controlling means 15 provides the user 23 with the ability to independently control the force and direction of resistance from the multi-directional resistance means 45 and further independently control the speed and tilt of the treadmill 19. The controlling means 15 provides the user 23 with the ability to regulate the intensity of their workout, switch between isotonic and isokinetic resistance (constant force or maximum speed) and assist in the duplication of athletic procedures. The controlling means 15 panel is positioned on mounting structure 16.

The endless belt 19 is adaptable to a variety of applications including, but not limited to, a running treadmill and an ice skating treadmill. If apparatus 10 is a running treadmill,

4

the endless 19 users a rubberized endless belt slightly less than the width of the treadmill platform 17, wherein the platform is about 2 to 3 feet in width. The rubberized polyester belt will contain parallel ridges, from side-to-side of the belt, all the way around the endless belt 19. The ridges will provide to the user 23 a non-slip surface so that they may safely exercise using apparatus 10. The belt tension on the endless belt 19 is adjustable on the treadmill platform 17 to provide a properly fitted belt to the treadmill. The endless belt 19 contains a motor/drive arrangement 47 mounted inside the treadmill platform 17. The motor drive arrangement is a typical arrangement as known by the practitioner in the art. However, the treadmill motor/drive 47 will provide an endless belt 19 speed from about zero to 28 mph. Alternately, the endless belt 19 further consists of the proper mechanical connections with the motor 47 to allow the endless belt 19 to be freewheeling, that is, the endless belt will move independent of the motor 47. Furthermore, a servo-motor adjusts the elevation of the endless belt 19 as is typically used in the art. The user 23 regulates the speed and elevation of the endless belt 19 from the panel of the controlling means 15. The adjustment of the endless belt 19 is accomplished by use of a potentiometer as is typical in the art. However, the endless belt 19 speed is also controllable by the use of a variable speed DC motor and hardware in other applications. This includes an AC to DC inverter so that the treadmill is conveniently plugged into any home 110 VAC outlet.

If apparatus 10 is an ice skating treadmill, the endless belt 19 users a ultra high molecular weight (UHMW) polyethylene endless surface belt that is slightly less than the width of the treadmill platform 17. The endless belt 19 width for an ice skating exercise machine is usually about eight feet wide, but the width varies depending on the ice skating application. The ice skating endless belt 19 is typically wider than the running endless belt 19 to accommodate the sideward motion of an ice skating stride. Alternately, the ice skating treadmill is substitutable for an ice skating cover 19c using a stationary platform 17c as illustrated in FIG. 8 instead of the endless belt. Typically, the stationary platform surface 17c uses a cover 19c comprised of UHMW polyethylene. However, any high density plastic with UHMW polyethylene characteristics is substitutable for UHMW polyethylene for use as the material of construction for the endless belt 19 or cover 19c. The endless belt 19 and cover 19c are covered with a flexible UHMW polyethylene. Furthermore, the cover 19c surface is used in combination with the polytetrafluoroethylene coated ice skates 80 (FIG. 9) to provide a coefficient of friction similar to that of natural ice. The endless belt 19 or cover 17c are operated in conjunction with the user 23 wearing ice skates 80 having boots 81 and blades 83 that are polytetrafluoroethylene coated 82 as shown in FIG. 9.

When apparatus 10 is an ice skating treadmill the treadmill motor/drive 47 provides a variable endless belt 19 speed from about zero to 28 mph. The variable speed is accomplished by a potentiometer as is known by the practitioner in the art. However, the potentiometer is substitutable for a variable DC motor and hardware. This includes an AC to DC inverter so that the treadmill is conveniently plugged into any home 110 VAC outlet. A servo-motor is used to adjust the elevation of the endless belt 19 to provide the user 23 with the simulation of skating uphill. The user 23 regulates the speed and elevation of the endless belt 19 from the panel of the controlling means 15. The controlling means 15 allows the endless belt 19 to work in a forward movement and a backward movement and includes an AC to DC

5

inverter and the necessary electrical devices. A forward movement allows the user **23** to exercise their leg muscles and stride simulating forward skating while the backward movement allows the user **23** to exercise their leg muscles and stride simulating reverse skating. The forward movement and backward movement is accomplished by a switch or other means located at the panel of the controlling means **15** reversing motor polarity through the proper electronic circuitry. Alternately, the endless belt **19** further consists of the proper mechanical connections with the motor **47** to allow the endless belt **19** to be freewheeling, that is, the endless belt will move independent of the motor **47**. The endless belt **19** speed is variable with the forward movement and the backward movement. Finally, the endless belt **19** incline adjustment is located at the controlling means **15**.

The multi-directional resistance means **45** changes to and from isotonic resistance and isokinetic resistance (constant force or maximum speed) by using the controlling means **15**. In the preferred embodiment of the invention the multi-directional resistance means **45** and endless belt **19** speed and tilt are independently controlled. The multi-directional resistance means **45** consists of a first flywheel **13** and a second flywheel **14** (FIG. 7A) mounted at the front **21** of frame **11**. The multi-directional resistance means **45** further includes a third flywheel **12** (FIG. 7A) and a fourth flywheel **18** mounted at the rear **20** of frame **11**. Each multi-directional resistance means **45** not only includes a flywheel but further includes a magnetic brake, recoil and a one way clutch. The user **23** will be strapped to the four flywheels with four connection means by four points at front of their legs and by four points at the rear of their legs. For example, resistance is generated on the user's **23** right leg from the first flywheel **13** by the user **23** pulling their right leg backward away from the first flywheel **13** using the front right leg connection means **46a**. At the same time as the user's **23** right leg moves away from the first flywheel **13** their right leg moves toward the third flywheel **12** (FIG. 7A), wherein the recoil of the third flywheel **12** coils the rear right leg connection means **50a** (FIG. 3). In the next move, as the user **23** pulls their right leg away from the third flywheel **12** the resistance from the third flywheel **12** is applied to the user's **23** right leg using the rear right leg connection means **50a** (FIG. 3). At the same time as the user's **23** right leg moves away from the third flywheel **12** their right leg moves back toward the first flywheel **13**, wherein the recoil of first flywheel **13** coils the front right leg connection means **46a**. Furthermore, the user's **23** left leg has resistance generated from the second flywheel **14** and the fourth flywheel **18** similar to the resistance generated for the user's right leg.

The magnetic brake is an electric particle magnet but is substitutable for one that is a hybrid with hysteresis and eddy flow. The magnetorheological device combines a rotary brake with a flywheel thereby providing resistance and rotational inertia. A rotor rotates around a stationary member of the rotary brake and supports the generation of a magnetic field. The resistance to rotation is generated and controlled by applying a magnetic field to a pole and a medium disposed between the rotor and stationary member. The amount of resistance from the multi-directional resistance means **45** is varied by the controlling means **15** through the appropriate electrical circuits. As an alternative, the multi-directional resistance means **45a** is comprised of two flywheels as shown in apparatus **10a** in FIG. 2.

The first, second, third and fourth flywheels are each connected to user **23** by the various connection means. The first flywheel **13** is connected by a front right leg connection means **46a** to the front of the right leg and knee of user **23**.

6

The second flywheel **14** is connected by a front left leg connection means **46b** to the front of the left leg and knee of user **23** as shown in FIG. 4. The third flywheel **12** is connected by a rear left leg connection means **50b** to the back of the left leg and knee of user **23**. Also, the fourth flywheel **18** is connected by a rear right leg connection means **50a** to the back of the right leg and knee of user **23** as shown in FIG. 3.

In the apparatus **10** of FIG. 1, the multi-directional resistance means **45** is adjustable providing increased or decreased resistance to the users' leg muscles. First, the force (lbs.) of resistance or torque is adjustable in small increments by a switch, typically by a push of a button, located in the panel of the control means **15**. The force of resistance is controlled by a constant force of resistance with no relationship to the speed or incline of the endless belt **19**. Alternately, the force of resistance is controlled by a constant speed setting of the endless belt **19** with the force of resistance automatically adjusting to maintain a top maximum speed. However, the maximum speed may be set independently from the endless belt. A gauge that is located in the panel of the control means **15** will be able to record the force of resistance which the user is operating when the machine is in any mode of resistance.

The frame **11** of apparatus **10** is typically constructed of heavy gauge anodized aluminum. Other materials include, but are not limited to mild steel, stainless steel, plastic, and the like. Inside the treadmill platform **17** is mounted the treadmill motor/drive **47** and the required electrical circuitry including an inverter and transformer to convert 110 volts AC to 110 volts DC and 12 volts DC to operate the control means **15**. The motor is either AC or DC depending on the application. The potentiometer, or as an alternative the variable DC drive, is also located inside the treadmill platform **17**.

The endless belt **19** is attached to the sides of the treadmill platform **17** by means of take up bearing assemblies. The take up bearings are used to tension the endless belt **19**. In the ice skating treadmill a deck of infused wood on a shock absorbing base is mounted along the length and inside of the platform **17**. This provides a flat smooth bed that supports the entire endless belt **19** surface. The deck of infused wood is required because the width of the ice skating treadmill is typically about eight feet. In the running treadmill the endless belt **19** is supported by a smooth platform positioned underneath the belt and this gives the endless belt **19** a flat smooth bed on which to run. Finally, the controlling means **15** is mounted to the frame **11** by a mounting structure **16**.

The treadmill apparatus **10** has a stomach pad and/or bicycle handle bar type supports for the front bar **33** located at the front **21**. Furthermore, the treadmill apparatus **10** has a stomach pad or handle bar type supports at each side for the first side bar **22** and the second side bar **32**. The front bar **33**, the first side bar **22** and the second side bar **32** are used by user **23** as support on crossover strides of each leg on both side of the treadmill apparatus **10** and for the forward stride of each leg. Also, closed circuit cameras are mountable on the sides and rear **20** with the monitors visible to the user **23** in the front **21** of the treadmill **10** so that the user **23** can perfect and adjust their stride. Alternately, mirrors are substitutable for closed circuit cameras or can be used in conjunction with the closed circuits cameras for the user **23** to perfect their stride. Finally, the user will have a harness secured to them mounted on a frame that is built over the top of apparatus **10**. The harness will secure the user **23**, for example, when speed training at 28 mph, wherein the harness is for stopping the user **23** from flying off the treadmill **19**.

7

The controlling means **15** includes the electrical, safety and operational controls of apparatus **10**, including, but not limited to, the necessary relays and resistors for the system operation. The controlling means **15** includes a panel that incorporates main power switches, an emergency stop switch, a digital speed indicator, a heart rate monitor, and the like. For example, the controlling means **15** houses the electrical circuit to control the endless belt **19** in the forward movement and the backward movement when the treadmill **10** is an ice skating treadmill. The electrical circuit is operated by a switch mounted on the controlling means **15** panel. Resistance control for each flywheel in the form of a rotary switch or similar means is individually mounted on the controlling means **15** panel. As an alternative, one rotary switch or similar means provides the resistance control for all the flywheels. Further features include right and left endless belt **19** fault indicator lamps to indicate when the endless belt over tracks to one side. A drive fault indicator lamp is included to signal a drive problem. Also, a belt start/stop switch is used to activate the endless belt **19** while a rotary switch is used to select the desired speed of the belt. As is known by the practitioner in the art the rotary switches are replaceable by a digital system. Finally, the controlling means **15** allows the user **23** to individually regulate the resistance means **45** and the endless belt **19** speed to change the effect of the users' workout.

FIG. 2 shows an exercise treadmill apparatus **10a** with two flywheels in the preferred embodiment of the invention. A frame **11** supports all the components of the treadmill apparatus **10a**. This includes the treadmill platform **17**, the endless belt **19**, a multi-directional resistance means **45** and a front bar **33**. The front bar **33** is for the user **23** to hold onto while strengthening their stride. The multi-directional resistance means **45** consists of two flywheels each containing a magnetic brake, recoil and a one-way clutch. The user **23** has the ability to operate the endless belt **19** in conjunction with the multi-directional resistance means **45**. Alternately, the multi-directional resistance means **45** is independently controllable from the endless belt **19** control. A controlling means **15** provides the user **23** with the ability to speedup or slow down the endless belt **19** and incline or decline the endless belt **19**. The controlling means **15** provides the user **23** with the ability to regulate the intensity of their workout by adjusting the amount of resistance produced from the multi-directional resistance means **45**.

The treadmill apparatus **10a** is adaptable to a variety of applications including, but not limited to, a running treadmill and an ice skating treadmill. If apparatus **10a** is a running treadmill, the endless belt **19** uses a rubberized endless belt slightly less than the width of the treadmill platform **17**. The rubberized polyester belt will contain parallel ridges from side-to-side of the belt all the way around the endless belt **19**. The ridges will provide to the user a non-slip surface so that they may safely exercise using apparatus **10a**. Belt tension on the endless belt **19** is adjustable on the treadmill as is known by the practitioner in the art. The treadmill platform **17** contains a motor/drive arrangement **47** that is typical in the art and mounted inside the treadmill platform **17**. However, the motor/drive **47** provides an endless belt **19** speed from about zero to 28 mph. The user **23** regulates the speed of the endless belt **19** from the controlling means **15**. The controller for the endless belt **19** typically is accomplished by use of a potentiometer as is common in the art. The endless belt **19** speed is also controlled by the use of a variable speed DC motor and hardware in other applications. Furthermore, a servo-motor as is typically used in the art adjusts the elevation (incline)

8

of the endless belt **19** track. The user **23** regulates the speed and incline of the endless belt **19** from the panel of the controlling means **15**.

If apparatus **10a** is an ice skating treadmill, the endless belt **19** uses a ultra high molecular weight (UHMW) polyethylene endless surface belt slightly less than the width of the treadmill platform **17**. The width of the ice skating treadmill platform **17** is typically about eight feet, but this width is substitutable for any width that is desired. Alternately, the endless belt is substitutable for a stationary platform **19b** and cover **17b** as shown in FIG. 8. The cover **17b** on the stationary platform consists of UHMW polyethylene material. However, any high density plastic with UHMW characteristics is substitutable for the UHMW polyethylene material used in the construction of the endless belt **19** on the treadmill platform **17** and the cover **17b** on the stationary platform **19b**. The endless belt **19** on the treadmill platform **17** is covered with a flexible UHMW polyethylene. Furthermore, the endless belt **19** surface is used in combination with the polytetrafluoroethylene coated ice skates **80** (FIG. 9) to provide a coefficient of friction similar to that of natural ice. The endless belt **19** is used in conjunction with the user **23** wearing ice skates **80** with boots **81** and blades **83** that are polytetrafluoroethylene coated.

The controlling means **15** allows the endless belt **19** when operated as an ice skating treadmill to work in a forward movement and a backward movement. The controlling means **15** further includes an inverter and the necessary electrical devices. The forward movement allows the user **23** to exercise their stride simulating forward skating while the backward movement allows the user **23** to exercise their stride simulating reverse skating. Also, the controlling means **15** allows the endless belt **19** to speedup or slowdown using an adjustable motor/drive **47** to vary the speed. The variable speed is accomplished by a potentiometer as is known by the practitioner in the art. However, the potentiometer is substitutable for a variable DC motor and hardware. The forward movement and backward movement is accomplished by a switch or similar means located at the controlling means **15** panel that reverses motor polarity through electrical circuitry in the controlling means **15**. The endless belt **19** speed is variable with the forward movement and the backward movement. The endless belt **19** is also operable on an incline with the forward and the backward movement.

The multi-directional resistance means **45** through the controlling means **45** works in conjunction with the endless belt **19** or independent of the endless belt **19**. In the preferred embodiment of the invention the multi-directional resistance means **45** is controlled independently from the control of the endless belt **19**. The multi-directional resistance means **45** consists of a first flywheel **13** and a second flywheel **14** (FIG. 7B) mounted at the front **21** of frame **11**. Each multi-directional resistance means **45** consists of a flywheel that further includes a magnetic brake, recoil and a one way clutch. For example, resistance is generated on the user's **23** right leg from the first flywheel **13** by the user **23** pulling their right leg backward away from the first flywheel **13** using the front right leg connection means **46a**. At the same time as the user's **23** right leg moves away from the first flywheel **13** their right leg moves toward the top right rear pulley **34**, wherein the recoil of the first flywheel **13** coils the rear right leg connection means **50a**. In the next move, as the user **23** pulls their right leg away from the top right rear pulley **34** the resistance from the first flywheel **13** is applied to the user's **23** right leg using the rear right leg connection means **50a**. At the same time as the user's **23** right leg moves

away from the first flywheel **13** their right leg moves back toward the top right rear pulley **34**, wherein the recoil of the first flywheel **13** coils the front right leg connection means **46a**. Furthermore, the user's **23** left leg has resistance generated from the second flywheel **14** (FIG. 7B) and a top left rear pulley **34a** (FIG. 7B) similar to the resistance that is generated for the user's right leg.

The magnetic brake is an electric particle magnet but is substitutable by one that is a hybrid with hysteresis and eddy flow. The magnetorheological device combines a rotary brake with a flywheel thereby providing resistance and rotational inertia. A rotor rotates around a stationary member of the rotary brake and supports the generation of a magnetic field. The resistance to rotation is generated and controlled by applying a magnetic field to a pole and a medium disposed between the rotor and stationary member. The amount of resistance from the resistance means **45** is varied by the controlling means **15** through the appropriate electrical circuits. As an alternative, the resistance means **45** is comprised of four flywheels as is apparatus **10** in FIG. 1.

The first flywheel **13** is connected to user **23** by the front right leg connection means **46a** and a right third element **36** routed to the rear **20** and front **21**. On the right side of the treadmill platform **17**, the right third element **36** is guided by a right set of pulleys including the top right rear pulley **34**, the bottom right rear pulley **35** and the bottom right front pulley **37**. The front right leg connection means **46a** includes connecting to the front of the right leg strap **31a** and knee strap **30a**, a right leg first element **28a** and a right leg first rotatable structure **29a**. The first flywheel **13** is also connected to the user **23** using the rear right leg connection means **50a** at the rear of the right leg strap **31a** and knee strap **30a**. The rear right leg connection means **50a** includes connection to the rear of the right leg strap **31a** and the knee strap **30a**, a right leg second element **49a** and a right leg second rotatable structure **48a**. The second flywheel **14** (FIG. 7B) is connected to the user **23a** at the rear of the left leg by a rear left leg connection means **50b** and at the front of the left leg by a front left leg connection means **46b** as shown in FIG. 4. The rear left leg connection means **50b** is connected to the second flywheel **14** and user **23** by a left knee strap **30b**, a left leg strap **31b**, a left leg second element **49b** and a left leg rotatable structure **48b**. The second flywheel **14** is connected to the left leg of user **23a** by the left third element **36a** (FIG. 7B) that is guided by a left side set of pulleys. The left set of pulleys are mounted in a similar fashion like the right side set of pulleys including the top left rear pulley **34a** (FIG. 7B).

The frame **11** of apparatus **10a** is typically constructed of heavy gauge anodized aluminum. Other materials include, but are not limited to, mild steel, stainless steel, plastic and the like. Inside the treadmill platform **17** is mounted the treadmill variable speed motor/drive **47** and the required electrical circuitry including a transformer and inverter to convert 110 volts AC to 110 volts DC and to 12 volts DC that operates the control means **15**. The potentiometer, or as an alternative the variable DC drive, is also located inside the treadmill platform **17**.

The endless belt **19** is attached to the sides of the platform **17** by means of take up bearing assemblies. The take up bearings are used to tension the endless belt of the treadmill **10a**. In the ice skating treadmill a deck of infused wood on a shock absorbing base is mounted along the length and inside of the platform **17**. This provides a flat smooth bed that supports the entire endless belt **19** surface. The deck of infused wood is required because the width of the ice skating treadmill is typically about eight feet. Finally, the controlling means **15** panel is mounted to the frame **11** by a mounting structure **16**.

In the apparatus **10a** of FIG. 2, the multi-directional resistance means **45** is adjustable providing increased or decreased resistance to the users' leg muscles. First, the force (lbs.) of resistance or torque is adjustable in small increments by a switch, typically by a push of a button, located in the panel of the control means **15**. The force of resistance is controlled by a constant force of resistance with no relationship to the speed or incline of the endless belt **19**. Alternately, the force of resistance is controlled by a constant speed setting of the endless belt **19** with the force of resistance automatically adjusting to maintain a top maximum speed. However, the maximum speed may be set independently from the endless belt. A gauge that is located in the panel of the control means **15** will be able to record the force of resistance which the user is operating when the machine is in any mode of resistance.

The controlling means **15** includes the electrical, safety and operational controls of apparatus **10a**, including, but not limited to, the necessary relays and resistors for system operation. The controlling means **15** includes a panel that incorporates main power switches, an emergency stop switch, a digital speed indicator, a heart rate monitor and the like. For example, the controlling means **15** houses the inverter to convert from AC to DC and the electronic circuitry to control the endless belt **19** in the forward movement and the backward movement when the treadmill **10a** is an ice skating treadmill. The forward and backward movement is operated by a switch mounted on the controlling means **15** panel. Resistance control in the form of a rotary switch or similar means, for each flywheel, are individually mounted on the controlling means **15** panel. As an alternative, one rotary switch or similar means provides the resistance control for all the flywheels. Further features include right and left endless belt **19** fault indicator lamps to indicate when the endless belt over tracks to one side. A drive fault indicator lamp is included to signal a drive problem. Also, a belt start/stop switch is used to activate the running belt while a rotary switch is used to select the desired speed of the belt. As is known by the practitioner in the art the rotary switches are replaceable by a digital system. Finally, the controlling means **15** allows the user **23** to regulate the resistance means **45** and the endless belt **19** speed to change the effect of the users' workout including raising and lowering the incline of the endless belt.

FIG. 3 shows a detailed view of the user's **23** right leg with the front right leg connection means **46a** and the rear right leg connection means **50a** in the preferred embodiment of the invention. The right leg of user **23** by means of the right knee strap **30a** and the right leg strap **31a** is connected to the first and the third flywheels or the first flywheel and the top right rear pulley. Alternately, the flywheel arrangement is substitutable for a hydraulic mechanism and would use the same right knee and leg strap. The front right leg connection means **46a** consists of a right leg first element **28a** that is connected by a right leg first rotatable structure **29a**, which in turn connects to a right leg first segment **40a** and a right leg second segment **39a**. The right leg second segment **39a** is connected to the right leg strap **31a** in the front and the right leg first segment **40a** is connected to the right knee strap **30a** in the front. The right leg first element **28a** is connected to a flywheel or hydraulic mechanism. The rear right leg connection means **50a** consists of a right leg second element **49a** connected to a flywheel or hydraulic mechanism and a right leg second rotatable structure **48a**, which in turn connects to a right leg third segment **41a** and a right leg fourth segment **42a**. The third segment **41a** is connected to the right knee strap **30a** in the back and the

fourth segment **42a** is connected to the right leg strap **31a** in the back. The left leg of user **23** is connected in a similar fashion like the right leg with a front left leg connection means **46b** and a rear left leg connection means **50b** (FIG. 4). The elements and segments are comprised of different items of construction including, but not limited to, rope, wire rope, wire, cable and stranded cable.

A detailed view of the user's **23** left leg with the front left leg connection means **46b** and the rear left leg connection means **50b** is shown in FIG. 4. The left leg of user **23** is connected to the second and fourth flywheel or to the second flywheel and top left rear pulley arrangement. Alternately, the flywheel arrangement is substitutable for a hydraulic mechanism arrangement (FIG. 6) that would use the same left knee and leg strap as the flywheel arrangement. The front left leg connection means **46b** consists of a first element **28b** that is connected by a first rotatable structure **29b**, which in turn connects to a first segment **40b** and a second segment **39b**. The second segment **39b** is connected to the right leg strap **31b** at the front and the first segment **40b** is connected to the left knee strap **30b** at the front. The first element **28b** is connected to either a flywheel or hydraulic mechanism. The rear left leg connection means **50b** consists of a second element **49b** connected to either a flywheel or hydraulic mechanism and a second rotatable structure **48b**, which in turn connects to a third segment **41b** and a fourth segment **42b**. The third segment **41b** is connected to the left knee strap **30b** at the back and the fourth segment **42b** is connected to the left leg strap **31b** at the back. The right leg of user **23** is connected in a similar fashion like the left leg with a front right leg connection means **46a** and a rear right leg connection means **50a** (FIG. 3). The elements and segments are comprised of different items of construction including, but not limited to, rope, wire rope, wire, cable and stranded cable.

FIG. 5 illustrates treadmill apparatus **10b** in the preferred embodiment of the invention. The apparatus **10b** includes a multi-directional resistance means **45** that consists of two hydraulic mechanisms using fluid in a hydraulic circuit with a reservoir **55** and an adjustable orifice control valve **13e** (FIG. 6A) to create and adjust the amount of the resistance. The hydraulic reservoir **55** is mounted toward the rear **20** of apparatus **10b**. The switch for the adjustable orifice control valve **13e** is located in the panel of the controlling means **15** mounted on the mounting structure **16**. The first hydraulic mechanism **13a** is mounted on frame **11a** at the front **21**. The second hydraulic mechanism **14a** (FIG. 7C) is mounted on frame **11a** at the front **21**. As an option the first hydraulic mechanism **13a** and the second hydraulic mechanism **14a** may be mounted at the rear **20** of frame **11**. In an event, the height of these two hydraulic mechanisms will be adjustable as will their rotation position relative to the user **23**. Alternately, four hydraulic mechanisms **13a**, **14a**, **12a** and **18a** are used as the multi-directional resistance means **45** as shown in FIG. 7C. The hydraulic mechanisms are positioned on the frame **11**, similarly as to the location of the flywheel arrangements, and include a one-way clutch and recoil mechanism. For example, a four hydraulic mechanism treadmill will have two hydraulic mechanisms, **13a** and **14a**, mounted on the front **21** of the treadmill apparatus **10b**. The other two hydraulic mechanisms, **12a** and **18a**, are mounted at the rear **20** of treadmill apparatus **10b**. The hydraulic circuitry and reservoir **55** will be located inside the treadmill platform **17a**. All hydraulic mechanisms will be connected to the same hydraulic reservoir **55**. Finally, the multi-directional resistance means **45** will provide one-way resistance and then recoil back with the opposite resistance on the

other half of the users' **23** stride. This will strengthen their leg muscles and duplicate athletic procedures as the user **23** holds the front bar **33** of the treadmill apparatus **10b**.

The apparatus **10b** contains an endless belt **19** that has a variable speed from about zero to 28 mph. The endless belt **19** is adjustable in height allowing the endless belt to incline relative to the treadmill platform **17a**. This provides the user **23** with the simulation of the resistance of exercising up a hill. The treadmill **10b** contains a motor/drive **47** arrangement mounted inside the treadmill platform **17a** as is typical in the art. Furthermore, a servo-motor is used to adjust the elevation of the endless belt **19**. The user **23** regulates the speed and elevation of the endless belt **19** from the controlling means **15** panel. The speed control for the treadmill apparatus **10b** typically is accomplished by use of a potentiometer as is known by the practitioner in the art. However, the treadmill **10b** speed is also controllable by the use of a variable speed DC motor and hardware in other applications. This includes an AC to DC inverter so that the treadmill is conveniently plugged into any home 110 VAC outlet.

The first hydraulic mechanism **13a** is connected to the front right leg by the front right leg connection means **46a**, the rear right leg by the rear right leg connection means **50a** and mounted to the frame **11a** by a first base **25**. Similarly, the second hydraulic mechanism **14a** is connected to the left leg by the front left leg connection means **46b**, the rear left by the left leg connection means **50b** and mounted to the frame **11a** by a second base **25a** (FIG. 7C). This allows the user **23** to increase the strength of their lower extremities and stride when using the treadmill apparatus **10b**.

The multi-directional resistance means **45** works in conjunction with the endless belt **19** or independent of the endless belt **19** through the controlling means **15**. In the preferred embodiment of the invention the multi-directional resistance means **45** is independently operated from the operation of the endless belt **19**. The multi-directional resistance means **45** consists of a first hydraulic mechanism **13a** and a second hydraulic mechanism **14a** (FIG. 7C) mounted at the front **21** of frame **11**. In another embodiment the first and second hydraulic mechanism can be mounted in the rear **20** of frame **11**. Each multi-directional resistance means **45** consists of a hydraulic mechanism, a spool with a recoil spring and a one-way clutch. For example, resistance is generated on the user's **23** right leg from the first hydraulic mechanism **13a** by the user **23** pulling their right leg backward away from the first hydraulic mechanism **13a** using the front right leg connection means **46a**. At the same time as the user's **23** right leg moves away from the first hydraulic mechanism **13a** their right leg moves toward the top right rear pulley **34**, wherein the recoil of the first hydraulic mechanism **13a** coils the rear right leg connection means **50a**. In the next move, as the user **23** pulls their right leg away from the top right rear pulley **34** the resistance from the first hydraulic mechanism **13a** is applied to the user's **23** right leg using the rear right leg connection means **50a**. At the same time as the user's **23** right leg moves away from the first hydraulic mechanism **13a** their right leg moves back toward the top right rear pulley **34**, wherein the recoil of first hydraulic mechanism **13** coils the front right leg connection means **46a**. Furthermore, the user's **23** left leg has resistance generated from the second hydraulic mechanism **14a** (FIG. 7C) and a top left rear pulley **34a** (FIG. 7C) similar to the resistance generated for the user's right leg. As another alternative, the resistance means **45** is comprised of four hydraulic mechanisms as is apparatus **10c** (FIG. 7C).

The first hydraulic mechanism **13a**, as shown in FIG. 5A, is connected to user **23** by the front right leg connection

13

means **46a**, a rear right leg connection means **50a** and a right third element **36** routed to the rear **20** and front **21**. The first hydraulic mechanism **13a** provides directed resistance through the first sprocket **24** in communication with the front right leg connection means **46a** and the right third element **36**. The right third element **36** is guided by a right set of pulleys including the top right rear pulley **34**, the bottom right rear pulley **35**, the bottom right front pulley **37** and the top right front pulley **38** on the right side of the treadmill apparatus **10b**. The second hydraulic mechanism **14a**, as shown in FIG. 5B, is connected to the user **23** to the rear of the left leg by a rear left leg connection means **50b** and to the front of the left leg by a front left leg connection means **46b**. The second hydraulic mechanism **14a** provides directed resistance through the second sprocket **24a** in communication with the front left leg connection means **46b** and the left third element **36a**. The second hydraulic mechanism **14a** is connected to the left leg of user **23** by the left third element **36a** guided by a left side set of pulleys. This includes the top left rear pulley **34a**, the bottom left rear pulley **35a**, the bottom left front pulley **38** and the top left front pulley **38a** on the left side of the treadmill apparatus **10b**.

The frame **11a** of apparatus **10b** is typically constructed of heavy gauge anodized aluminum. Other materials include, but are not limited to, mild steel, stainless steel, plastic and the like. Inside the treadmill platform **17a** is mounted the variable speed motor/drive **47** and the required electrical circuitry including a transformer and inverter to convert 110 volts AC to 110 volts DC and 12 volts DC to operate the control means **15**. The potentiometer, or as an alternative the variable DC drive, is also located inside the treadmill platform **17a**. The endless belt **19** is attached to the sides of the platform **17a** by means of take up bearing assemblies. The take up bearings are used to tension the endless belt of the treadmill **10b**. In the ice skating treadmill there are three to five rows of support rollers that are mounted along the length and inside of the platform **17a** to provide support for the entire endless belt **19** surface. They are staggered to give the endless belt a flat smooth bed on which to run. This is because the endless belt **19** in an ice skating treadmill is typically about eight feet in width. In the running treadmill the endless belt **19** is supported by a smooth platform positioned underneath the belt and this gives the endless belt a flat smooth bed on which to run. Finally, the controlling means **15** panel is mounted to the frame **11a** by a mounting structure **16**.

In the apparatus **10b** of FIG. 5, the multi-directional resistance means **45** is adjustable providing increased or decreased resistance to the users' leg muscles. First, the force (lbs.) of resistance or torque is adjustable in small increments by a switch, typically by a push of a button, located in the panel of the control means **15**. The force of resistance is controlled by a constant force of resistance with no relationship to the speed or incline of the endless belt **19**. Alternately, the force of resistance is controlled by a constant speed setting of the endless **19** with the force of resistance automatically adjusting to maintain an optimum speed. A gauge positioned in the panel of the control means **15** will be able to record the force of resistance which the user is operating when the machine is in any speed mode of resistance.

The controlling means **15** includes the electrical, safety and operational controls of the treadmill apparatus **10b**, including, but not limited to, the necessary relays and resistors for system operation. The controlling means **15** includes a panel that incorporates main power switches, an

14

emergency stop switch, a digital speed indicator, a heart rate monitor and the like. For example, the controlling means **15** houses the inverter to convert from AC to DC and the electronic circuitry to control the endless belt **19** in the forward movement and the backward movement when the treadmill **10b** is an ice skating treadmill. The forward and backward movement is operated by a switch mounted on the controlling means **15** panel. Resistance control in the form of a rotary switch or similar means, for each flywheel, are individually mounted on the controlling means **15** panel. As an alternative, one rotary switch or similar means provides the resistance control for all the flywheels. Further features include right and left endless belt **19** fault indicator lamps to indicate when the endless belt over tracks to one side. A drive fault indicator lamp is included to signal a drive problem. Also, a belt start/stop switch is used to activate the running belt while a rotary switch is used to select the desired speed of the belt. As is known by the practitioner in the art the rotary switches are replaceable by a digital system. Finally, in the controlling means **15** the force of resistance is controlled by a constant force of resistance with no relationship to the speed or incline of the endless belt **19**. Alternately, the force of resistance is controlled by a constant speed setting of the endless belt **19** with the force of resistance automatically adjusting to maintain a top maximum speed. However, the maximum speed may be set independently from the endless belt. A gauge that is located in the panel of the control means **15** will be able to record the force of resistance which the user is operating when the machine is in any mode of resistance.

the user **23** to regulate the resistance means **45** and the endless belt **19** speed to change the effect of the users' workout including raising and lowering the incline of the endless belt.

FIGS. 6A, 6B, 6C and 6D illustrate the multi-directional resistance means **45** with the various hydraulic mechanisms in the preferred embodiment of the invention.

FIG. 6A shows that the first hydraulic mechanism **13a** is in communication with the first shaft **13b**. The first shaft **13b** is in communication with the first recoil spool **13c**, the first one-way clutch **13d** and the first pillow block bearing **13f**. A first adjustable orifice control **13e**, that is integral with the first hydraulic mechanism **13a**, increases or decreases the flow to and from the reservoir **55** by increasing or decreasing the opening of the orifice. Increasing or decreasing the opening of the orifice, by adjusting the adjustable orifice **13e**, will accordingly increase or decrease the amount of resistance obtained from the first hydraulic mechanism **13a**. The first hydraulic mechanism **13a** provides resistance when the front right leg connection means **46a** is being pulled out of the first recoil spool **13c** and is freewheeling (no resistance) when the first recoil spool **13c** coils the front right leg connection means **46a**. The recoil is accomplished by a spring that is part of the first recoil spool **13c** and the first one-way clutch **13d**. Alternately, the first one way clutch **13d** is substitutable for a one-way bearing. When the front right leg connection means **46a** is pulled out of the first recoil spool **13c** the first one-way clutch **13d** engages the first shaft **13b** which communicates with the first hydraulic mechanism **13a**. As the first shaft **13b** turns, it moves hydraulic fluid through the first adjustable orifice (hole) control **13e** that is integrally a part of the first hydraulic mechanism **13a** creating the resistance. The resistance is increased or decreased by adjusting the first adjustable orifice control **13e**. At the same time, the front right leg connection means **46a** is being pulled out from (away from) the first recoil spool **13c** and turning the first shaft **13b**, the

## 15

spring in the first recoil spool 13c is winding tighter. When the right leg moves into (toward) the first recoil spool 13c, the spring in the first recoil spool 13c retrieves the front right leg connection means 46a. There is no resistance when the front right leg connection means 46a is retrieved because the

first one-way clutch 13d disengages the first shaft 13b from the first hydraulic mechanism 13d, wherein the first hydraulic mechanism does not turn.

FIG. 6B shows that the second hydraulic mechanism 14a is in communication with the second shaft 14b. The second shaft 14b is in communication with the second recoil spool 14c, the second one-way clutch 14d and the second pillow block bearing 14f. A second adjustable orifice control 14e that is integral with the second hydraulic mechanism 14a increases or decreases the flow to and from the reservoir 55 by increasing or decreasing the opening of the orifice. Increasing or decreasing the opening of the orifice, by adjusting the first adjustable orifice, will accordingly increase or decrease the amount of resistance obtained from the second hydraulic mechanism 14a. The second hydraulic mechanism 14a provides resistance when the front left leg connection means 46b is being pulled out of the second recoil spool 14c and is freewheeling (no resistance) when the second recoil spool 14c coils the front left leg connection means 46b. The recoil is accomplished by a spring that is part of the second recoil spool 14c and the second one-way clutch 14d. Alternately, the second one way clutch 14d is substitutable for a one-way bearing. When the front left leg connection means 46b is pulled out of the second recoil spool 14c the second one-way clutch 14d engages the second shaft 14b which communicates with the second hydraulic mechanism 14a. As the second shaft 14b turns, it moves hydraulic fluid through the second adjustable orifice (hole) control 14e that is integrally a part of the second hydraulic mechanism 14a creating the resistance. The resistance is increased or decreased by adjusting the second adjustable orifice control 14e. At the same time, as the front left leg connection means 46b is being pulled out from (away from) the second recoil spool 14c and turning the second shaft 14b the spring in the second recoil spool 14c is winding tighter. When the left leg moves into (toward) the second recoil spool 14c the spring in the second recoil spool 14c retrieves the front left leg connection means 46b. There is no resistance when the front left leg connection means 46b is retrieved because the second one-way clutch 14d disengages the second shaft 14b from the second hydraulic mechanism 14d, wherein the second hydraulic mechanism does not turn.

FIG. 6C shows that the third hydraulic mechanism 12a is in communication with the third shaft 12b. The third shaft 12b is in communication with the third recoil spool 12c, the third one-way clutch 12d and the third pillow block bearing 12f. A third adjustable orifice control 12e, that is integral to the third hydraulic mechanism 12a, increases or decreases the flow to and from the reservoir 55 by increasing or decreasing the opening of the orifice. Increasing or decreasing the opening of the orifice, by adjusting the third adjustable orifice 12e, will accordingly increase or decrease the amount of resistance obtained from the third hydraulic mechanism 12a. The third hydraulic mechanism 12a provides resistance when the rear right leg connection means 50a is being pulled out of the third recoil spool 12c and is freewheeling (no resistance) when the third recoil spool 12c coils the rear right leg connection means 50a. The recoil is accomplished by a spring that is part of the third recoil spool 12c and the third one-way clutch 12d: Alternately, the third one way clutch 12d is substitutable for a one-way bearing.

## 16

When the rear right leg connection means 50a is pulled out of the third recoil spool 12c the third one-way clutch 12d engages the third shaft 12b, which communicates with the third hydraulic mechanism 12a. As the third shaft 12b turns it moves hydraulic fluid through the third adjustable orifice (hole) control 12e that is integrally a part of the third hydraulic mechanism 12a creating the resistance. The resistance is increased or decreased by adjusting the third adjustable orifice control 12e. At the same time, as the rear right leg connection means 50a is being pulled out from (away from) the third recoil spool 12c and turning the third shaft 12b the spring in the third recoil spool 12c is winding tighter. When the right leg moves into (toward) the third recoil spool 12c the spring in the third recoil spool 12c retrieves the rear right leg connection means 50a. There is no resistance when the rear right leg connection means 50a is retrieved because the third one-way clutch 12d disengages the third shaft 12b from the third hydraulic mechanism 12d, wherein the third hydraulic mechanism does not turn.

FIG. 6D shows that the fourth hydraulic mechanism 18a is in communication with the fourth shaft 18b. The fourth shaft 18b is in communication with the fourth recoil spool 18c, the fourth one-way clutch 18d and the fourth pillow block bearing 18f. A fourth adjustable orifice control 18e, that is integral to the fourth hydraulic mechanism 18a, increases or decreases the flow to and from the reservoir 55 by increasing or decreasing the opening of the orifice. Increasing or decreasing the opening of the orifice, by adjusting the fourth adjustable orifice 14e, will accordingly increase or decrease the amount of resistance obtained from the fourth hydraulic mechanism 18a. The fourth hydraulic mechanism 18a provides resistance when the rear left leg connection means 50b is being pulled out of the fourth recoil spool 18c and is freewheeling (no resistance) when the fourth recoil spool 18c coils the rear left leg connection means 50b. The recoil is accomplished by a spring that is part of the fourth recoil spool 18c and the fourth one-way clutch 18d. Alternately, the fourth one way clutch 18d is substitutable for a one-way bearing. When the rear left leg connection means 50b is pulled out of the fourth recoil spool 18c the fourth one-way clutch 18d engages the fourth shaft 18b which communicates with the fourth hydraulic mechanism 18a. As the fourth shaft 18b turns, it moves hydraulic fluid through the fourth adjustable orifice (hole) control 18e that is integrally a part of the fourth hydraulic mechanism 18a creating the resistance. The resistance is increased or decreased by adjusting the fourth adjustable orifice control 18e. At the same time, as the rear left leg connection means 50b is being pulled out from (away from) the fourth recoil spool 18c and turning the fourth shaft 18b the spring in the fourth recoil spool 18c is winding tighter. When the left leg moves into (toward) the fourth recoil spool 18c the spring in the fourth recoil spool 18c retrieves the rear left leg connection means 50b. There is no resistance when the rear left leg connection means 50b is retrieved because the fourth one-way clutch 18d disengages the fourth shaft 18b from the fourth hydraulic mechanism 18d, wherein the fourth hydraulic mechanism does not turn.

The amount and kind of resistance produced from the first, second, third and fourth hydraulic mechanisms will be the result of the controlling means 15 adjusting and regulating the adjustable orifice control for each hydraulic mechanism. The controlling means 15 will allow the treadmill apparatus 10c (FIG. 7C) to remotely control the hydraulic mechanisms switching them between isokinetic resistance and isotonic resistance (constant force or maximum speed). As is known by the practitioner in the art, the

17

appropriate electronic circuitry will be located in the panel of the controlling means 15 to adjust and regulate the various adjustable orifice controls in each hydraulic mechanism.

FIG. 7A shows the top view of treadmill apparatus 10 in the preferred embodiment of the invention using a four flywheel arrangement. The multi-directional resistance means 45 consists of the first flywheel 13 and the second flywheel 14 arrangement that is mounted at the front 21 of the treadmill platform 17 of the apparatus 10. The controlling means 15 panel is mounted at the front 21 of the apparatus 10. A user will operate the apparatus 10 engaging and adjusting the speed of the endless belt 19 from the controlling means 15 panel. There is a mechanism to disengage the endless belt 19 from its motor/drive arrangement 47 to allow the endless belt to move freely without the resistance caused by the motor/drive arrangement. The user will hold onto the front bar 33 and duplicate athletic procedures with the left side bar 32 and the right side bar 22. As a safety feature, the user can be strapped into a harness secured to a harness frame connected to the treadmill platform 17 when the speed of the endless belt 19 is fast. The multi-directional resistance means 45 further consists of a third flywheel 12 and the fourth flywheel 18 arrangement that is mounted at the rear 20 of the treadmill platform 17 of the apparatus 10. The front right leg connection means 46a communicates with the first flywheel 13 and the front left leg connection means 46b communicates with the second flywheel 14. Finally, the rear right leg connection means 50a communicates with the third flywheel 12 and the rear left leg connection means 50b communicates with the fourth flywheel 18.

FIG. 7B shows the top view of treadmill apparatus 10a in the preferred embodiment of the invention using a two flywheel arrangement. The multi-directional resistance means 45a consists of the first flywheel 13 and the right flywheel 14 arrangement that is mounted at the front 21 of the treadmill platform 17 of the apparatus 10a. Alternately, the first and second flywheel can be mounted in the rear 20 of the treadmill apparatus 10a. The controlling means 15 panel is mounted at the front 21 of the apparatus 10a. A user will operate the apparatus 10a engaging and adjusting the speed of the endless belt 19 from this panel. There is a mechanism to disengage the endless belt 19 from its motor/drive arrangement 47 to allow the endless belt to move freely without the resistance caused by the motor/drive arrangement. The user will hold onto the front bar 33 and duplicate athletic procedures with the left side bar 32 and the right side bar 22. As a safety feature, the user can be strapped into a harness secured to a harness frame connected to the treadmill platform 17 when the speed of the endless belt 19 is fast. The user is connected to the right flywheel 13a arrangement by the front right leg connection means 46a, the rear right leg connection means 50a and a right third element 36. The right third element 36 is guided by a set of right pulleys including the top right rear pulley 34, the bottom right rear pulley 35 and the bottom right front pulley 37. Similarly, the user is connected to the left flywheel 14a arrangement by the front left leg connection means 46b, the rear left leg connection means 50b and a left third element 36a. The left third elements 36a is guided by a set of left pulleys including the top left rear pulley 34a, the bottom left front pulley 37a and the bottom left rear pulley 35a.

FIG. 7C shows the top view of the treadmill apparatus 10c in the preferred embodiment of the invention using a four hydraulic mechanism arrangement. The multi-directional resistance means 45 consists of the first hydraulic mechanism 13a and the second hydraulic mechanism 14a arrange-

18

ment that are mounted at the front 21 of the treadmill platform 17a of the apparatus 10c. The third hydraulic mechanism 12a and the fourth hydraulic mechanism 18a arrangement are mounted at the rear 20 of the treadmill platform 17a of the apparatus 10c. The hydraulic reservoir 55 is mounted in the treadmill platform 17a toward the rear 20. The controlling means 15 panel is mounted at the front 21 of the apparatus 10c. A user will operate the apparatus 10c engaging and adjusting the speed of the endless belt 19 from this panel. There is a mechanism to disengage the endless belt 19 from its motor/drive arrangement 47 to allow the endless belt to move freely without the resistance caused by the motor/drive arrangement. The user will hold onto the front bar 33 and duplicate athletic procedures with the left side bar 32a and the right side bar 22a. As a safety feature, the user can be strapped into a harness secured to a harness frame connected to the treadmill platform 17a when the speed of the endless belt 19 is fast. The front right leg connection means 46a communicates with the first hydraulic mechanism 13a and the front left leg connection means 46b communicates with the second hydraulic mechanism 14a. Finally, the rear right leg connection means 50a communicates with the third hydraulic mechanism 12a and the rear left leg connection means 50b communicates with the fourth hydraulic mechanism 18a.

FIG. 8 shows the top view of the stationary apparatus 10d which is the stationary platform 17b arrangement of the preferred embodiment of the invention. This stationary apparatus 10d is used to simulate ice skating procedures. The multi-directional resistance means 45 consists of the first hydraulic mechanism 13a and the second hydraulic mechanism 14a arrangement that are mounted at the front 21 of the stationary platform 17b of the stationary apparatus 10d. The controlling means 15 panel is mounted at the front 21 of the apparatus 10d. The user will hold onto the front bar 33 and duplicate athletic procedures with the left side bar 32b and the right side bar 22b. The third hydraulic mechanism 12a and the fourth hydraulic mechanism 18a arrangement are mounted at the rear 20 of the stationary platform 17b of the apparatus 10d. The hydraulic reservoir 55 is mounted in the stationary platform 17b toward the rear 20.

The stationary platform 17b is typically about eight feet wide so that a user has the ability to duplicate actual ice skating procedures. To accomplish this, the cover 19a is positioned on top of the stationary platform 17b and typically is constructed of UHMW polyethylene material. However, other material is substitutable for the UHMW polyethylene, including but not limited to, any high density plastic material that is flexibly strong and in combination with the ice skates 80 provides a coefficient of friction similar to that of ice. Alternately, the eight feet of width of the stationary platform 17b and cover 19a is substitutable for smaller or larger size that will allow an athlete to duplicate the desired ice skating procedures. In any event, the apparatus 10d is used with ice skates 80 as shown in FIG. 9. The ice skates 80 include the boots 81 and the polytetrafluoroethylene 83 covering of the blades 82. The use of the ice skates 80 along with the cover 19a provides a low coefficient of friction that allows the user of apparatus 10d to duplicate ice skating procedures.

While there has been illustrated and described what is at present considered to be the preferred embodiment of the invention, it should be appreciated that numerous changes and modifications are likely to occur to those skilled in the art. It is intended in the appended claims to cover all those changes and modifications that fall within the spirit and scope of the present invention.

What is claimed is:

1. An exercise apparatus comprising:
  - a frame for supporting all the components of said apparatus;
  - a multi-directional resistance means for providing a user of said apparatus the ability to duplicate actual athletic procedures;
  - a treadmill for said user to operate in conjunction with said multi-directional resistance means;
  - a connection means between at least two legs of said user and said multi-directional resistance means;
  - a front bar for said user to hold onto while strengthening said users' stride; and
  - a controlling means for adjusting said multi-directional resistance means, wherein the adjusting changes the effect of the users' workout.
2. The apparatus as claimed in claim 1, wherein said frame further includes a first sidebar and a second sidebar.
3. The apparatus as claimed in claim 1, wherein said multi-directional resistance means further comprises at least two flywheels each with a magnetic brake, a recoil and a one way clutch.
4. The apparatus as claimed in claim 3, wherein said magnetic brake is selected from the group consisting of an electric particle magnet and a hybrid with a hysteresis eddy flow.
5. The apparatus as claimed in claim 1, wherein said treadmill further consists of a motor providing a speed from stop to about 28 mph.
6. The apparatus as claimed in claim 1, wherein said treadmill further consists of an endless belt constructed of UHMW polyethylene material, a forward movement, a backward movement and an adjustable motor providing a variable speed.
7. The apparatus as claimed in claim 1, wherein said connection means further consists of an element, a rotatable structure and two segments with one connecting to a knee strap and the other connecting to a leg strap.
8. The apparatus as claimed in claim 1, wherein said multi-directional resistance means further consists of a first flywheel and a second flywheel mounted at the front of said frame.
9. The apparatus as claimed in claim 1, wherein said multi-directional resistance means further consist of a first and second flywheel mounted at the front of said frame and a third and fourth flywheel mounted at the rear of said frame.
10. The apparatus as claimed in claim 8, wherein said first flywheel is connected to the front of the right leg of said user by said connection means and said second flywheel is connected to the front of the left leg of said user by said connections means.
11. The apparatus as claimed in claim 9, wherein said first flywheel is connected at the front leg of said user by said connection means, said second flywheel is connected at the front of the left leg of said user by said connection means, said third flywheel is connected at the rear of the right leg of said user by said connection means and said fourth flywheel is connected at the rear of the left leg of said user by said connection means.
12. The apparatus as claimed in claim 8, wherein said first flywheel further consists of a right set of pulleys mounted underneath and to the rear of said frame allowing an element

- to be routed and connected by said connection means to the back side of the users right leg.
- 13. The apparatus as claimed in claim 8, wherein said second flywheel further consists of a left set of pulleys mounted underneath and to the rear of said frame allowing an element to be routed and connected by said connection means to the back side of the users left leg.
- 14. The apparatus as claimed in claim 1, wherein said multi-directional resistance means further consists of at least two hydraulic mechanisms with a recoil and a one way clutch.
- 15. The apparatus as claimed in claim 14, wherein said hydraulic mechanism further consists of hydraulic fluid, a reservoir, an adjustable orifice control, a one-way clutch, a recoil spool, a shaft and a pillow block bearing.
- 16. The apparatus as claimed in claim 1, wherein the rotation position of said hydraulic mechanism is adjustable.
- 17. The apparatus as claimed in claim 1, wherein said treadmill is substitutable for an ice skating stationary deck further comprising a UHMW cover.
- 18. The apparatus as claimed in claim 17, wherein said stationary deck further comprises a surface constructed of UHMW polyethylene material.
- 19. The apparatus as claimed in claim 18, wherein said UHMW polyethylene is substitutable for a plurality of materials.
- 20. The apparatus as claimed in claim 1, wherein said multi-directional resistance means further comprises a first and second hydraulic mechanism each with a recoil and one way clutch mounted on the front of said frame.
- 21. The apparatus as claimed in claim 1, wherein said multi-directional resistance means further consist of a first and second hydraulic mechanism mounted at the front of said frame and a third and fourth hydraulic mechanism mounted at the rear of said frame.
- 22. The apparatus as claimed in claim 15, wherein said one-way clutch is substitutable for a one-way bearing.
- 23. The apparatus as claimed in claim 20, wherein said first hydraulic mechanism further consists of a right set of pulleys mounted underneath to the rear and the front and mounted on top to the rear and the front of said frame.
- 24. The apparatus as claimed in claim 20, wherein said second hydraulic mechanism further consists of a left set of pulleys mounted underneath to the rear and the front and mounted on top to the rear and the front of said frame.
- 25. The apparatus as claimed in claim 1, wherein said multi-directional resistance means further consists of a first flywheel and a second flywheel mounted at the rear of said frame.
- 26. The apparatus as claimed in claim 1, wherein said multi-directional resistance means further comprises a first and second hydraulic mechanism each with a recoil and one way clutch mounted on the rear of said frame.
- 27. The apparatus as claimed in claim 1, wherein said apparatus further consists of a harness supported by a frame.
- 28. The apparatus as claimed in claim 1, wherein said treadmill is used in combination with skating boots with polytetrafluoroethylene coated rails.
- 29. The apparatus as claimed in claim 17, wherein said stationary deck is used in combination with skating boots with polytetrafluoroethylene coated rails.