

EE241 Semester Project – Spring 2003

Circuits for Low Power Bus Encoding

Yatish Patel, Yury Markovskiy
with Victor Wen



Outline

- Problem
- Previous Work
- Our Implementation
- Simulations and Analysis
- *Impressive* Layout Picture
- Oh Crap (Conclusion)



Problem

- As technology scales down the percentage of chip power attributed to just wires increases.
- How can we decrease the amount of energy needed to simply transfer 32 bits of information across a bus from point A to point B on the die?

Previous Work

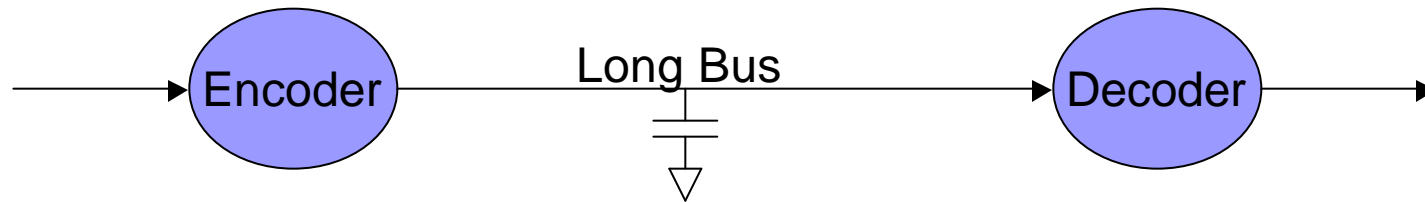

- All methods target off-chip buses with large capacitance ($>10\text{pf}$) so the encoder/decoder circuit power is negligible
 - Bus-Invert Coding [Stan95]
 - Low power bus coding [Sotiriadis00]
 - Adaptive address bus coding [Henkel01]
- On-chip wire for Metal 3 is $.08\text{pF/mm}$

Energy Budget

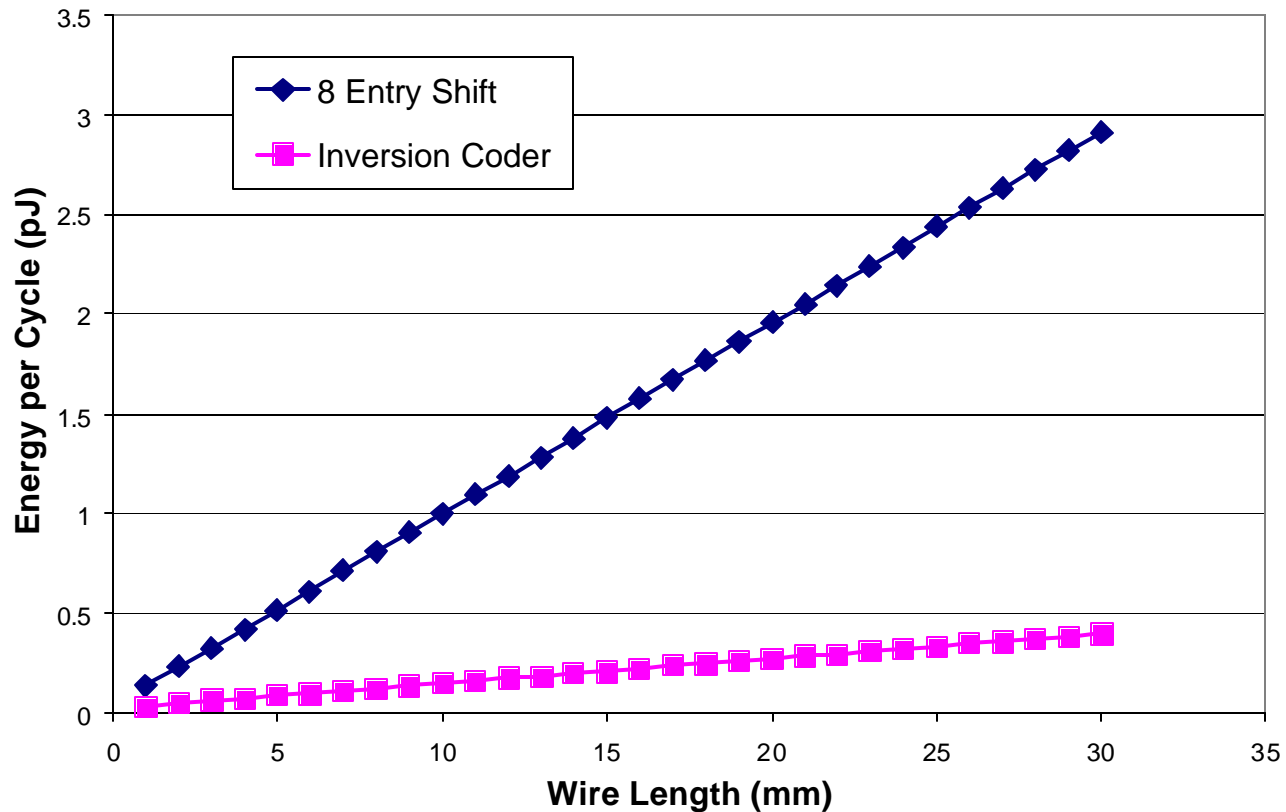

- Average savings from register bus traces of SPEC95 benchmarks runs

Block Diagram of Circuit

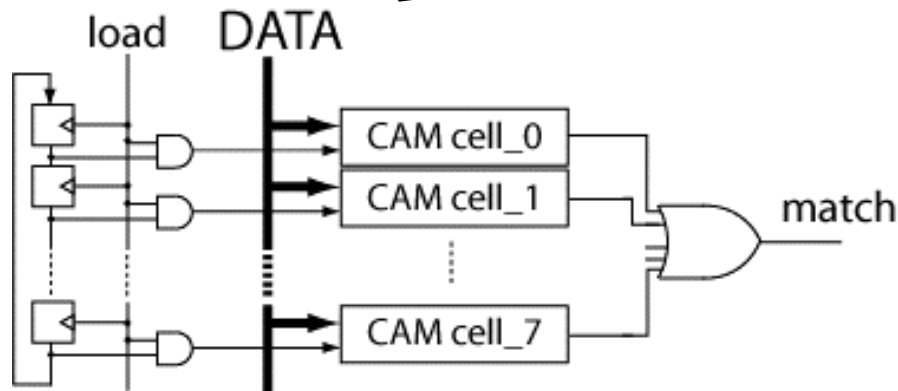
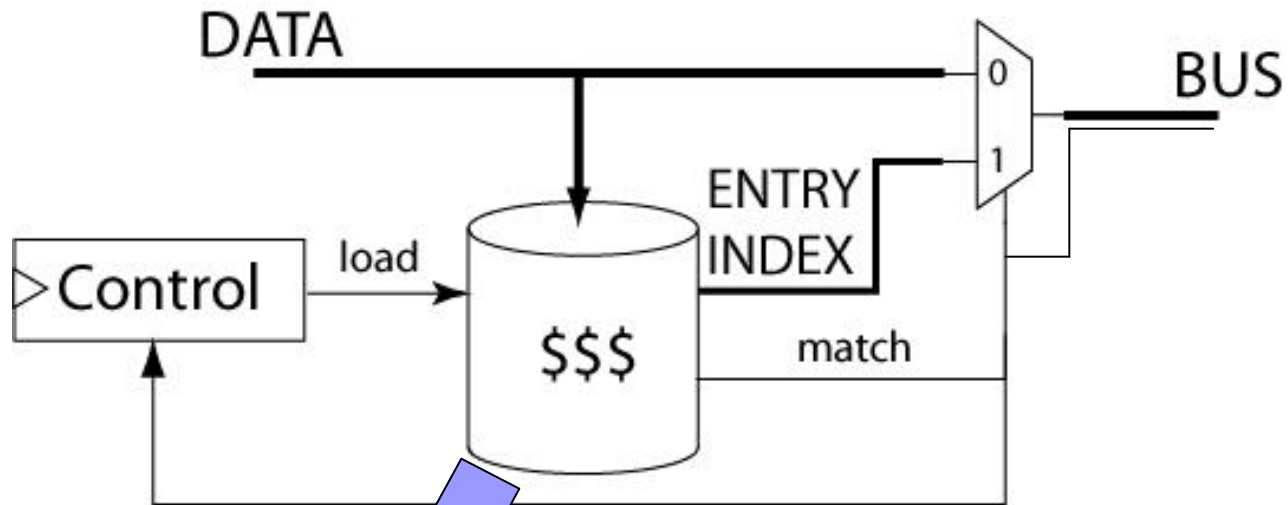

- Caches 8 bus values
- On cache hit we send the entry index rather than the actual data value



Simulations and Analysis

- STMicro .13 μ custom layout
- Level 3 extraction to generate a netlist from the layout
 - Lump capacitors and no resistors
 - Level 3 uses more energy than more accurate Level 1 extraction (distributed RC)
- Modified the netlist to output energy consumption for separate circuit blocks
- Ran a 50 cycle trace using SPICE to compare circuits

■ Shift
 ■ Control
 ■ InputBuf
 ■ MatchTree
 ■ Match

CAM Cell Redesign

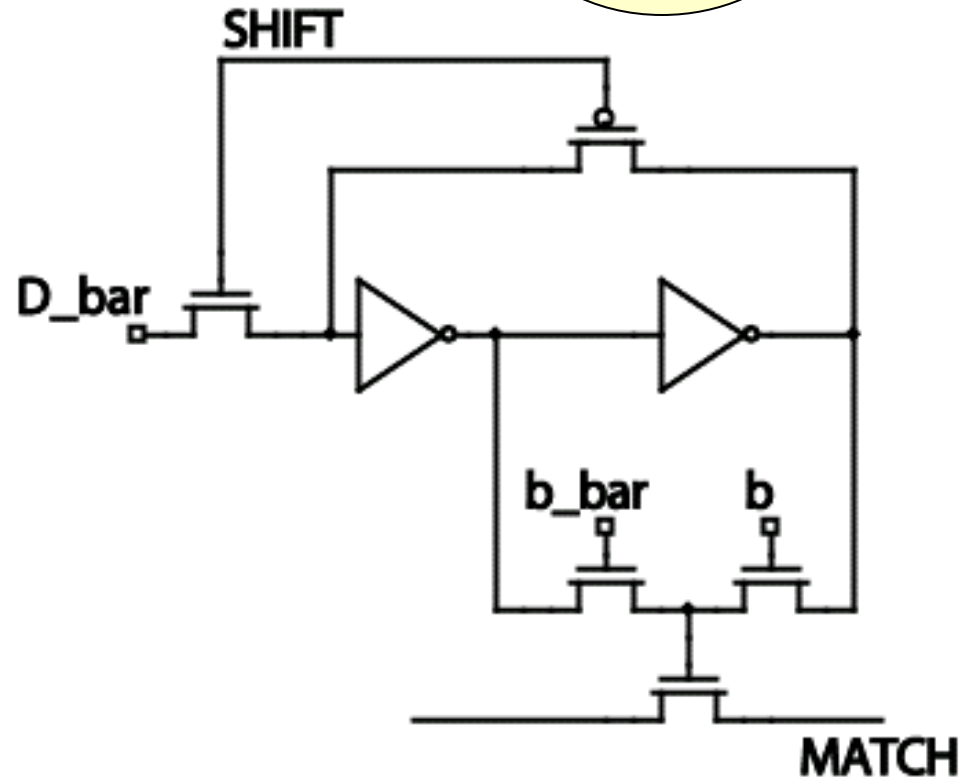
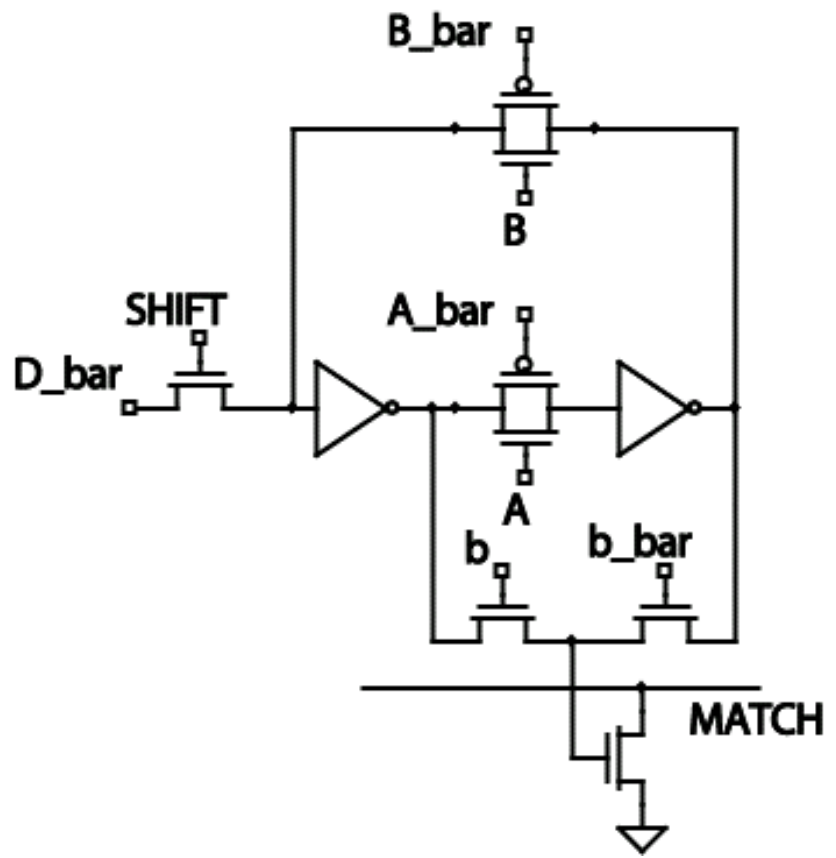
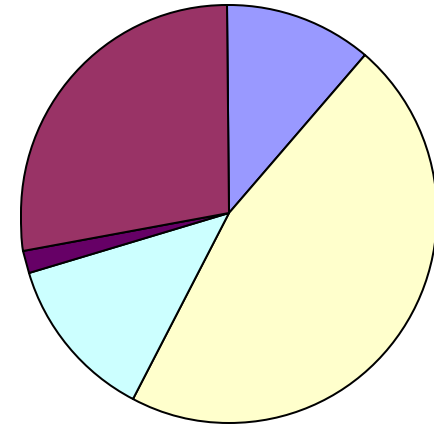

Match Redesign

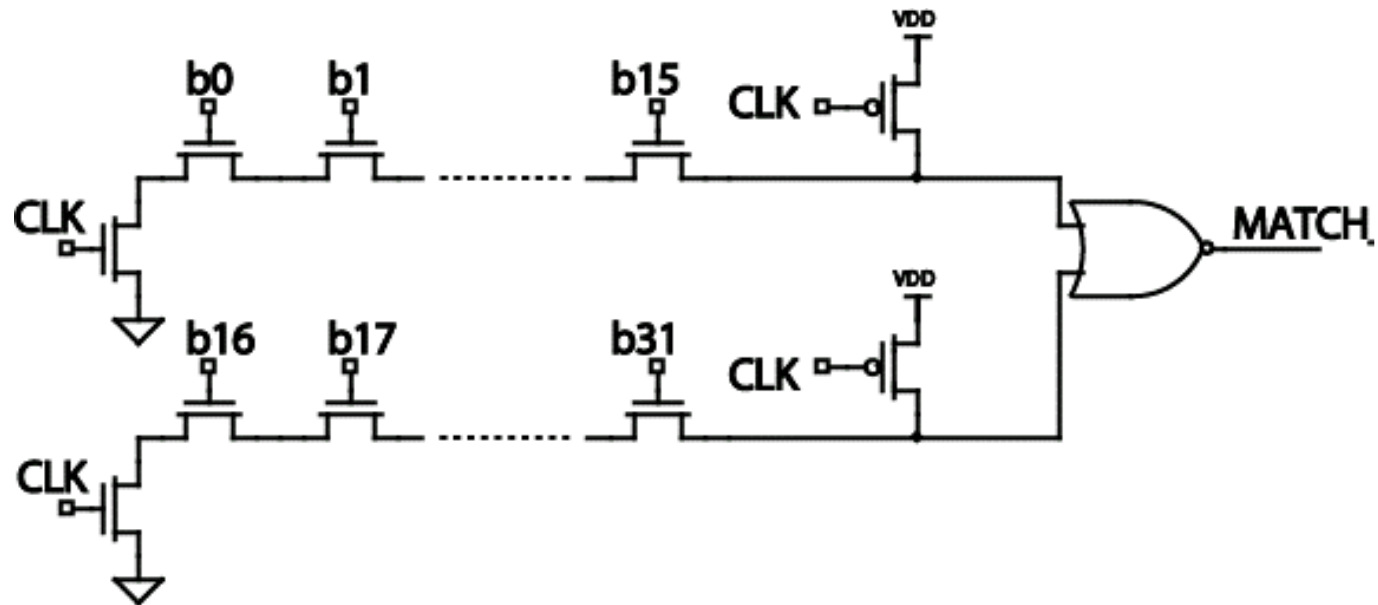
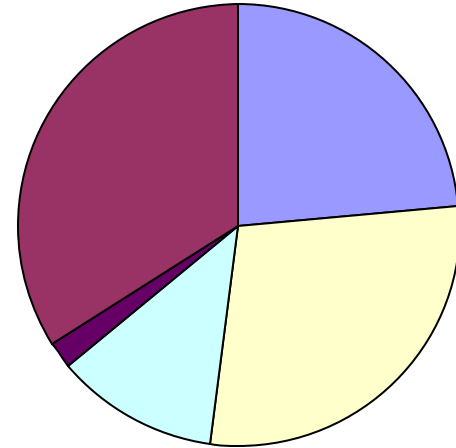
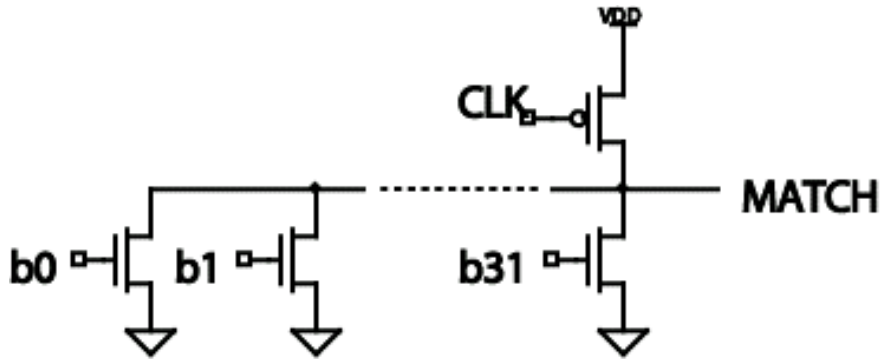

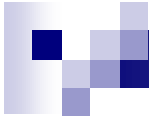

Energy Breakdown Summary

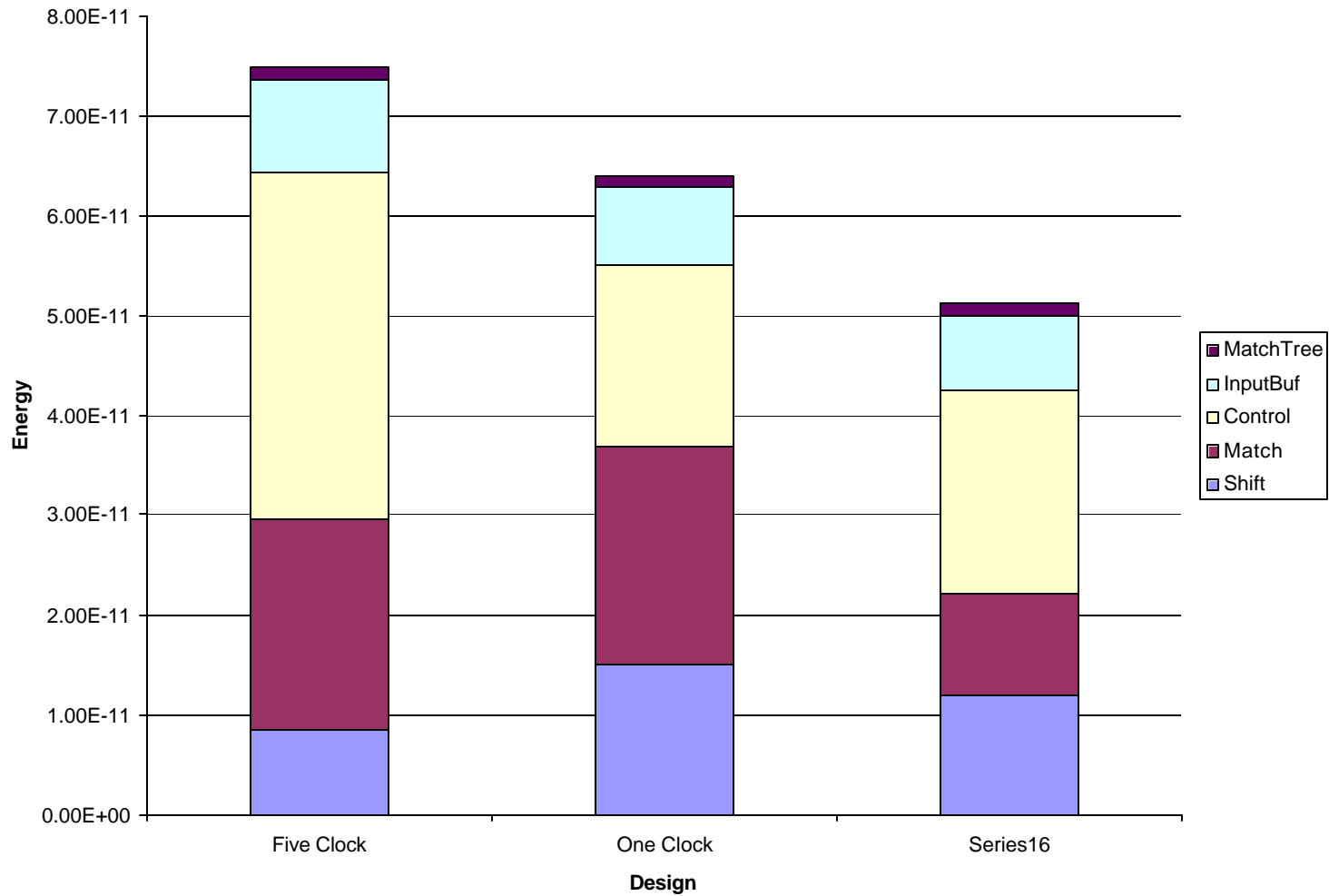

Obligatory Layout picture

- Probably not the most efficient layout but it passes DRC,LVS and is functional

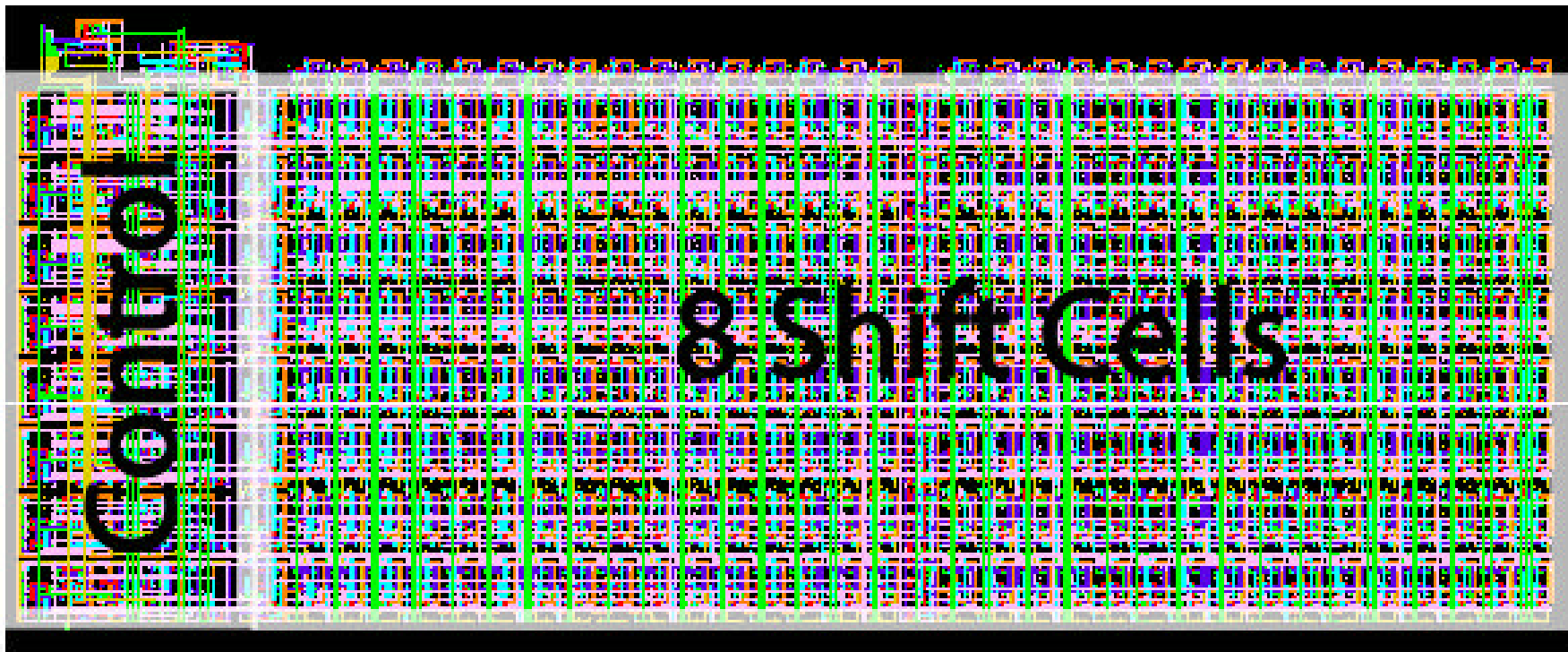



Oh Crap (Conclusion)

- On average our circuit will only start saving power with wires $>15\text{mm}$!
 - Wires this long on a die are rare
 - We need to encourage people to make bigger circuits (System on a Chip?)
- Trying to reduce wire power on die might have to wait until transistors consume less
 - But will leakage current then nullify our savings?