

A Device to Warn When Coolant is Low in a Car's Radiator

Besides a temperature gauge, the instrument panel of a car has an "Idiot Light" to warn when the motor is overheating. By the time the car's driver notices that light glowing, the motor has most likely suffered irreversible damage. The device described below is intended to blink the idiot light when the height of coolant in the radiator has fallen below its normal level but before this height falls so low as to jeopardize the motor. A blinking light may be noticed sooner than a steady glow. The device, built and installed in each of the writer's two 1984 Peugeot 505's over twenty years ago, has saved both cars from the premature self-destruction that befell many other 1984 505's.

How can Coolant get Lost?

Two kinds of leaks cause coolant loss. One kind is a leak in the radiator, in a flexible hose, in a gasket, or in a rubber seal in the motor's water pump or in the valve that controls the coolant's flow through the passenger compartment's heater. If severe enough, this kind of leak will drip a puddle of coolant under or into the car. Otherwise this kind of leak occurs only when hot coolant is pressurized by its expansion. The pressure, about 15 pounds per square inch, elevates the coolant's boiling point well above the 212° F. of water, thereby allowing the motor to run more efficiently, some as hot as 250° F. But the high pressure can open the leak, through which hot coolant then escapes as a vapor noticeable, if at all, only by its smell.

The second kind of leak is in a gasket between the motor's block and a cylinder head. This kind of leak can allow pressurized coolant to escape into the motor's lubricating oil, or high-pressure exhaust gas to escape into the coolant. Coolant that gets into the oil combines with it to form a glue that clogs oil passages and is difficult to clean out. Exhaust gas in the coolant accumulates in the cylinder head, driving coolant out through the radiator's overflow valve and causing the head to overheat for lack of coolant. This second kind of leak can cause severe damage quickly.

Coolant loss too often goes unnoticed until too late unless detected sooner by a warning device.

The Warning Device

It has two components. One is a Probe situated inside the radiator near enough to its top that the normal height of coolant barely covers the probe and carries a small electric current from it. If the coolant drops below the Probe, uncovering it, the electric current is interrupted, activating the second component of the device. This is a Blinker-Box whose electronic circuit closes a switch periodically to blink the idiot light that will otherwise glow steadily after the motor overheats.

While the light blinks, drive the car to a safe place and stop where the blinking's cause can be ascertained. There, if necessary, turn the motor off and let it cool enough that clean water can be added safely to the coolant, bringing its height above the probe, so the car can be driven to a nearby repair facility without damage to the motor. If no such facility is nearby the car will have to be towed to one.

Connections of Warning Device's Components

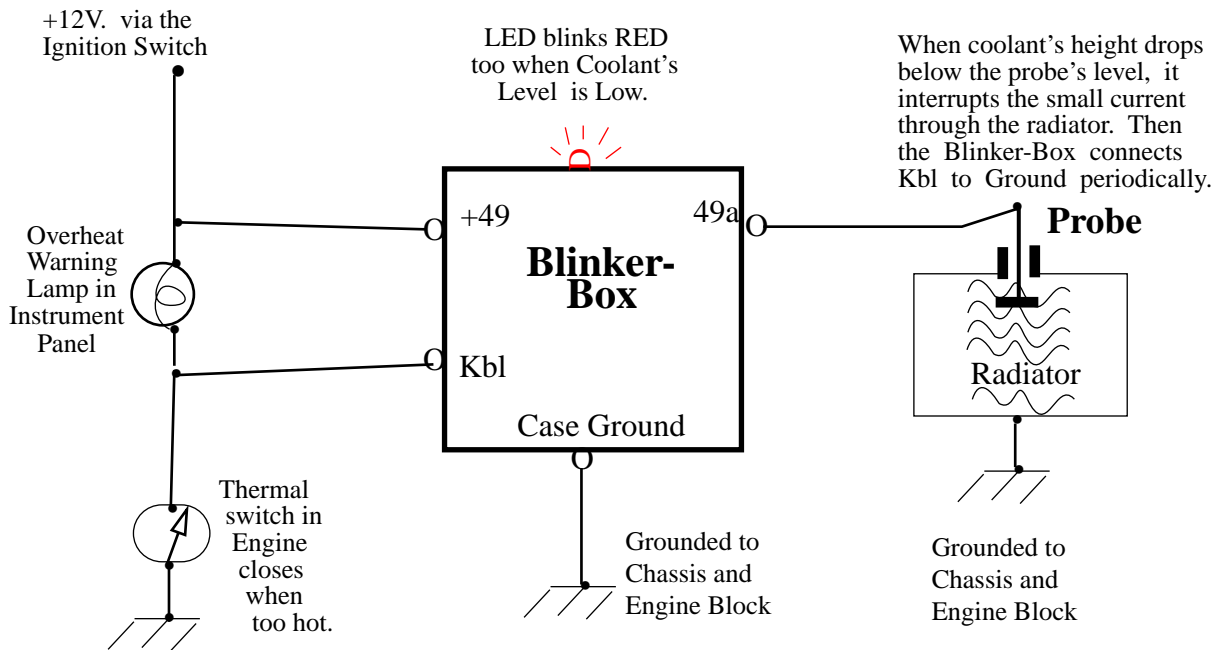

The engine's thermal switch closes when it gets too hot, thus turning on the warning lamp in the car's instrument panel. Before that can happen because of a loss of coolant, the Probe senses the coolant's lowered height in the radiator and signals the Blinker-Box to simulate a periodic closing of the thermal switch via the "Kbl" terminal, thus blinking the instrument panel's warning lamp.

The Probe

This part of the Warning Device poses a technical challenge: Pass an insulated stiff wire from outside to inside the radiator near enough to its top with no way for coolant to leak past the Probe.

I passed an insulated terminal through a hole drilled in the radiator's refill cap, and then soldered a male connector to the top of the terminal. To the bottom I soldered a short coil of brass wire ending in a horizontal stainless steel disk about the size of a quarter. The coil permitted the disk's depth to be adjusted: Too low would leave too little time between the blinking warning and the steady indication of overheating. Too high would occasionally allow transient air bubbles to set off a blinking false alarm that would detract from the warning device's credibility, reminiscent of *The Boy Who Cried "Wolf!"*. A suitable depth was found by trial and error. After this adjustment, the Probe works with no mechanical moving parts.

"No mechanical moving parts" has an advantage over other designs. Peugeot responded in 1985 to demands for a coolant-height sensor by introducing one to replace the radiator's fill cap. This sensor was a cartridge containing a floating magnet and a reed switch that closed when the magnet fell with a decline in coolant height. The closed switch lit up a panel light to warn that coolant was running low. But, according to mechanics who worked on Peugeots with these sensors, if tilted the floating magnets tended to get stuck either high or low.

The Blinker-Box

Instead of building them from scratch, I made them by altering turn-signal blinker-relays taken from junked 1970s Volkswagens. Below is the circuit for a Blinker-Box made from a modified HELLA blinker relay marked "Blink-Warnlicht-Relais 96/6-12V, 1-4 x 21W, VW 211953215A".

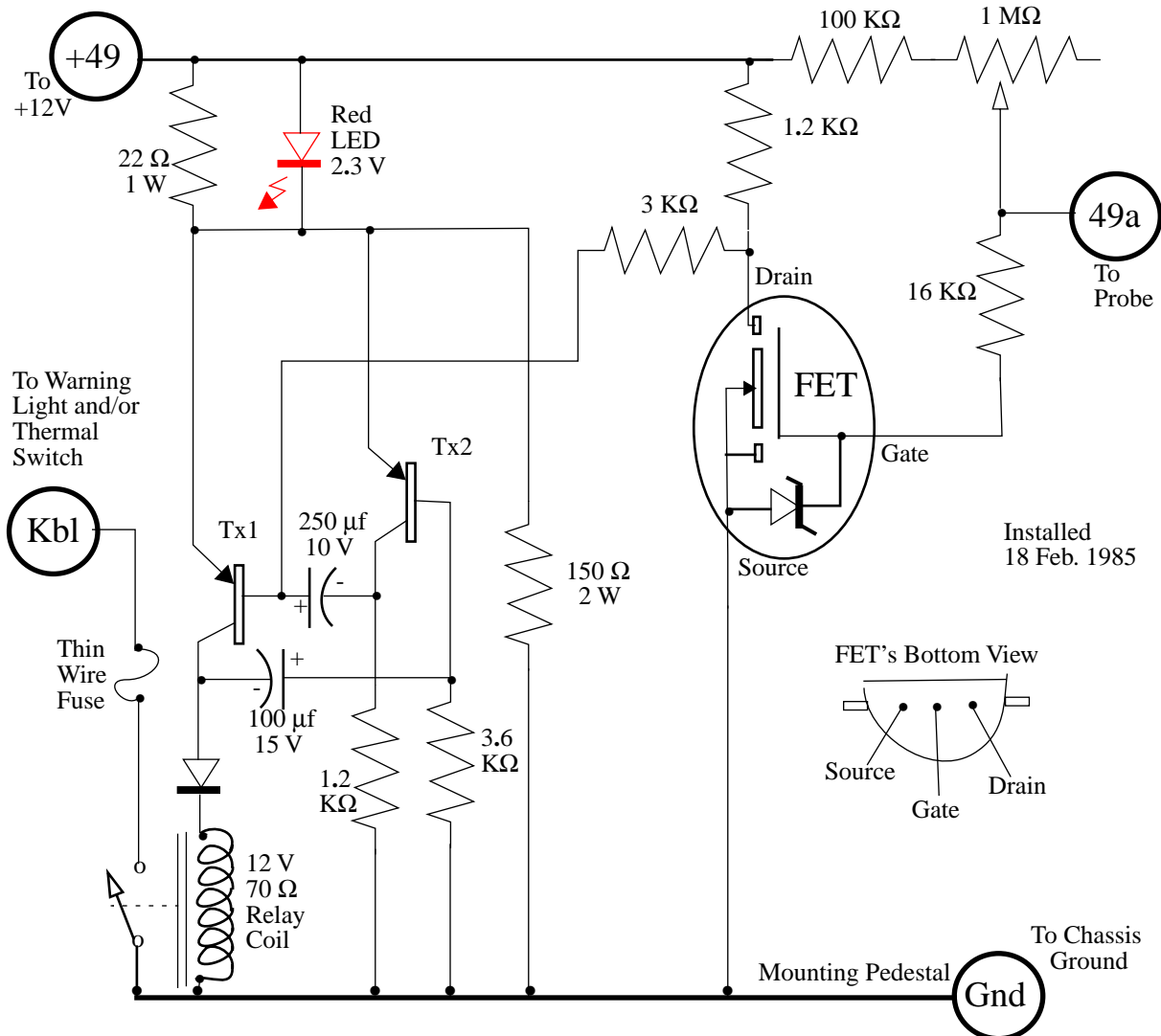

MOS Field-Effect Transistor FET is a VN 10 KM whose Gate Threshold is about $2V \pm 1V$. Tx1 and Tx2 are bipolar Germanium PNP Transistors capable of switching 250 ma. The red LED pokes through a tight hole drilled in the Blinker-Box's case.

Here is how the Blinker-Box works:

Normally the Probe is immersed in the coolant, which conducts terminal 49a to near Ground voltage, thereby turning off the FET and consequently also Tx1, whose base is pulled up to 12 V. through the 3 K Ω and 1.2 K Ω resistors. Meanwhile the 3.6 K Ω resistor pulls down the base of Tx2, turning it on. Its current plus that of the 150 Ω resistor draw less than about 90 ma. through the 22 Ω resistor, thus developing a voltage insufficient to turn the LED on. The relay is off too, so no current passes through terminal Kbl from the warning light; it is dark.

When enough coolant is lost to leave the Probe uncovered, only some tiny stray leakage current gets out through terminal 49a, and the 1 MΩ resistor has been adjusted to compensate for this leakage and bring the FET's gate voltage above 4V. This turns the FET on and brings its drain voltage near ground, drawing current from Tx1's base through the 3 KΩ resistor. This turns on Tx1 and the relay, which turns on the warning light through terminal Kbl. At the same time, enough current is drawn through the 22 Ω resistor to turn on the LED, but the 100 μf capacitor pushes up the base of Tx2, turning it off. After a fraction of a second the 100 μf capacitor discharges enough through the 3.6 KΩ resistor to let Tx2 turn on again. This, through the 250 μf capacitor, pushes up the base of Tx1 and promptly turns it off along with the relay, the warning light, and the LED. After a fraction of a second the 250 μf capacitor discharges enough through the 3 KΩ resistor to turn Tx1 on again, and the blinking repeats.

The thin-wire fuse helps to prevent a wiring mistake from starting a fire.

=====

Epilog

Ideally, every liquid-cooled motor should come with a probe installed at the highest point of the cooling system to warn of coolant loss before irreversible consequences ensue. The probe costs little, and can signal nowadays to one of a car's ubiquitous computers instead of a dedicated blinker-box. Ideally the motor's lubricant should be monitored by a probe too, but clean oil conducts no electricity at all so the oil probe has to be more complicated,— thermal or acoustic. Micro-Electronic manufacture of such probes has brought their cost low enough if produced in sufficient numbers.